

# Table of Contents - NFWB Sept. 25, 2023 Agenda Packet

1) September 25, 2023 NFWB Meeting Agenda .....	2
2) 2023 Budgeted Expenses - Expenditures of User Rates, Fees, and Charges Less Debt Service .....	7
3) Update on Executive Director Recruitment .....	8
4) Draft July 24, 2023 NFWB Meeting Minutes .....	9
5) Draft August 10, 2023 NFWB Special Meeting Minutes .....	17
6) WTP Roof Change Order Documents .....	21
7) Beech Avenue Project Photographs .....	28
8) Sedimentation Basin 3 Concrete Work Photographs .....	30
9) September 25, 2023 Personnel Actions .....	31
10) RESOLUTION 2023-09-001 - AWARD BID FOR 16 INCH CONCRETE WATER MAIN REPAIR AT HIGHLAND AND COLLEGE AVENUES .....	32
11) Bid Tabulation and Award Recommendation for 16 Inch PCCP Water Main Repair at Highland and College Avenues .....	34
12) RESOLUTION 2023-09-002 - PROCUREMENT OF WATER METERS .....	36
13) 2023-09-11 - Ti Sales Quotation for Water Meters .....	37
14) 2022-09-27 - Ti Sales Distributor Sole Source Letter .....	38
15) RESOLUTION 2023-09-003 - LABOR FOR INSTALLATION OF FIRE ALARMS .....	39
16) 2023-08-14 - Johnson Controls Quote for Labor to Wire Fire Alarms .....	41
17) RESOLUTION 2023-09-004 - AWARD OF BID FOR WATER AND SEWER CONSTRUCTION AND REPAIR MATERIALS .....	55
18) Water and Sewer Construction and Repair Materials Award Recommendation Letter .....	58
19) Water and Sewer Repair Materials Bid Tally Sheet Set 1 .....	61
20) Water and Sewer Repair Materials Bid Tally Sheet Set 2 .....	81
21) RESOLUTION 2023-09-005 - INSTALLATION OF ADDITIONAL CHLORINE GAS DETECTORS AT WATER TREATMENT PLANT .....	101
22) 2023-08-14 - Ferguson Electric Proposal FE002792, Chlorine Detector Installation .....	103
23) RESOLUTION 2023-09-006 - RENEWAL OF PROPERTY, LIABILITY, AND UMBRELLA INSURANCE POLICIES .....	104
24) 2023-09-21 - Wroblewski to Costello - Insurance Proposal .....	106
25) 2023-09-20 - USI Insurance Proposal .....	108
26) RESOLUTION 2023-09-007 - ACCEPTING PROPOSAL FOR 2023 AUDIT SERVICES .....	135
27) EFPR Proposal - 2023 Audit Services RFP .....	137
28) RESOLUTION 2023-09-008 - SETTLE CLAIM BY WINDSTREAM COMMUNICATIONS .....	191
29) RESOLUTION 2023-09-009 - AWARD BID FOR 42 INCH BUTTERFLY VALVE FOR WWTP INTERMEDIATE PUMP .....	193
30) 2023-09-21 - Butterfly Valve Award Recommendation Memorandum .....	194
31) 2023-09-21 - Butterfly Valve Bid Tabulation .....	195



## **AGENDA**

### **Business Meeting of the Niagara Falls Water Board September 25, 2023 at 5:00 p.m.**

**Water Treatment Plant Conference Room  
5815 Buffalo Avenue, Niagara Falls New York 14304**

**Meeting may be attended in person  
or via videoconference – visit NFWB.org for details.**

#### **1. Preliminary Matters**

##### **a. Attendance:**

**Asklar (Board Member/Chairman of Finance/Member Exec. Staff Review Cmte.)**

**Forster (Chairman)**

**Kimble (Board Member)**

**Larkin (Board Member/Vice Chairwoman/Governance Chairwoman/  
Chairwoman Exec. Staff Review Cmte.)**

**Leffler (Board Member/Member Exec. Staff Review Cmte.)**

**b. Public Comments (All speakers must register with the meeting clerk prior to roll call and are limited to three minutes per person – total time for all speakers may not exceed one hour).**

**c. Comments from Chairman Forster**

**i. 2023 Budgeted Expenses - Expenditures of User Rates, Fees, and  
Charges Less Debt Service**

**ii. Update on Executive Director Recruitment**

**d. Presentations (none scheduled)**

- e. **Letters and Communications**
  - i. **2023-09-14 – COVID Wastewater Surveillance Update Memorandum**
- f. **Prior Meeting Minutes**
  - i. **Draft July 24, 2023 Meeting Minutes**
  - ii. **Draft August 10, 2023 Special Meeting Minutes**
- 2. **Acting Executive Director – Michael Eagler**
  - a. **WWTP Project Budget Tracker (CPL)**
  - b. **WWTP Construction Schedule Tracker (CPL)**
  - c. **Financial Award Summary (CPL)**
  - d. **WTP Roof Replacement Bid Change Order Documents**
  - e. **Beech Avenue Project Photographs**
  - f. **Sedimentation Basin 3 Concrete Work Photographs**
- 3. **Inside Infrastructure and Operations – Russell DeFranco**
- 4. **Outside Infrastructure Updates – Cortez Bradberry**
- 5. **Engineering – Douglas Williamson**
- 6. **Personnel Items – David San Lorenzo**
  - a. **September 25, 2023 Personnel Actions**
  - b. **Union Time Off Year to Date**
- 7. **Information Technology (IT) –Jonathan Joyce**

**8. Finance – Brian Majchrowicz**

- a. **2024 Budget Update**
- b. **Credit Card Payments**
- c. **Revenue Budget Performance Report through 8/31/2023**
- d. **Sewer Fund Expense Budget Performance Report through 8/31/2023**
- c. **Water Fund Expense Budget Performance Report through 8/31/2023**
- d. **Board Fund Expense Budget Performance Report through 8/31/2023**
- e. **Key Bank and Bank on Buffalo Balance Report**
- f. **Wilmington Trust Balance Report**
- g. **Treasury Account Balance Report**
- h. **Budget Amendments Report**
- i. **Capital Payments**
  - 1. **July 2023**
  - 2. **August 2023**

**9. Questions Regarding August 2023 Operations and Maintenance Report**

**10. Safety – John Accardo**

**11. General Counsel and Secretary – Sean Costello**

**12. From the Chairman**

**13. Resolutions**

**2023-09-001 – AWARD BID FOR 16 INCH CONCRETE WATER MAIN REPAIR AT HIGHLAND AND COLLEGE AVENUES**

- a. **Bid Tabulation and Award Recommendation for 16 Inch PCCP Water Main Repair at Highland and College Avenues**

**2023-09-002 – PROCUREMENT OF WATER METERS**

- a. **2023-09-11 - Ti Sales Quotation for Water Meters**
- b. **2022-09-27 - Ti Sales Distributor Sole Source Letter**

**2023-09-003 - LABOR FOR INSTALLATION OF FIRE ALARMS**

- a. **2022-09-27 - Ti Sales Distributor Sole Source Letter**

**2023-09-004 – AWARD OF BID FOR WATER AND SEWER CONSTRUCTION AND REPAIR MATERIALS**

- a. **Water and Sewer Construction and Repair Materials Award Recommendation Letter**
- b. **Water and Sewer Repair Materials Bid Tally Sheet Set 1**
- c. **Water and Sewer Repair Materials Bid Tally Sheet Set 2**

**2023-09-005 – INSTALLATION OF ADDITIONAL CHLORINE GAS DETECTORS AT WATER TREATMENT PLANT**

- a. **2023-08-14 - Ferguson Electric Proposal FE002792, Chlorine Detector Installation**

**2023-09-006 – RENEWAL OF PROPERTY, LIABILITY, AND UMBRELLA INSURANCE POLICIES**

- a. **2023-09-21 - Wroblewski to Costello - Insurance Proposal**
- b. **2023-09-20 - USI Insurance Proposal**

**2023-09-007 – ACCEPTING PROPOSAL FOR 2023 AUDIT SERVICES**

- a. **EFPR 2023 Audit RFP Response**

**2023-09-008 – SETTLE CLAIM BY WINDSTREAM COMMUNICATIONS**

**2023-09-009 – AWARD BID FOR 42-INCH BUTTERFLY VALVE FOR WWTP INTERMEDIATE PUMP**

- a. **2023-09-21 - Butterfly Valve Award Recommendation Memorandum**
- b. **2023-09-21 - Butterfly Valve Bid Tabulation**

**14. Unfinished/Old Business**

**1) WWTP Sodium Hypochlorite Tank Replacement**

- 7/14/22: The 2021 WIIA Sewer (WWTP) Grant of \$1,125,000 was awarded on April 19, 2022 that included the some of the funds necessary to complete the WWTP tank removal and replacement work. We may be able to utilize some of the remaining balance of the WWTP Phase II grant to assist with this work, as well. We need approval from the NYSDEC to include some of the WWTP tank replacement work under this WWTP Phase II grant. The draft WWTP Tank Replacement RFP that was created needs to be finalized to show the grant funding sources that have been approved for the project, before we can proceed.
- 7/14/23: Resolution for engineering services in work session packet.
- 9/15/23: Contract amendment for work needs to be prepared.

## **2) WTP Perimeter Fence Replacement Update**

- 7/14/22: The 2021 WIIA Water Grant application of \$3 million was awarded on April 19, 2022 that included some funds that can be used for the WTP perimeter fence replacement work. On 7/13/22, the capital purchase order for the \$8,000 brush hog was completed to assist with the work in-house. WTP maintenance to schedule and coordinate the fencing work.
- 7/14/23: Security gate and lower fence for clear well building scheduled for week of July 17.
- 9/15/23: Stone removed from WTP roof is being placed along fence perimeter to close off gaps. Temporary repairs made to deteriorated section of fence. Quote obtained from Fox Fence for replacement of deteriorated section of fence.

## **15. New Business & Additional Items for Discussion**

**16. Executive Session: Anticipated motion to enter into executive session for the purpose of considering matters leading to the appointment, employment, promotion, demotion, or removal of a particular person (Public Officers Law § 105(f)).**

## **17. Adjournment of Meeting**

## 2023 BUDGETED EXPENSES-EXPENDITURES OF USER RATES, FEES & CHARGES LESS DEBT SERVICE

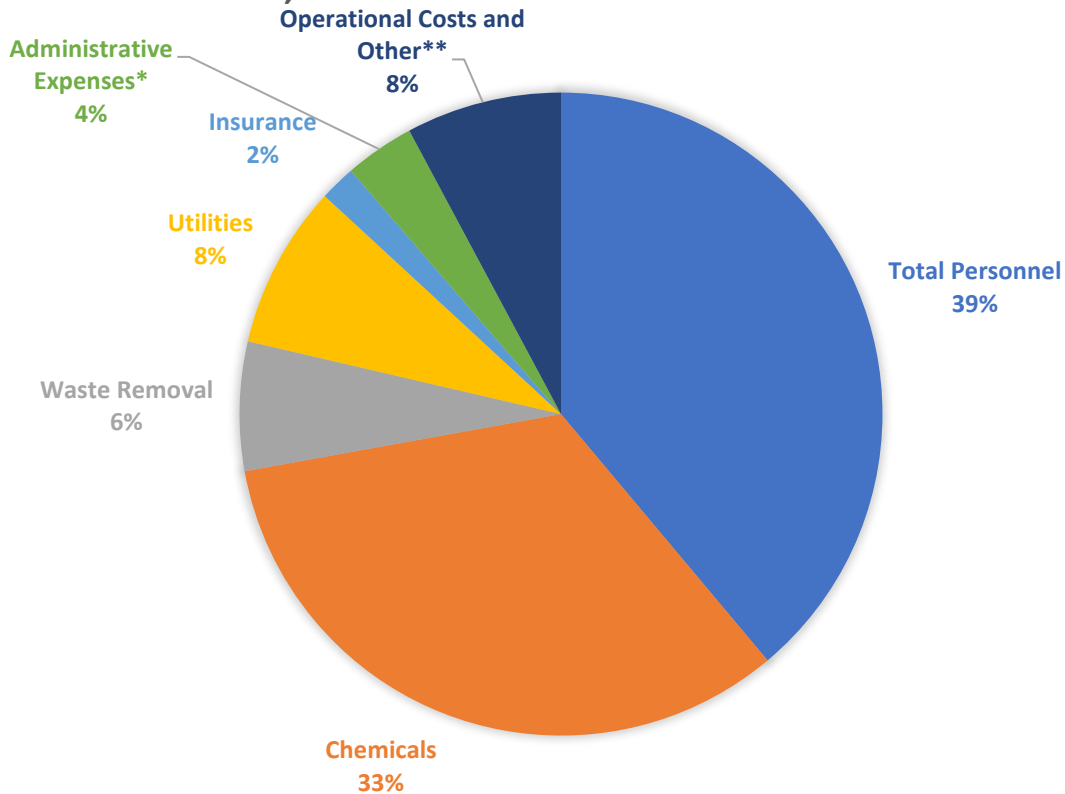

	<u>2023</u>	<u>Percentage of Total</u>
-	-	
Total Personnel	\$ 12,599,986	39%
Chemicals	\$ 10,775,000	33%
Waste Removal	\$ 2,100,500	6%
Utilities	\$ 2,664,500	8%
Insurance	\$ 585,000	2%
Administrative Expenses*	\$ 1,137,191	4%
Operational Costs and Other**	<u>\$ 2,534,190</u>	<u>8%</u>
Total	<u>\$ 32,396,367</u>	<u>100%</u>

\* Includes Office Supplies, Training, Computer Services & Software, and Professional Services

\*\* Includes Rentals, Auto Expenses, Leases, Tools & Small Equipment, Machinery, Materials, and Undesignated Services



## **Update on Executive Director Recruitment September 25, 2023 NFWB Board Meeting**

### **❖ Opening Announced in the Following Sources:**

- Niagara Gazette
  - Ran two times;
- Buffalo News:
  - Sunday Print;
  - Print Job Finder Publication;
  - Online;
- Indeed.com;
- LinkedIn;
- ZipRecruiter;
- Industry/Trade Groups:
  - NY Section, AWWA (American Water Works Assn., a water industry group)
  - NY Water Environment Assn. (wastewater industry)
  - NY Rural Water Assn.

### **❖ 68 Applications Received.**

### **❖ 12 Candidates Selected for Further Review.**

### **❖ 9 Telephone Screening Interviews Conducted.**

### **❖ 3 In-Person Interviews Scheduled.**





## MINUTES

### **Business Meeting of the Niagara Falls Water Board July 24, 2023 at 5:00 p.m.**

**Water Treatment Plant Conference Room  
5815 Buffalo Avenue, Niagara Falls New York 14304**

**Meeting may be attended in person  
or via videoconference – visit NFWB.org for details.**

#### **1. Preliminary Matters**

*Chairman Forster called the meeting to order at 5:00 p.m.*

##### **a. Attendance:**

**Asklar (Board Member/Chairman of Finance/Member Exec. Staff Review Cmte.) Present**

**Forster (Chairman) Present**

**Kimble (Board Member) Present via Videoconference**

**Larkin (Board Member/Vice Chairwoman/Governance Chairwoman/  
Chairwoman Exec. Staff Review Cmte.) Present**

**Leffler (Board Member/Member Exec. Staff Review Cmte.) Present**

##### **b. Public Comments (All speakers must register with the meeting clerk prior to roll call and are limited to three minutes per person – total time for all speakers may not exceed one hour).**

*Jason Haywood of 906 Morley Ave spoke about a bill he received a bill for \$3,200 for the billing period of February-May 2023. He had a plumber check for leaks but did not find anything. He sent in an adjustment application. Chairman Forster stated Michael Eagler, Chief of Outside Infrastructure will follow up on the meter and Brian Majchrowicz, Director of Finance will follow up on the application.*

**c. Comments from Chairman Forster**

*Chairman Forster asked that the Board enter into executive session to discuss matters leading to the appointment, employment, promotion, demotion, or removal of a particular person.*

*Motion by Board Member Larkin and seconded by Board Member Leffler to enter into Executive Session at 5:03 p.m.*

*Asklar \_\_Y\_\_ Forster \_\_Y\_\_ Kimble \_\_Y\_\_ Larkin \_\_Y\_\_ Leffler \_\_Y\_\_*

*Motion carried, 5-0.*

*Motion by Board Member Asklar and seconded by Board Member Leffler to exit Executive Session at 6:23 p.m.*

*Asklar \_\_Y\_\_ Forster \_\_Y\_\_ Kimble \_\_Y\_\_ Larkin \_\_Y\_\_ Leffler \_\_Y\_\_*

*Motion carried, 5-0.*

**i. 2023 Budgeted Expenses - Expenditures of User Rates, Fees, and Charges Less Debt Service**

**d. Presentations (none scheduled)**

**e. Letters and Communications**

- i. 2023-07-11 – COVID Wastewater Surveillance Update Memorandum**
- ii. 2023-06-30 – 2022 Bipartisan Infrastructure Law Lead Service Line Replacement Grant Award**
- iii. 2023 Rain Barrel Sale Flyer**

*The 2023 Rain Barrel Sale Flyer is posted on [nfwb.org](http://nfwb.org) under “News.”*

**f. Prior Meeting Minutes**

**i. Draft June 26, 2023 Meeting Minutes**

*Motion by Board Member Kimble and seconded by Board Member Asklar to approve the June 26, 2023 meeting minutes.*

*Asklar \_\_Y\_\_ Forster \_\_Y\_\_ Kimble \_\_Y\_\_ Larkin \_\_Y\_\_ Leffler \_\_Y\_\_*

*Motion carried, 5-0.*

**2. Executive Director – Dr. Abderrahman Zehraoui**

- a. WWTP Project Budget Tracker (CPL)**
- b. WWTP Construction Schedule Tracker (CPL)**
- c. Financial Award Summary (CPL)**

**3. Inside Infrastructure and Operations – Russell DeFranco**

**4. Outside Infrastructure Updates – Michael Eagler**

*Mr. Eagler shared some cost savings numbers from projects completed in-house instead of contracting them out.*

*Hyde Park and Walnut: \$158,192 savings, after accounting for all materials, benefits, and overtime.*

*652 Elmwood Avenue: \$33,500 savings*

*25<sup>th</sup> Street: \$32,000 savings*

*Fairfield Avenue: \$12,000 savings*

*There is an upcoming job on Beech Ave expected to RFP at \$248,000, which will also be done in-house if possible.*

*The trees in front of the Water Treatment Plant have been trimmed, and brush hogging along the fence line is complete.*

**5. Engineering – Douglas Williamson**

*There will be an inspection for Ferric Chloride Tanks 214 and 215 in the next few weeks, which will determine if they can be repaired.*

*Mr. Williamson sent an application to the DEC for Tank 213, sulfuric acid, to remove it from the active list and now no longer needs to be inspected.*

*An email was received today from the EPA stating NFWB satisfactorily addressed the issues raised by the Pretreatment Compliance Inspection.*

**6. Personnel Items – David San Lorenzo**

**a. July 24, 2023 Personnel Actions**

*Chairman Forster asked the Board to make an amendment to the July 24, 2023 Personnel Action Sheet, to add an increase in the salary of David San Lorenzo, Director of Administrative Services, by 4 %, effective retroactively July 1<sup>st</sup>.*

*Motion by Board Member Larkin and seconded by Board Member Leffler to amend the Personnel Action Sheet.*

*Asklar \_\_Y\_\_ Forster \_\_Y\_\_ Kimble \_\_Y\_\_ Larkin \_\_Y\_\_ Leffler \_\_Y\_\_*

*Motion carried, 5-0.*

*Motion by Board Member Larkin and seconded by Board Member Kimble to approve the July 24, 2023 Personnel Actions.*

*Asklar \_\_Y\_\_ Forster \_\_Y\_\_ Kimble \_\_Y\_\_ Larkin \_\_Y\_\_ Leffler \_\_Y\_\_*

*Motion carried, 5-0*

**b. Union Time Off Year to Date**

**7. Information Technology (IT) – Dr. Abderrahman Zehraoui and Jonathan Joyce**

**a. Cybersecurity Updates**

*Mr. San Lorenzo stated IT met with a printer vendor and will have pricing and a plan for universal printers by the next board meeting.*

**8. Finance – Brian Majchrowicz**

- a. Revenue Budget Performance Report through 6/30/2023**
- b. Sewer Fund Expense Budget Performance Report through 6/30/2023**
- c. Water Fund Expense Budget Performance Report through 6/30/2023**
- d. Board Fund Expense Budget Performance Report through 6/30/2023**
- e. Key Bank and Bank on Buffalo Balance Report**
- f. Wilmington Trust Balance Report**
- g. Treasury Account Balance Report**
- h. Budget Amendments Report**
- i. Capital Payments**

**9. Questions Regarding June 2023 Operations and Maintenance Report**

**10. Safety – John Accardo**

*Two vehicles were de-fleeted today, which will save \$843 a month and \$2,200 in insurance, and will net at about \$48,000.*

*August 8, 2023 will be the first meeting of the reinstated Safety Committee, which will meet once a month.*

**11. General Counsel and Secretary – Sean Costello**

**12. From the Chairman**

*Efforts continue to obtain \$250 million in funds for WWTP plant conversion. The state has moved the application deadline to August 11<sup>th</sup>, and there will need to be a special meeting in August called to vote on a resolution to apply for funding.*

**13. Resolutions**

**2023-07-001 - RENEWAL OF PERMA WORKERS COMPENSATION POLICY**

**a. Workers Compensation Renewal Proposal**

*Motion by Board Member Asklar and seconded by Board Member Larkin to approve.*

*Asklar \_\_Y\_\_ Forster \_\_Y\_\_ Kimble \_\_Y\_\_ Larkin \_\_Y\_\_ Leffler \_\_Y\_\_*

*Motion carried, 5-0.*

**2023-07-002 - AUTHORIZATION TO PROCEED WITH NYPA CLEAN ENERGY SERVICES PROJECT**

- a. 2023-05-22 - NYPA Proposed Authorization to Proceed for Services Related to Solar Development at Water Treatment Plant**
- b. 2023-05-22 - NYPA Summary of Plan to Provide Advisory Services for Solar Development at WTP**

*Motion by Board Member Larkin and seconded by Board Member Leffler to approve.*

*Asklar \_\_abstain\_\_ Forster \_\_Y\_\_ Kimble \_\_Y\_\_ Larkin \_\_Y\_\_ Leffler \_\_Y\_\_*

*Motion carried, 4-0.*

**2023-07-003 - PROCUREMENT OF WATER MAIN VALVES AND HYMAX CLAMPS**  
a. **2023-05-31 - Core and Main Quote for Water Main Valves and Hymax Clamps**

*Motion by Board Member Larkin and seconded by Board Member Kimble to approve.*

*Asklar \_\_Y\_\_ Forster \_\_Y\_\_ Kimble \_\_Y\_\_ Larkin \_\_Y\_\_ Leffler \_\_Y\_\_*

*Motion carried, 5-0.*

**2023-07-004 - MILTON CAT CHANGE ORDER FOR WATER TREATMENT PLANT GENERATOR CONTROL UPGRADE PROJECT**  
a. **2023-07-11 - Milton CAT Change Order for Generator Control Upgrade Project**

*Motion by Board Member Leffler and seconded by Board Member Larkin to approve.*

*Asklar \_\_Y\_\_ Forster \_\_Y\_\_ Kimble \_\_Y\_\_ Larkin \_\_Y\_\_ Leffler \_\_Y\_\_*

*Motion carried, 5-0.*

**2023-07-005 - CHANGE ORDER FOR PROJECT 6 ENGINEERING SERVICES AGREEMENT, SODIUM HYPOCHLORITE TANK, SECONDARY CONTAINMENT, PUMPING, PIPING, AND CONTROLS**  
a. **2023-06-28 - AECOM Proposal - Change Order to WWTP Project 6 Agreement to Perform Engineering Services for Sodium Hypochlorite Tank Replacement, Pump Addition**

*Motion by Board Member Asklar and seconded by Board Member Larkin to approve.*

*Asklar \_\_Y\_\_ Forster \_\_Y\_\_ Kimble \_\_Y\_\_ Larkin \_\_Y\_\_ Leffler \_\_Y\_\_*

*Motion carried, 5-0.*

**2023-07-006 - AWARD BID FOR WATER TREATMENT PLANT ROOF REPLACEMENT**

- a. **2023-07-17 - CPL WTP Roof Bid Award Recommendation and Bid Tabulation**
- b. **Diagram of WTP Roof Sections Used in Bid**

*Motion by Board Member Kimble and seconded by Board Member Asklar to approve.*

*Asklar \_\_Y\_\_ Forster \_\_Y\_\_ Kimble \_\_Y\_\_ Larkin \_\_Y\_\_ Leffler \_\_Y\_\_*

*Motion carried, 5-0.*

**2023-07-007 - WTP SECURITY UPGRADES – DOOR ACCESS CONTROL CARD READER SYSTEM AND INSTALLATION OF TWO DOORS FOR ACCESS CONTROL**

**a. 2023-06-16 - Jens Glass Estimate for WTP Security Upgrades**

*Motion by Board Member Asklar and seconded by Board Member Kimble to approve.*

*Asklar \_\_Y\_\_ Forster \_\_Y\_\_ Kimble \_\_Y\_\_ Larkin \_\_Y\_\_ Leffler \_\_Y\_\_*

*Motion carried, 5-0.*

**14. Unfinished/Old Business**

**1) WWTP Sodium Hypochlorite Tank Replacement**

- 7/14/22: The 2021 WIIA Sewer (WWTP) Grant of \$1,125,000 was awarded on April 19, 2022 that included the some of the funds necessary to complete the WWTP tank removal and replacement work. We may be able to utilize some of the remaining balance of the WWTP Phase II grant to assist with this work, as well. We need approval from the NYSDEC to include some of the WWTP tank replacement work under this WWTP Phase II grant. The draft WWTP Tank Replacement RFP that was created needs to be finalized to show the grant funding sources that have been approved for the project, before we can proceed.
- 7/14/23: Resolution for engineering services in work session packet.

**2) WTP Perimeter Fence Replacement Update**

- 7/14/22: The 2021 WIIA Water Grant application of \$3 million was awarded on April 19, 2022 that included some funds that can be used for the WTP perimeter fence replacement work. On 7/13/22, the capital purchase order for the \$8,000 brush hog was completed to assist with the work in-house. WTP maintenance to schedule and coordinate the fencing work.
- 7/14/23: Security gate and lower fence for clear well building scheduled for week of July 17.

*Davidson Fence came today to repair one section of the fence. Mr. DeFranco is working with Mr. Eagler to fill in low, wet, and weedy areas.*

**15. New Business & Additional Items for Discussion**

- a. Schedule a Special Meeting for Grant Applications and Change Order for WWTP Project 1 – Scope of Masonry Repair Work Required in Basin 3 Greater Than Anticipated**

**16. Executive Session: Anticipated motion to enter into executive session for the purpose of considering matters leading to the appointment, employment, promotion, demotion, or removal of a particular person (Public Officers Law § 105(f)).**

*Conducted earlier in the meeting.*

**17. Adjournment of Meeting**

*Motion by Board Member Asklar and seconded by Board Member Larkin to adjourn the meeting at 6:45 p.m.*

*Asklar \_\_Y\_\_ Forster \_\_Y\_\_ Kimble \_\_Y\_\_ Larkin \_\_Y\_\_ Leffler \_\_Y\_\_*

*Motion carried, 5-0.*





## MINUTES

### Special Meeting of the Niagara Falls Water Board August 10, 2023 at 5:00 p.m.

Water Treatment Plant Conference Room  
5815 Buffalo Avenue, Niagara Falls, New York 14304

*Chairman Forster called the meeting to order at 5:00 p.m.*

#### 1. Attendance:

Asklar (Board Member/Chairman of Finance/Member Exec. Staff Review Cmte.) *Present*

Forster (Chairman) *Present*

Kimble (Board Member) *Present via Videoconference*

Larkin (Board Member/Vice Chairwoman/Governance Chairwoman/  
Chairwoman Exec. Staff Review Cmte.) *Present*

Leffler (Board Member/Member Exec. Staff Review Cmte.) *Present*

*Chairman Forster asked that the Board enter into executive session to discuss matters leading to the appointment, employment, promotion, demotion, or removal of a particular person.*

*Motion by Board Member Larkin and seconded by Board Member Leffler to enter into Executive Session at 5:03 p.m.*

*Asklar \_\_Y\_\_ Forster \_\_Y\_\_ Kimble \_\_Y\_\_ Larkin \_\_Y\_\_ Leffler \_\_Y\_\_*

*Motion carried, 5-0.*

*Motion by Board Member Asklar and seconded by Board Member Leffler to exit Executive Session at 5:19 p.m.*

*Asklar \_\_Y\_\_ Forster \_\_Y\_\_ Kimble \_\_Y\_\_ Larkin \_\_Y\_\_ Leffler \_\_Y\_\_*

*Motion carried, 5-0.*

**2. Letters and Communications**

- a. 2023-08-08 – Zehraoui to Forster, Resignation Effective September 8, 2023
- b. 2023-08-07 – DEC Correspondence – Notice of Intent to Modify and Renew WWTP SPDES Permit

*Mr. Costello stated the above draft permit is still being analyzed, but will likely require challenging and costly improvements, including installation of dechlorination equipment and BOD removal. The Water Board will respond to DEC stating all concerns.*

**3. Resolutions**

**2023-08-001 - PROJECT 1 CHANGE ORDER FOR CONCRETE REPAIR WORK**

- a. Hohl Change Order for WWTP Project 1 Additional Concrete Repair

*Jay Meyers from CPL commented on insufficient grating and lack of steps in Basin 5, stating it was likely a design flaw. He also commented on concrete repair, stating the amount of work needed when the project was designed 6 years ago was underestimated.*

*Motion by Board Member Larkin and seconded by Board Member Leffler to approve.*

*Asklar \_\_Y\_\_ Forster \_\_Y\_\_ Kimble \_\_Y\_\_ Larkin \_\_Y\_\_ Leffler \_\_Y\_\_*

*Motion carried, 5-0.*

**2023-08-002 - SETTLE PAVAN CLAIM**

- a. Notice of Claim – Pavan (Redacted)

*Motion by Board Member Larkin and seconded by Board Member Kimble to approve.*

*Asklar \_\_Y\_\_ Forster \_\_Y\_\_ Kimble \_\_Y\_\_ Larkin \_\_Y\_\_ Leffler \_\_Y\_\_*

*Motion carried, 5-0.*

**2023-08-003 - SEQR REVIEW FOR WWTP BIOLOGICAL CONVERSION PROJECT**

**a. WWTP Conversion - Short Environmental Assessment Form Part 1**

**i. WWTP Conversion - Narrative Addendum to Short Environmental Assessment Form Part 1**

**b. WWTP Conversion - Short Environmental Assessment Form Parts 2 and 3**

*Motion by Board Member Asklar and seconded by Board Member Leffler to approve.*

*Asklar \_\_Y\_\_ Forster \_\_Y\_\_ Kimble \_\_Y\_\_ Larkin \_\_Y\_\_ Leffler \_\_Y\_\_*

*Motion carried, 5-0.*

**2023-08-004 - APPLICATION FOR WIIA, BIL, AND WQIP FUNDING FOR WASTEWATER TREATMENT PLANT CONVERSION WORK**

*Motion by Board Member Leffler and seconded by Board Member Asklar to approve.*

*Asklar \_\_Y\_\_ Forster \_\_Y\_\_ Kimble \_\_Y\_\_ Larkin \_\_Y\_\_ Leffler \_\_Y\_\_*

*Motion carried, 5-0.*

**2023-08-005 - WIIA GRANT APPLICATION AND SEQR REVIEW FOR CALUMET AVE. SEWER REHABILITATION**

*Motion by Board Member Kimble and seconded by Board Member Larkin to approve.*

*Asklar \_\_Y\_\_ Forster \_\_Y\_\_ Kimble \_\_Y\_\_ Larkin \_\_Y\_\_ Leffler \_\_Y\_\_*

*Motion carried, 5-0.*

**2023-08-006 - WIIA GRANT APPLICATION AND SEQR REVIEW FOR WATER SYSTEM IMPROVEMENTS**

*Motion by Board Member Larkin and seconded by Board Member Kimble to approve.*

*Asklar \_\_Y\_\_ Forster \_\_Y\_\_ Kimble \_\_Y\_\_ Larkin \_\_Y\_\_ Leffler \_\_Y\_\_*

*Motion carried, 5-0.*

4. **Executive Session:** Anticipated motion to enter into executive session for the purpose of considering matters leading to the appointment, employment, promotion, demotion, or removal of a particular person (Public Officers Law § 105(f)).

*Conducted earlier in meeting.*

5. **Adjournment of Meeting**

*Motion by Board Member Asklar and seconded by Board Member Larkin to adjourn the meeting at 5:35 p.m.*

*Asklar \_\_Y\_\_ Forster \_\_Y\_\_ Kimble \_\_Y\_\_ Larkin \_\_Y\_\_ Leffler \_\_Y\_\_*

*Motion carried, 5-0.*



# AIA Document G701® – 2017

## Change Order

<b>PROJECT:</b> <i>(Name and address)</i> Water Treatment Plant Roof Reconstruction 5815 Buffalo Ave. Niagara Falls, NY 14304	<b>CONTRACT INFORMATION:</b> Contract For: General Construction  Date: 09/21/2023	<b>CHANGE ORDER INFORMATION:</b> Change Order Number: 001  Date: 09/21/23
<b>OWNER:</b> <i>(Name and address)</i> Niagara Falls Water Board 5815 Buffalo Ave. Niagara Falls, NY 14304	<b>ARCHITECT:</b> <i>(Name and address)</i> CPL 26 Mississippi St. Buffalo, NY 14203	<b>CONTRACTOR:</b> <i>(Name and address)</i> Weaver Metal & Roofing, Inc. 40 Appenheimer Ave. Buffalo, NY 14214

**THE CONTRACT IS CHANGED AS FOLLOWS:**

*(Insert a detailed description of the change and, if applicable, attach or reference specific exhibits. Also include agreed upon adjustments attributable to executed Construction Change Directives.)*

Existing substrate at top and interior face of wall is not suitable to install EPDM flashings direct, need to install plywood to provide suitable substrate, to minimize costs, modify detail to eliminate coping and install Carlisle SureTite Cleat with shop fabricated 050 aluminum fascia cover. The change will not effect the Carlisle Total System Warranty, the original warranty as specified will apply.

The original Contract Sum was	\$ 3,362,000.00
The net change by previously authorized Change Orders	\$ 0.00
The Contract Sum prior to this Change Order was	\$ 3,362,000.00
The Contract Sum will be decreased by this Change Order in the amount of	\$ 15,497.00
The new Contract Sum including this Change Order will be	\$ 3,346,503.00

The Contract Time will be unchanged by Zero (0) days.

The new date of Substantial Completion will be

**NOTE:** This Change Order does not include adjustments to the Contract Sum or Guaranteed Maximum Price, or the Contract Time, that have been authorized by Construction Change Directive until the cost and time have been agreed upon by both the Owner and Contractor, in which case a Change Order is executed to supersede the Construction Change Directive.

**NOT VALID UNTIL SIGNED BY THE ARCHITECT, CONTRACTOR AND OWNER.**

CPL

ARCHITECT *(Firm name)*



SIGNATURE

Kisha Patterson, AIA, Project Architect

PRINTED NAME AND TITLE

09/21/2023

DATE

Weaver Metal and Roofing, Inc.

CONTRACTOR *(Firm name)*

SIGNATURE

PRINTED NAME AND TITLE

DATE

Niagara Falls Water Board

OWNER *(Firm name)*

SIGNATURE

PRINTED NAME AND TITLE

DATE



**A** 40 APPENHEIMER AVENUE  
BUFFALO NY 14214  
**P** 716.891.8844  
**F** 716.891.9443  
**W** WEAVERMIRINC.COM

Date: 9/12/2023

Job Reference:

To

Niagara Falls Water Treatment Plant Roof Reconstruction  
3815 Buffalo Ave  
Niagara Falls, NY 14304

CPL Architecture  
26 Mississippi St, Buffalo, NY 14203  
Attention: Kisha Patterson

Change Order #1: Modification to Perimeter Detail

LABOR	RATE	HOURS	COST
1 SM Journeymen (Fabricate Lock/Coping)	\$ 86.02	(80.0)	\$ (6,881.60)
2 SM Journeymen (Install Coping/Lock)	\$ 86.02	(295.0)	\$ (25,375.90)
3 R Journeymen (Install Plywood)	\$ 75.68	130.0	\$ 9,838.40
4 SM Journeymen (Fabricate Cover)	\$ 86.02	30.0	\$ 2,580.60
5 SM Journeymen (Install Cleat/Lock)	\$ 86.02	220.0	\$ 18,924.40

MATERIAL	UNIT	QUANTITY	\$ PER UNIT	COST
1 050 Aluminum Flat Stock (Coping)	sheet	-287	\$ 150.36	\$ (43,153.32)
2 20 ga Galvanized Sheet (Cleats)	sheet	-150	\$ 87.09	\$ (13,063.50)
3 SureTite 5.25" Fascia Cleat (120 per cart)	carton	25	\$ 505.00	\$ 12,625.00
4 050 Aluminum Fascia (Fascia Cover)	sheet	95	\$ 150.36	\$ 14,284.20
5 1/2" Plywood	sheet	500	\$ 28.65	\$ 14,325.00
6 Misc. Fasteners	each	1	\$ 400.00	\$ 400.00

SUBCONTRACTOR	UNIT	QUANTITY	\$ PER UNIT	COST
1				\$ -
				\$ -
<b>LABOR TOTAL</b>				<b>\$ (914.10)</b>
<b>MATERIAL TOTAL</b>				<b>\$ (14,582.62)</b>
<b>SUBCONTRACTOR TOTAL</b>				<b>\$ -</b>
<b>15% O&amp;P</b>				<b>\$ -</b>
<b>TOTAL</b>				<b>\$ (15,497.00)</b>

Notes

Existing substrate at top and interior face of wall is not suitable to install EPDM flashings direct, need to install plywood to provide suitable substrate, to minimize costs, modify detail to eliminate coping and install Carlisle SureTite Cleat with shop fabricated 050 aluminum fascia cover. See attached RFI-01 for reference.

9/14/23 - Rcv'd by CPL

Thank you for using Weaver Metal and Roofing, Inc. as the provider of roofing services for this project.

Authorized Signature
This proposal may be withdrawn by us if not accepted within 30 days.
  <i>(Contractor's Signature)</i>

(Date)

Acceptance of Proposal
The above prices, specifications and conditions are hereby accepted.
  <i>(Authorizing Signature)</i>

(Date)



ARCHITECTURE  
ENGINEERING  
PLANNING  
CPLteam.com

<b>REQUEST FOR INFORMATION</b>	<b>RFI #:</b> 01
	<b>Date:</b> 9/14/2023

**WTP – ROOF RECONSTRUCTION – R20.14143.02**

**Contractor Name:** Weaver Metal & Roofing, Inc.

**To:** Kisha Patterson **Firm:** CPL

**From:** Brian Petersdorf

**WE REQUEST YOUR ATTENTION (OR CONFIRMATION) REGARDING THE FOLLOWING:**

**Subject:** Roof Edge / Expansion / Coping (Detail 1 & 9 A800)

**Location:** All roof areas

**Information is Requested By:** ASAP - We begin laying up roof 9/19/23

**MESSAGE:** See attached documents

**Note:** This change will not effect the Carlisle Total Systems Warranty, the original warranty as specified will be the same.

**Contractors Name:** Weaver Metal & Roofing Inc.

**By:** *brian petersdorf*

**Date:** 9/14/2023

9/18/23 - Rcv'd by CPL

Updated warranty info added to change order.

CPL  
26 Mississippi Street  
Suite 100  
Buffalo, NY 14203  
CPLteam.com  
716.852.2100 TEL  
800.274.9000 TEL





**CONTRACTOR**

Weaver Metal & Roofing, Inc.  
40 Appenheimer Avenue  
Buffalo, NY 14214



Overview of flashing after coping was removed.



Portion of flashing and substrate was removed. Adhered directly to plywood and cannot be removed without destroying plywood substrate. EPDM flashings cannot be adhered to existing membrane.





**CONTRACTOR**

Weaver Metal & Roofing, Inc.  
40 Appenheimer Avenue  
Buffalo, NY 14214



View of exterior edge of flashing/blocking. Existing did not properly cover wood blocking onto stone.

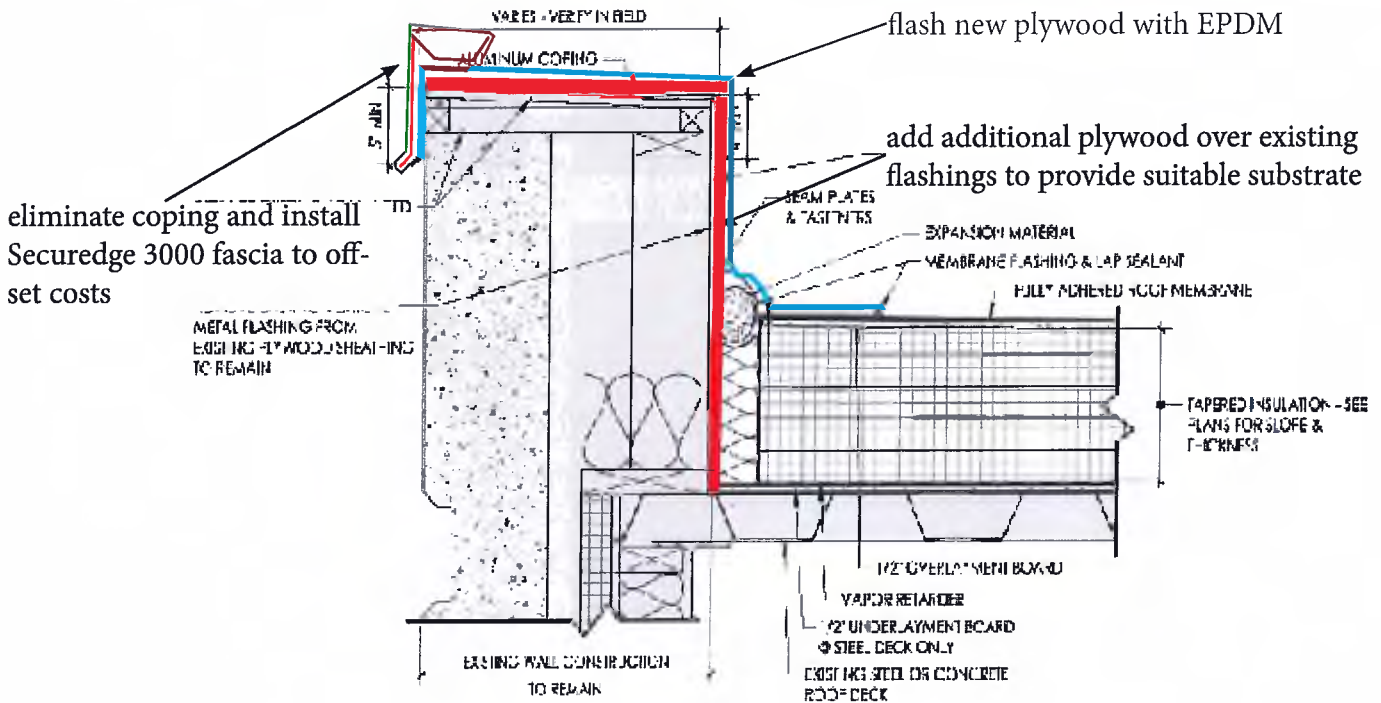

9 **ROOF EDGE / EXPANSION / COPING**  
1/2" - 1/4"

# SureTite™ Snap-On Fascia Cleat



## Overview

Carlisle SynTec Systems' SureTite Snap-On Fascia Cleat is a continuous, 22-gauge Galvalume® cleat that is available in 12' lengths. This product features pre-punched holes for fasteners spaced 12" on center. The Snap-On Fascia Cleat may be used with the edge metal when Carlisle metal flat sheets are used to shop-fabricate the cover.

The Snap-On Fascia Cleat may be used for two types of edge profiles: fascia and tapered coping. The cleat is offered in various sizes to accommodate the wood nailers required for the project.

## Features and Benefits

- » Prefabricated cleat for consistency and convenience
- » Fasteners included for proper attachment
- » Packaged in 10-piece bundles for easy handling
- » Included in the Total System Warranty
- » Can be delivered with roofing materials
- » Several sizes from 4¼" - 8¼" face heights
- » Meets The International Building Code's (IBC) requirements for ES-1 compliance

## Warranty

When utilizing Carlisle's SureTite Snap-On Fascia Cleat and Carlisle's shop-fabricated metal flat sheets, the metal edge will be included in the Carlisle Total System Warranty. Wind speed warranties up to 80 MPH will be available. Face covering must meet Carlisle specifications for fabrication.

## Benefits of ES-1 Certification

- » Reduce liability by maintaining International Building Code (IBC) compliance
- » Achieve an edge-to-edge warranty on a Carlisle roof system (up to 20 yr, 80 mph)
- » Receive a 30-year paint finish warranty
- » Obtain project compliance certificates (issued upon request)

## Typical Properties and Characteristics

Size	4¼", 5¼", 6¼", 8¼" heights; Provided in 12' lengths	
Material	22-gauge Galvalume steel	
Face Cover Requirements	Minimum 24-gauge Fabricated to Carlisle specifications (available on Carlisle website)	
Packaging	10-piece bundles Screw fasteners to meet 12" on center attachment	
	Pallet	
	Quantity	Weight
	4¼" - 250 Pcs	1,560 lbs.
	5¼" - 250 Pcs	1,895 lbs.
	6¼" - 200 Pcs	1,814 lbs.
	8¼" - 200 Pcs	2,358 lbs.

Typical properties and characteristics are based on samples tested and are not guaranteed for all samples of this product. This data and information is intended as a guide and does not reflect the specification range for any particular property of this product.

# SureTite Snap-On Fascia Cleat

## Snap-On Fascia Profile

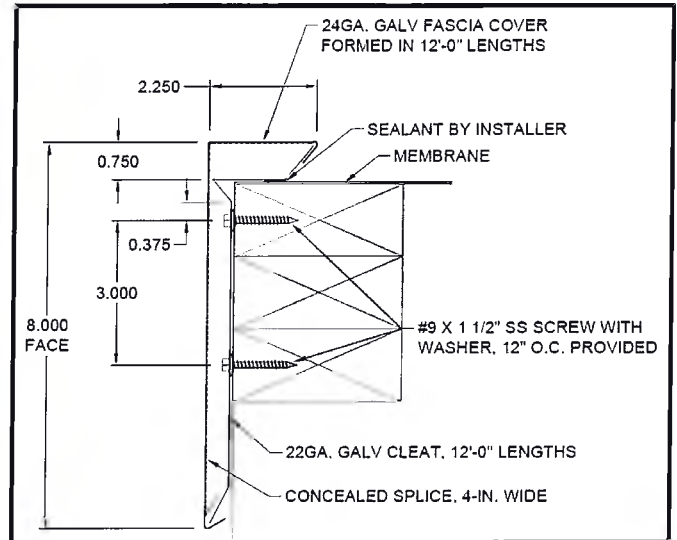
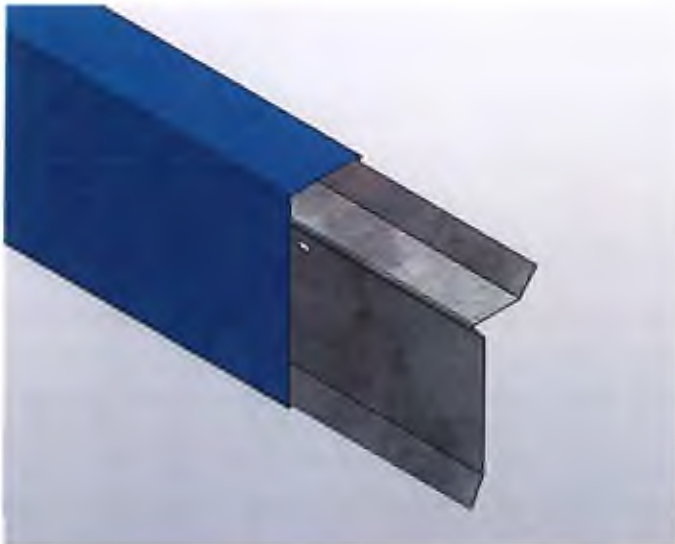

## Tapered Coping Profile

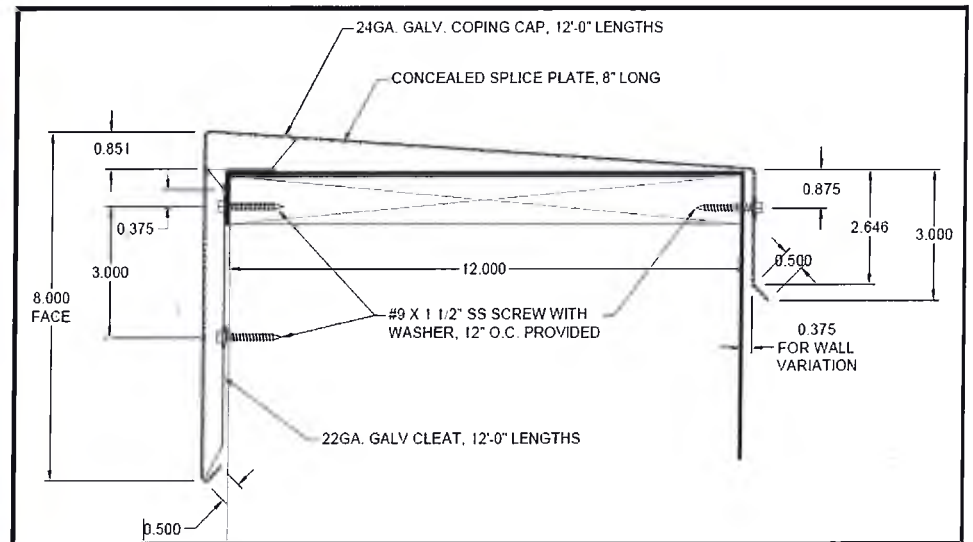





**Beech Ave Project**







**Beech Ave Project**



**Sedimentation Basin 3  
Concrete Work**



**Niagara Falls Water Board  
Personnel Actions and Report  
Monday, September 25, 2023**

**Personnel Actions Sheet & Requested of the Board.  
All appointments are subject to the appointee meeting the minimum qualifications and all applicable civil service conditions.**

<b>A. PERSONNEL ACTIONS RECOMMEND TO HIRE</b>				
<b>Line Item Number</b>	<b>Position</b>	<b>Department/Location</b>	<b>Pay Rate or Grade</b>	<b>ADDITIONAL INFORMATION</b>

<b>B. RECOMMENDED PROMOTION / MOVE / APPOINTMENT</b>				
<b>Line Item Number</b>	<b>Name and Position</b>	<b>Type of labor move</b>	<b>Change in pay rate or grade</b>	<b>ADDITIONAL INFORMATION</b>
1	Michael Eagler, Sr Chief Outside Ops		<u>\$1,500/wk Stipend</u>	Acting Executive Director Position

<b>C. PREVIOUSLY TABLED PERSONNEL ACTIONS (From 2021)</b>				
<b>Line Item Number</b>	<b>Action and Position</b>	<b>Department/Location</b>	<b>Pay Rate or Grade</b>	<b>ADDITIONAL INFORMATION</b>

<b>D. OTHER PERSONNEL ACTIVITY FOR BOARD NOTIFICATION</b>				
<b>Name</b>	<b>Position</b>	<b>Department/Location</b>	<b>Pay Rate</b>	<b>ADDITIONAL INFORMATION</b>
Joseph Morock	System Eng	IT		Resignation effective 9/1/23
Corinne Willett	Lab Tech	WTP Lab		Resignation effective 9/1/23
A Zehraoui	Executive Director	WTP/WWTP		Resignation effective 9/8/23

<b>E. PERSONNEL ON LONG TERM LEAVE OF ABSENCE</b>				
<b>Name</b>	<b>Last Day Worked</b>	<b>Dept.</b>	<b>Return Status</b>	<b>Comments</b>
Lisa Landers	9/1/2023	Admin	Unknown	FMLA
Glenn Choolokian	9/6/2023	WWTP Maint	Unknown	Workers Comp
Vincent Virtuoso	7/12/2023	Meter Maint	Unknown	Workers Comp

*NIAGARA FALLS WATER BOARD RESOLUTION # 2023-09-001*

**AWARD BID FOR 16 INCH CONCRETE WATER MAIN REPAIR  
AT HIGHLAND AND COLLEGE AVENUES**

**WHEREAS**, the Niagara Falls Water Board (“Water Board”) discovered a broken 16” concrete water main near the intersection of Highland and College Avenues; and

**WHEREAS**, repairs to prestressed concrete pressure pipe water mains like the one at issue require specialty skills and equipment that the Water Board does not have in house; and

**WHEREAS**, the City of Niagara Falls Engineering Department prepared plans for the needed water main repair and associated restoration of sidewalks, curbs, and the street, and two bids for the project were received on August 24, 2023; and

**WHEREAS**, the low bid for the 16” diameter prestressed concrete pressure pipe water main repair is from 4<sup>th</sup> Generation Construction Co., at a total base bid item price of \$85,900;

\* CONTINUED ON NEXT PAGE \*



**NOW THEREFORE BE IT**

**RESOLVED**, that the Niagara Falls Water Board hereby awards the bid for the for the 16” diameter prestressed concrete pressure pipe water main repair project near the corner of Highland and College Avenues to 4<sup>th</sup> Generation Construction Co., for that firm’s total base bid item price of \$85,900.

*Water Board Personnel Responsible for Implementation of this Resolution:*  
Executive Director

*Water Board Budget Line or Capital Plan Item with Funds for this Resolution:*  
W-30, Water Infrastructure Projects-Miscellaneous  
Capital Line Supplied by: D. Williamson  
Capital Line Confirmed by: B. Majchrowicz

On September 25, 2023, the question of the adoption of the foregoing Resolution was duly put to a vote on roll call, which resulted as follows:

	<b>Yes</b>	<b>No</b>	<b>Abstain</b>	<b>Absent</b>
Board Member Asklar	[ ]	[ ]	[ ]	[ ]
Board Member Kimble	[ ]	[ ]	[ ]	[ ]
Board Member Larkin	[ ]	[ ]	[ ]	[ ]
Board Member Leffler	[ ]	[ ]	[ ]	[ ]
Chairman Forster	[ ]	[ ]	[ ]	[ ]

Signed By:

Vote Witnessed By:

\_\_\_\_\_  
Nicholas J. Forster, Chairman

\_\_\_\_\_  
Sean W. Costello, Secretary to Board



# City of Niagara Falls, New York

P.O. Box 69, Niagara Falls, NY 14302-0069

**ENGINEERING DEPARTMENT**

August 24, 2023

**Niagara Falls Water Board**

Mayor Michael C. O'Laughlin  
Niagara Falls Water Treatment Facility  
5815 Buffalo Avenue  
Niagara Falls, New York 14304

Attention: Dr. Abderrahman Zehraoui  
Executive Director

Dr. Zehraoui:

Attached to this brief letter please find the standard City of Niagara Falls Bid Tabulation Summary Sheet(s) for the following project:

**16" DIA. PCCP WATER MAIN REPAIR PROJECT  
HIGHLAND and COLLEGE AVENUES**

Arithmetical and typographical errors (if any) have been corrected and noted and the entire package is offered for your continued review, reference, and ultimate contract award. The verified and qualified low bidder for this project is:

**4<sup>TH</sup> GENERATION CONSTRUCTION CO.  
5650 SIMMONS AVENUE  
NIAGARA FALLS, NEW YORK 14304**

at the total base bid item price of: **\$ 85,900.00**

Please contact me at your convenience if questions arise or additional clarification is deemed necessary.

Sincerely,

Robert Buzzelli  
Civil Engineer III

attachments: (1)

cc: file

**CONTRACT: - 16" PCCP WATERMAIN REPAIR PROJECT  
HIGHLAND and COLLEGE AVENUES**

BID OPENING: AUGUST 24, 2023

TIME: 2:00 p.m.

SHEET 01 OF 01

BID SECURITY: - N.A. -

#	BID ITEM	QTY.	UNIT	MARK CERRONE, INC.				4TH GENERATION CONSTRUCTION, INC.	
				PRICE	AMOUNT	PRICE	AMOUNT		
1	CONCRETE PIPE REPAIR	20	L.F.	3,142.00	62,840.00			2,900.00	58,000.00
2	PAVEMENT SAWCUTTING	50	L.F.	24.00	1,200.00			5.00	250.00
3	MISCELLANEOUS SAWCUTTING	60	L.F.	10.00	600.00			5.00	300.00
4	NEW CONCRETE CURBING	30	L.F.	159.00	4,770.00			60.00	1,800.00
5	FOUR (4") INCH THICK CONCRETE SIDEWALKS	75	S.F.	56.00	4,200.00			10.00	750.00
6	SIX (6") INCH THICK CONCRETE SIDEWALKS, APRONS, RAMPS	450	S.F.	27.00	12,150.00			12.00	5,400.00
7	SUBBASE COURSE COURSE - TYPE 7 (1-1/2" THK.)	30	S.Y.	71.00	2,130.00			20.00	600.00
8	PORTLAND CEMENT CONCRETE BASE COURSE, TYPE F	30	S.Y.	144.00	4,320.00			20.00	600.00
9	ASPHALT CONCRETE BINDER COURSE - TYPE 3 (3" THK.)	30	S.Y.	92.00	2,760.00			20.00	600.00
10	ASPHALT CONCRETE TOP COURSE - TYPE 7 (1-1/2" THK.)	30	S.Y.	90.00	2,700.00			20.00	600.00
11	MAINTENANCE AND PROTECTION OF TRAFFIC	1	L.S.	26,330.00	26,330.00			14,000.00	14,000.00
12	MOBILIZATION	1	L.S.	4,900.00	4,900.00			3,000.00	3,000.00

☆ - FIGURE ADJUSTED TO ARITHMETICALLY-CORRECT DOLLAR AMOUNT

**\$128,900.00**

2

**\$85,900.00**

1

**PROCUREMENT OF WATER METERS**

**WHEREAS**, the Niagara Falls Water Board (“Water Board”) has standardized on Neptune brand meters for residential and large meter installations as it has invested in the equipment required for remote reading, testing, calibration, and repair of Neptune meters; and

**WHEREAS**, the meter shop has depleted its inventory of new meters, which are required to replace defective meters that cannot be repaired, to replace meters that no longer meet accuracy standards, or for new installations; and

**WHEREAS**, TiSales is the exclusive distributor of Neptune brand meters and components in this region;

**NOW THEREFORE BE IT**

**RESOLVED**, that on behalf of the Niagara Falls Water Board, its Executive Director hereby is authorized to procure from TiSales an assortment of water meters and components meeting the needs identified by the meter shop, for a total cost not to exceed \$144,855.90.

*Water Board Personnel Responsible for Implementation of this Resolution:*  
Executive Director

*Water Board Budget Line or Capital Plan Item with Funds for this Resolution:*  
Capital Plan Line: C-2, Meter Replacement and Upgrades  
Capital Line Supplied by: D. Williamson  
Budget Line Confirmed by: B. Majchrowicz

On September 25, 2023, the question of the adoption of the foregoing Resolution was duly put to a vote on roll call, which resulted as follows:

	<b>Yes</b>	<b>No</b>	<b>Abstain</b>	<b>Absent</b>
Board Member Asklar	[   ]	[   ]	[   ]	[   ]
Board Member Kimble	[   ]	[   ]	[   ]	[   ]
Board Member Larkin	[   ]	[   ]	[   ]	[   ]
Board Member Leffler	[   ]	[   ]	[   ]	[   ]
Chairman Forster	[   ]	[   ]	[   ]	[   ]

Signed By:

Vote Witnessed By:

\_\_\_\_\_  
Nicholas J. Forster, Chairman

\_\_\_\_\_  
Sean W. Costello, Secretary to Board



800-225-4616  
 978-443-2002  
 Fax: 978-443-7600  
 www.tisales.com

Quote	QTE0065073
Quoted To	Bob
Date	09/11/2023

**Sold To:** Niagara Falls Water Board  
 5815 Buffalo Ave.  
 Niagara Falls NY 14304-3832

**Ship To:** Niagara Falls Water Board  
 5815 Buffalo Ave.  
 Niagara Falls NY 14304

Customer Number	Telephone	Fax	Job Location	Job Name	Territory Manager
NIAG7	(716) 286-4371	(716) 283-9748	Niagara Falls NY	FY Capital Purchase	Marcus Anten
Expires	Estimated Delivery	Freight		Terms	Master Number
11/10/2023	TBD	Allowed		NET 30	364931
Item Number	Description	Quantity	Price	Extension	
N4EIFPIT	1" Neptune T-10 Meter Integrated E-CODER R900i Cubic Feet	8	\$532.30	\$4,258.40	
N2EIFPIT	5/8" X 3/4" Neptune T-10 Meter Integrated E-CODER R900i Cubic Feet	144	\$350.77	\$50,510.88	
N6EIFPIT	1-1/2" Neptune T-10 Meter Integrated E-CODER R900i Cubic Feet Flanged End	6	\$944.61	\$5,667.66	
N7EIFPIT	2" Neptune T-10 Meter Integrated E-CODER R900i Cubic Feet Flanged End	3	\$1,163.84	\$3,491.52	
NCOMP3EIF	3" Neptune Tru/Flo Compound Meter Integrated E-CODER R900i Cubic Feet	4	\$3,796.92	\$15,187.68	
NCOMP4EIF	4" Neptune Tru/Flo Compound Meter Integrated E-CODER R900i Cubic Feet	2	\$4,829.99	\$9,659.98	
NCOMP6EIF	6" Neptune Tru-Flo Compound Meter Integrated E-CODER R900i Cubic Feet	2	\$7,896.15	\$15,792.30	
9596-352	6" Neptune Tru/Fo Compound UME Integrated E-CODER R900i Cubic Feet	4	\$5,495.72	\$21,982.88	
R900V4	Neptune R900 RF Endpoint Wall Mount V4	20	\$163.25	\$3,265.00	
RW2F13	5/8" Neptune T-10 Register Integrated E-CODER R900i Cubic Feet	60	\$250.66	\$15,039.60	
Quoted By: Steve Moran					
				Subtotal	\$144,855.90
				Other Charges	\$0.00
				Tax	\$0.00
				<b>TOTAL DUE</b>	<b>\$144,855.90</b>
<b>Visit our website @ <a href="http://www.tisales.com">www.tisales.com</a></b>					

*If you are in agreement with this quote and wish to order, please sign, date, and fax back to 978-443-7600 or email us at [orders@tisales.com](mailto:orders@tisales.com)*

Signature: \_\_\_\_\_ Date: \_\_\_\_\_



September 27, 2022

ATTN: Mr. Sean Costello  
Niagara Falls Water Board  
5815 Buffalo Avenue  
Niagara Falls, NY 14304

To Whom it May Concern:

Neptune Technology Group Inc. utilizes exclusive distributors for our water meter products and services.

Ti- SALES Inc. is the authorized stocking distributor for Neptune Technology Group Inc for the six New England states and upstate/western New York.

Ti-SALES is the only Neptune Level One distributor with manufacturer's approval to sell Neptune products in your area of New York.

If you have any questions or need additional information, please call me at (585) 315-3287.

Regards,

David Johnson  
Territory Manager  
Neptune Technology Group Inc

Cc: M. Anten – Ti Sales Inc.  
Z. Mendes - NTG

**LABOR FOR INSTALLATION OF FIRE ALARMS**

**WHEREAS**, the Niagara Falls Water Board (“Water Board”) Water Treatment Plant (“WTP”) fire alarm system has experienced multiple false alarms and system failures because components of the system originally installed in the filter gallery area were susceptible to damage from the high humidity conditions there; and

**WHEREAS**, Water Board staff worked with Johnson Controls to develop a plan to replace the existing sensors and other fire alarm system components in the filter gallery area with more appropriate sealed and humidity proof devices, and the Water Board has procured these devices; and

**WHEREAS**, Water Board personnel did not feel they could complete the wiring and reprogramming work necessary to complete installation of the new devices, and Johnson Controls has provided a quotation dated August 14, 2023 to perform the necessary labor for a total cost of \$23,999.22; and

**WHEREAS**, this procurement is made pursuant to NYS Office of General Services Contract No. PT68816, from Contract Group 77201, Intelligent Facility and Security Systems & Solutions, and thus the procurement satisfies applicable competitive procurement and prevailing wage requirements;

\* CONTINUED ON NEXT PAGE \*

**NOW THEREFORE BE IT**

**RESOLVED**, that on behalf of the Niagara Falls Water Board, its Executive Director hereby is authorized to pay to Johnson Controls Fire Protection LP an amount not to exceed \$23,999.22 to perform the wiring, conduit installation, programming, and other tasks described in that firm’s August 14, 2023 quotation.

*Water Board Personnel Responsible for Implementation of this Resolution:*  
Executive Director

*Water Board Budget Line or Capital Plan Item with Funds for this Resolution:*  
Capital Plan Line: WTP 7 – WTP Infrastructure Projects - Miscellaneous  
Capital Line Supplied by: D. Williamson  
Budget Line Confirmed by: B. Majchrowicz

On September 25, 2023, the question of the adoption of the foregoing Resolution was duly put to a vote on roll call, which resulted as follows:

	<b>Yes</b>	<b>No</b>	<b>Abstain</b>	<b>Absent</b>
Board Member Asklar	[ ]	[ ]	[ ]	[ ]
Board Member Kimble	[ ]	[ ]	[ ]	[ ]
Board Member Larkin	[ ]	[ ]	[ ]	[ ]
Board Member Leffler	[ ]	[ ]	[ ]	[ ]
Chairman Forster	[ ]	[ ]	[ ]	[ ]

Signed By:

Vote Witnessed By:

\_\_\_\_\_  
Nicholas J. Forster, Chairman

\_\_\_\_\_  
Sean W. Costello, Secretary to Board





Johnson Controls Fire Protection LP  
6850 Main Street, Suite 3  
Williamsville, NY 14221  
(716) 633-8465

## Johnson Controls Fire Protection LP Quotation

To:  
Niagara Falls Water Board  
5815 Buffalo Ave  
NIAGARA FALLS, NY 14304-3832

Project: NFWB FAS PULL STATION ADDITIONS CO1  
INSTALL LABOR - CPQ-450057  
Johnson Controls Reference: 650450057  
Proposal #: 1  
Date: 08/14/2023  
Page: 1 of 14

Johnson Controls is pleased to offer for your consideration this quotation for the above project

### Scope of Work

Dear Mr. Russ DeFranco.

First we, Johnson Controls, want to thank you for the opportunity to provide this quotation to you for the NIAGARA FALLS WATER BOARD PULL STATIONS ADDITIONS PROJECT CO1 INSTALLATION LABOR and the related associated with the original approval for the project and the Fire Alarm System Deprogramming / Pull Station Additions in the three (3) water associated areas on the 2<sup>nd</sup> Floor reviewed and discussed. We understand that your organization will perform directly with regards to the smoke sensor removals and we, JCFP and our subcontractor, will perform with the required installation of rigid conduit and alike with this change order. We will accomplish with the listed parts from the base project and extend rework conduit for the interconnection of the "New" Pull Stations.

Johnson Controls Scope of Work for this project is as follows:

Supply the listed installation labor and materials detailed for Pull Station Additions as shown and detailed on the related drawings referenced below in the Waste Treatment Storage, Pretreatment Tanks and Filter Gallery Areas. As previously detailed this project as detailed herein in a joint effort between the maintenance staff at NFWB and JFCP. NFWB is still responsible for the removal of all smoke sensors following the installation of the "New" Pull Stations by JCFP and our subcontractor.

It is understood that our organization will now be installing the required conduit raceway and wiring and all field devices, Pull Stations, at the NFWB and to be added in addition to subsequent reprogramming at the facp due to the point type changing and device additions.

Fire, Security, Communications, Sales & Service  
Offices & Representatives in Principal Cities throughout North America



After receipt of your approval installation coordination will be accomplished by JCFP where our assigned project manager will give direction to our staff and subcontractor for the installation thereof. With the base project scope as with this one following the installation efforts the our field technician will respond to the site and accomplish all system reprogramming and alike at the FACP. Following the inspection with specific highlights to these twenty eight (28) devices to be removed and the additions of the eleven pull stations and associated hardware/ equipment to be on the report which will be forwarded to your attention for related filing.

Following installation, programming, testing and certification tasks all NFPA compliant reports will be forwarded to your attention at NFWB with a "new" Point / Panel Configuration List.

JOHNSON CONTROLS FIRE PROTECTION EXEMPTIONS/CLARIFICATIONS: Johnson Controls is not responsible for the design. Additional devices may be deemed necessary by the AHJ and could result in additional cost.

THIS PROPOSAL IS BASED UPON ONLY THOSE ITEMS DENOTED BY [X]":

- Specification section:
- Information on drawings, sheets: NFWB Drawings E-37 dated 02-07-94 and modified by JCFP on 12-27-22
- Up to and including addendum:
- Customer / JCFP review of bill of material:
- Verbal / Email Request: July-2023 (Installation by JCFP)
- Value engineering:
- Design Build:

THIS QUOTATION INCLUDES ONLY THOSE ITEMS DENOTED BY "[X]":

NOTE: As Johnson Controls Fire Protection is to accomplish the pull station installation with this system modification our organization and retained electrical contractor and staff, Ferguson Electric -- Buffalo New York, will install all listed parts and if required provide and install all. All conduits to be installed above ground/grade of the floor and will be open installation with the exception of the admin hallway between the tank areas.

- Equipment as listed ONLY
- Technical and District Labor as detailed above
- Installation as listed ONLY and wire installed within installed "rigid / emt " raceways
- Equipment as listed ONLY and wire installed within customer installed complete raceway

systems with pull-strings

- Demolition



- Cutting, Drilling and Firestopping
- Patching and Painting
- New York State Sales Tax
- Freight (F.O.B. shipping point)
- Shop Drawings/As-Builts (Risers Only)
- Shop Drawings/Asbuilt (Floor Plans and Riser Diagrams)
- Submittals ( Note they will include installation information and drawings associated with the project)
- Sealed Drawings
- Panel terminations
- Lift for access above 12 feet
- Technical installation support including programming
- Permit
- Inspection Fees for one (1) inspection - Multiple inspections for phased acceptance is not included
- Payment/Performance Bonds
- Pre-Test
- 1 functional system certification test (New Devices Only-Base Bid Costs cover this task)
- 1 AHJ test
- NFPA certification documentation
- One-year standard warranty
- Three Year Extended Warranty
- Monitoring
- Training
- AHCA Inspection
- UL Certification
- Prevailing Wages
- Tax

THIS QUOTATION DOES NOT INCLUDE THE FOLLOWING:

Equipment above listed.

Device Testing (Testing to be in conjunction with annual fire alarm inspection associated with annual service contract in place between NFWB and JCFP)

Installation Services (By NFWB with regards to removals in tank areas)

Technical Support outside listed

Fire protection switches or gas solenoids (none on this project)

Phone lines



Johnson Controls Fire Protection LP  
6850 Main Street, Suite 3  
Williamsville, NY 14221  
(716) 633-8465

Troubleshooting of the existing wiring  
Replacement and or relocation of End of Line Resistors (EOL's) on any and all initiation and notification circuits  
Remote station monitoring contract (available upon request)  
Knox box  
Cutting, drilling or fire caulking  
Patching  
Painting  
Final Interconnection and Interface to non-Johnson Controls provided equipment i.e.: HVAC, Sprinkler and elevator  
Fire watch  
Weatherproof and conditioned control equipment housing  
Submittals  
Construction Drawings  
Cost for CAD files  
Tax

If SimplexGrinnell is awarded this project we will need:

- A complete schedule prior to start of work, and any updates
  - Five (5) business days notice for all technical labor for programming and or inspections
  - A copy of the Asbestos report if applicable
  - A copy of the Tax Exempt certificate if applicable
- Autocad Drawings within 5 days of authority to proceed.  
Your Purchase Order or contract with specific reference this proposal #, date and amount

Invoicing will be accomplished meeting Johnson Controls Guidelines. Within ten (10) days of approval to proceed the assigned project manager/operations manager will coordinate a face to face / tele-conference to determine the Schedule of Values (SOV).

Invoicing will be accomplished for all equipment delivered to project site or staging area, regardless of Johnson Controls or customer warehouse. Related invoicing will also be accomplished for district related labor for submittals, drawings and project management as it transpires and is listed above.

Additional work, beyond this scope of work, will require a signed change order prior to installation.

Fire, Security, Communications, Sales & Service  
Offices & Representatives in Principal Cities throughout North America



Johnson Controls Fire Protection LP  
6850 Main Street, Suite 3  
Williamsville , NY 14221  
(716) 633-8465

Incorrect installation of wire, conduit or back boxes is solely the responsibility of your organization and or your retained electrical contractor associated with the project.

Quotation is based on free access to work areas. Limited access or unusual obstructions (i.e.: working through installed ceiling grid, working overtop of equipment installed on the floor, etc.) could result in added costs.

Quotation is valid for a period of 30 days ONLY unless modified in writing by SimplexGrinnell.

Note this quotation was generated with New York State Contract for Purchasing PT68816 dated 08-23-2022. Note the following line items for equipment and labor and their summaries.

Labor	
Region 9 Project Mgt 204.87 EACH W TOTAL OF 6	1,229.22
<hr/>	
LABOR TOTAL OF	1,229.22

Labor	
Outside Labor/Contracting (19,800 plus 15%)	22,770.00

GRAND TOTAL OF	23,999.22
----------------	-----------

All parts and related components if returned will have a 30% restocking charge applied. Note all parts and components will only be returned for credit is an unopened undamaged box with appropriate labeling intact. Note some individual parts such as back boxes and related trim rings etc. are not able to be returned for credit.

All work is to be performed during normal Johnson Controls Fire Protection hours of 7am to 3:30pm Monday through Friday with the exception of company sponsored holidays unless specifically noted otherwise.

In closing, we, Johnson Controls Fire Protection, looks forward to the commencement of this project and assisting you in your position. If any questions arise please contact me directly at (716) 633 8465 or via cell at (716) 574 9575.

Regards,

  
Richard FitzGerald

Fire, Security, Communications, Sales & Service  
Offices & Representatives in Principal Cities throughout North America



Johnson Controls Fire Protection LP  
6850 Main Street, Suite 3  
Williamsville , NY 14221  
(716) 633-8465

Account Executive

Fire, Security, Communications, Sales & Service  
Offices & Representatives in Principal Cities throughout North America



**NFWB CO1 DISTRICT LABOR**

QTY	MODEL NUMBER	DESCRIPTION
6	PM LAB	PROJECT/CONSTRUCTION MGMT

**NFWB CO1 INSTALLATION LABOR**

QTY	MODEL NUMBER	DESCRIPTION
1	DPINSTAL	SUB INSTALL LABOR

**Total net selling price, FOB shipping point, \$23,999.22**

Johnson Controls has **not** included an estimate for all state and local sales tax for this quote based on the understanding that a valid exemption and/or resale certificate is received by Johnson Controls from Purchaser. Otherwise, actual sales tax due will be calculated and billed

**Payment Options:**

**Johnson Controls Capital Funding Solutions**

Equipment Finance Agreement: Allows for payment over time for products and installation costs, while maintaining ownership of assets. No down payment required.

As a Service Subscription: Covers costs of installation and services over time without ownership of assets. No upfront costs.

*\*\*Final pricing subject to change based on credit approval, any applicable state/local taxes\*\**

**For more information on Johnson Controls Capital funding solutions, please forward this proposal along with any questions to your sales representative and [JCCapitalNA@jci.com](mailto:JCCapitalNA@jci.com).**



**IMPORTANT NOTICE TO CUSTOMER**

This Agreement is contingent on credit approval, which may be checked at JCI's discretion and requires final approval of a JCI authorized manager before any equipment/ services may be provided. Should credit and/or approval be declined, this Agreement will be terminated and JCI's only obligation to customer will be to notify Customer of such termination and refund any amounts paid in advance. In accepting this Proposal, Customer agrees to the terms and conditions contained herein and any attachments or riders attached hereto that contain additional terms and conditions. It is understood that these terms and conditions shall prevail over any variation in terms and conditions on any purchase order or other document that the Customer may issue. Any changes in the system requested by the Customer after the execution of this Agreement shall be paid for by Customer and such changes shall be authorized in writing. **ATTENTION IS DIRECTED TO THE LIMITATION OF LIABILITY, WARRANTY, INDEMNITY AND OTHER CONDITIONS ON THE PRECEDING PAGES. This proposal shall be void if not accepted in writing within 30 days from the date of the Proposal.**

For Customers located in Canada, this Fire Domain Sale and Installation Agreement has been drawn up and executed in English at the request of and with the full concurrence of Customer. Ce contrat a été rédigé en anglais à la demande et avec l'assentiment du client.

Unless otherwise agreed to by the parties, pricing is based upon the following billing and payment terms: Invoices will be delivered via email, payment due date of NET 30, deposit for a minimum of 30% of the sell price, and the invoices are to be paid via ACH/EFT bank transfer. Johnson Controls ACH/EFT bank transfer details will be forth coming upon contractual agreement.

This offer shall be void if not accepted in writing within thirty (30) days from the date first set forth above.

To ensure that JCI is compliant with your company's billing requirements, please provide the following information:

PO is required to facilitate billing:  NO: This signed contract satisfies requirement  
 YES: Please reference this PO Number: \_\_\_\_\_

AR Invoices are accepted via e-mail:  YES: E-mail address to be used: \_\_\_\_\_  
 NO: Please submit invoices via mail  
 NO: Please submit invoices via \_\_\_\_\_

<p>Offered By:          Johnson Controls Fire Protection LP          6850 Main Street, Suite 3            Williamsville , NY 14221          Telephone: (716) 633-8465          Representative: _____          Email: richard.fitzgerald@jci.com</p>	<p>Accepted By: (Customer)          Company: _____          Address: _____          Signature: _____          Title: _____          Date: _____</p>
---	---





**TERMS AND CONDITIONS (Rev. 9/22)**

**1. Payment and Invoicing.** All payments are due net thirty (30) days from the date of invoice. Invoices shall be paid by Customer via electronic delivery via EFT/ACH. Invoicing disputes must be identified in writing within 21 days of the invoice date. Payments of any disputed amounts are due and payable upon resolution. All other amounts remain due within thirty (30) days from the date of the invoice. Work performed on a time and material basis shall be at Company's then-prevailing rate for material, labor, and related items, in effect at the time supplied under this Agreement. Company shall invoice Customer for progress payments to 100% percent based upon equipment delivered or stored, and services performed. In the event project duration exceeds one month, Company reserves the right to submit partial invoices for progress payments for work completed at the project site. Customer agrees to pay any progress invoices in accordance with the payment terms set forth herein. In exchange for close-out documents to be provided by Company, Customer agrees to pay Company the remaining project balance when on-site labor is completed and prior to any final inspections. Customers without established satisfactory credit and Customers who fail to pay amounts when due may be required to make payments of cash in advance, upon delivery or as otherwise specified by Company. Company reserves the right to revoke or modify Customer's credit in its sole discretion. Customer acknowledges and agrees that timely payments of the full amounts listed on invoices is an essential term of this Agreement and that Customer's failure to make payment when due is a material breach of this Agreement. Customer further acknowledges that if there is any amount outstanding on an invoice, it is material to Company and will give Company, without prejudice to any other right or remedy, the right to, without notice: (i) suspend, discontinue or terminate performing any services and/or withhold further deliveries of equipment and other materials, terminate or suspend any unpaid software licenses, and/or suspend Company's obligations under or terminate this Agreement; and (ii) charge Customer interest on the amounts unpaid at a rate equal to the lesser of one and one half (1.5) percent per month or the maximum rate permitted under applicable law, until payment is made in full. Company's election to continue providing future services does not, in any way diminish Company's right to terminate or suspend

services or exercise any or all rights or remedies under this Agreement. Company shall not be liable for any damages, claims, expenses, or liabilities arising from or relating to suspension of services for non-payment. In the event that there are exigent circumstances requiring services or the Company otherwise performs services at the premises following suspension, those services shall be governed by the terms of this Agreement unless a separate contract is executed. If Customer disputes any late payment notice or Company's efforts to collect payment, Customer shall immediately notify Company in writing and explain the basis of the dispute. Customer agrees to pay all of Company's reasonable collection costs, including legal fees and expenses.

**2. Deposit.** Unless prohibited by law, Customer agrees to pay a deposit for a minimum of 30% of the project sell price (pre-tax) prior to Company providing any labor or materials on the project. Company will generate an invoice for the deposit after Company's receipt of a written agreement or order from Customer. Company will not commence work until receipt of the deposit.

**3. Pricing.** The pricing set forth in this Agreement is based on the number of devices to be installed and services to be performed as set forth in the Scope of Work ("Equipment" and "Services"). If the actual number of devices installed or services to be performed is greater than that set forth in the Scope of Work, the price will be increased accordingly. If this Agreement extends beyond one year, Company may increase prices upon notice to the Customer.

All stated prices are exclusive of and Customer agrees to pay any taxes, fees, duties, tariffs, false alarm assessments, installation or alarm permits, and levies or other similar charges imposed and/or enacted by a government, however designated or imposed, including but not limited to value-added and withholding taxes that are levied or based upon the amounts paid under this Agreement. Prices in any quotation or proposal from Company are subject to change upon notice sent to Customer at any time before the quotation or proposal has been accepted. Prices for products covered by this Agreement may be adjusted by Company, upon notice to Customer at any time prior to shipment and regardless of Customer's acceptance of the Company's proposal or quotation, to reflect any increase in Company's cost of raw materials (e.g., steel, aluminum) inability to secure Products, changes or increases in law, labor, taxes, duties, tariffs or quotas, acts of government, any similar charges, or to cover any extra, unforeseen and unusual cost elements.

**4. Alarm Monitoring Services.** Any reference to alarm monitoring services in this Agreement is included for pricing purposes only. Alarm monitoring services are performed pursuant to the terms and conditions of Company's standard alarm monitoring services agreement.

**5. Code Compliance.** Company does not undertake an obligation to inspect for compliance with laws or regulations unless specifically stated in the Scope of Work. Customer acknowledges that the Authority Having Jurisdiction (e.g. Fire Marshal) may establish additional requirements for compliance with federal, state/provincial and local codes. Any additional services or equipment required will be provided at an additional cost to Customer.

**6. Limitation of Liability; Limitations of Remedy.** It is understood and agreed by the Customer that Company is not an insurer and that insurance coverage shall be obtained by the Customer and that amounts payable to company hereunder are based upon the value of the services and the scope of liability set forth in this Agreement and are unrelated to the value of the Customer's property and the property of others located on the premises. Customer agrees to look exclusively to the Customer's insurer to recover for injuries or damage in the event of any loss or injury and that Customer releases and waives all right of recovery against Company arising by way of subrogation. Company makes no guaranty or Warranty, including any implied warranty of merchantability or fitness for a particular purpose that equipment or services supplied by Company will detect or avert occurrences or the consequences therefrom that the equipment or service was designed to detect or avert. It is impractical and extremely difficult to fix the actual damages, if any, which may proximately result from failure on the part of Company to perform any of its obligations under this Agreement. Accordingly, Customer agrees that, Company shall be exempt from liability for any loss, damage or injury arising directly or indirectly from occurrences, or the consequences therefrom, which the equipment or service was designed to detect or avert. Should Company be found liable for any loss, damage or injury arising from a failure of the equipment or service in any respect, Company's liability shall be limited to an amount equal to the Agreement price (as increased by the price for any additional work) or where the time and material payment term is selected, Customer's time and material payments to Company to be calculated with reference to payments made at the time the loss is sustained. Where this Agreement covers multiple sites,



liability shall be limited to the amount of the payments allocable to the site where the incident occurred. Such sum shall be complete and exclusive. In no event shall Company be liable for any damage, loss, injury, or any other claim arising from any servicing, alterations, modifications, changes, or movements of the Covered System(s) or any of its component parts by Customer or any third party. To the maximum extent permitted by law, in no event shall Company and its affiliates and their respective personnel, suppliers and vendors be liable to Customer or any third party under any cause of action or theory of liability, even if advised of the possibility of such damages, for any (a) special, incidental, consequential, punitive or indirect damages of any kind; (b) loss of profits, revenues, data, customer opportunities, business, anticipated savings or goodwill; (c) business interruption; or (d) data loss or other losses arising from viruses, ransomware, cyber-attacks or failures or interruptions to network systems. The limitations of liability set forth in this Agreement shall inure to the benefit of all parents, subsidiaries and affiliates of Company, whether direct or indirect, Company's employees, agents, officers and directors.

**7. Reciprocal Waiver of Claims (SAFETY Act).**

Certain of Company's systems and services have received Certification and/or Designation as Qualified Anti-Terrorism Technologies ("QATT") under the Support Anti-terrorism by Fostering Effective Technologies Act of 2002, 6 U.S.C. §§ 441-444 (the "SAFETY Act"). As required under 6 C.F.R. 25.5 (e), to the maximum extent permitted by law, Company and Customer hereby agree to waive their right to make any claims against the other for any losses, including business interruption losses, sustained by either party or their respective employees, resulting from an activity resulting from an "Act of Terrorism" as defined in 6 C.F.R. 25.2, when QATT have been deployed in defense against, response to, or recovery from such Act of Terrorism.

**8. General Provisions.** Customer has selected the service level desired after considering and balancing various levels of protection afforded, and their related costs. All work to be performed by Company will be performed during normal working hours of normal working days (8:00 a.m. – 5:00 p.m., Monday through Friday, excluding Company holidays), as defined by

Company, unless additional times are specifically described in this Agreement. Company will perform the services described in the Scope of Work section ("Services") for one or more system(s) or equipment as described in the Scope of Work section or the listed attachments ("Covered System(s)"). The Customer shall promptly notify Company of any malfunction in the Covered System(s) which comes to Customer's attention. This Agreement assumes the Covered System(s) are in operational and maintainable condition as of the Agreement date. If, upon initial inspection, Company determines that repairs are recommended, repair charges will be submitted for approval prior to any work. Should such repair work be declined Company shall be relieved from any and all liability arising therefrom. UNLESS OTHERWISE SPECIFIED IN THIS AGREEMENT, ANY INSPECTION(AND, IF SPECIFIED, TESTING)PROVIDED UNDER THIS AGREEMENT DOES NOT INCLUDE ANY MAINTENANCE, REPIARS, ALTERATIONS , REPLACEMENT OF PARTS, OR ANY FIELD ADJUSTMENT WHATSOEVER, NONR DOES IT INCLUDE THE CORECTION OF ANY DEFICIENCIES IDENTIFIES BY COMPANY TO CUSTOMER. COMPANY SHALL NOT BE RESPONSIBLE FOR EQUIPMENT FAILURE OCCURING WHILE COMPANY IS IN THE PROCESS OF FOLLOWING ITS INSPECTION TECHNIQUES, WHERE THE FAILURE ALSO RESULTS FROM THE AGE OR OBSOLESCENCE OF THE ITEM OR DUE TO NORMAL WEAR AND TEAM. THIS AGREEMENT DOES NOT COVER SYSTEMS, EQUIPMENT, COMPONENTS OR PART THAT ARE BELOW GRADE, BEHIND WALLS OR OTHER OBSTRUCTIONS OR EXTERIOR TO THE BUILDING, ELECTRICAL WIRING AND PIPING.

**9. Customer Responsibilities.** Customer shall furnish all necessary facilities for performance of its work by Company, adequate space for storage and handling of materials, light, water, heat, heat tracing, electrical service, local telephone, watchman, and crane and elevator service and necessary permits. Where wet pipe system is installed, Customer shall supply and maintain sufficient heat to prevent freezing of the system. Customer shall promptly notify Company of any malfunction in the Covered System(s) which comes to Customer's attention. This Agreement assumes any existing system(s) are in operational and maintainable condition as of the Agreement date. If, upon initial inspection, Company

determines that repairs are recommended, repair charges will be submitted for approval prior to any work. Should such repair work be declined Company shall be relieved from any and all liability arising therefrom. Customer shall further:

- supply required schematics and drawings unless they are to be supplied by Company in accordance with this Agreement;
- Provide a safe work environment, in the event of an emergency or Covered System(s) failure, take reasonable safety precautions to protect against personal injury, death, and property damage, continue such measures until the Covered System(s) are operational, and notify Company as soon as possible under the circumstances.
- Provide Company access to any system(s) to be serviced,
- Comply with all laws, codes, and regulations pertaining to the equipment and/or services provided under this Agreement.
- Customer is solely responsible for the establishment, operation, maintenance, access, security and other aspects of its computer network ("Network") and shall supply Company secure Network access for providing its services. Products networked, connected to the internet, or otherwise connected to computers or other devices must be appropriately protected by Customer and/or end user against unauthorized access. Customer is responsible to take appropriate measures, including performing back-ups, to protect information, including without limit data, software, or files (collectively "Data") prior to receiving the service or products.

**10. Excavation.** In the event the Work includes excavation, Customer shall pay, as an extra to the contract price, the cost of any additional work performed by Company dues to water, quicksand, rock or other unforeseen condition or obstruction encountered or shoring required.

**11. tructure and Site Conditions.** While employees of Company will exercise reasonable care in this respect, Company shall be under not responsibility for loss or damage due to the character, condition or use of foundations, walls, or other structures not erected by Company or resulting from the excavation in proximity thereto, or for damage resulting from concealed piping, wiring, fixtures, or other equipment or condition of water pressure. All shoring or protection of foundation, walls or other structures subject to being disturbed by any excavation required hereunder shall be the responsibility of Customer. Customer shall have all things in readiness for installation including, without limitation, structure to



support the sprinkler system and related equipment (including tanks), other materials, floor or suitable working base, connections and facilities for erection at the time the materials are delivered. In the event Customer fails to have all things in readiness at the time scheduled for receipt of materials, Customer shall reimburse Company for all expenses caused by such failure. Failure to make areas available to Company during performance in accordance with schedules that are the basis for Company's proposal shall be considered a failure to have things in readiness in accordance with the terms of this Agreement.

**12. Confined Space.** If access to confined space by Company is required for the performance of Services, Services shall be scheduled and performed in accordance with Company's then-current hourly rate.

**13. Hazardous Materials.** Customer represents that, except to the extent that Company has been given written notice of the following hazards prior to the execution of this Agreement, to the best of Customer's knowledge there is no:

- Space in which work must be performed that, because of its construction, location, contents or work activity therein, accumulation of a hazardous gas, vapor, dust or fume or the creation of an oxygen-deficient atmosphere may occur,
- "permit confined space," as defined by OSHA for work performed by Company in the United States,
- risk of infectious disease,
- need for air monitoring, respiratory protection, or other medical risk,
- asbestos, asbestos-containing material, formaldehyde or other potentially toxic or otherwise hazardous material contained in or on the surface of the floors, walls, ceilings, insulation or other structural components of the area of any building where work is required to be performed under this Agreement.

All of the above are hereinafter referred to as "Hazardous Conditions". Company shall have the right to rely on the representations listed above. If hazardous conditions are encountered by Company during the course of Company's work, the discovery of such materials shall constitute an event beyond Company's control and Company shall have no obligation to further perform in the area where the hazardous conditions exist until the area has been made safe by Customer as certified in writing by an independent testing agency, and Customer shall pay disruption expenses and re-mobilization expenses as determined by Company. This Agreement does not provide for the cost of testing involving a discharge or release, capture, containment, transport, removal, or disposal (collectively, the "Discharge Services") of any hazardous waste materials, hazardous materials, or firefighting materials including without limitation firefighting foam encountered in and/or discharged from any of the Covered System(s) and/or during performance of the Services. Said materials shall at all times remain the responsibility and property of

Customer. Customer shall be responsible for any Discharge Services associated with such materials, including all discharged firefighting foam in accordance with all applicable law. Company shall not be responsible for the testing, removal or disposal of such hazardous materials. Customer shall indemnify and hold Company harmless from and against any and all claims, demands and/or damages arising in whole or in part from the use of or any Discharge Services associated with any hazardous waste, hazardous materials, or firefighting materials including without limitation firefighting foam encountered or discharged from any of the Covered System(s) and/or during performance of the Services.

**14. COVID-19 Vaccination.** Company expressly disclaims any requirement, understanding or agreement, express or implied, included directly or incorporated by reference, in any Customer purchase order, solicitation, notice or otherwise, that any of Company's personnel be vaccinated against Covid-19 under any federal, state/provincial or local law, regulation or order applicable to government contracts or subcontracts, including, without limitation, Presidential Executive Order 14042 ("Ensuring Adequate COVID Safety Protocols for Federal Contractors") and Federal Acquisition Regulation (FAR) 52.223-99 ("Ensuring Adequate COVID Safety Protocols for Federal Contractors"). Any such requirement shall only apply to Company's personnel if and only to the extent contained in a written agreement physically signed by an authorized officer of Company.

**15. Occupational Health and Safety/OSHA Compliance.** Customer shall indemnify and hold Company harmless from and against any and all claims, demands and/or damages arising in whole or in part from the enforcement of applicable laws regarding occupational health and safety for work performed in Canada or the Occupational Safety Health Act for work performed by Company in the United States. (and any amendments or changes thereto) unless said claims, demands or damages are a direct result of causes within the exclusive control of Company.

**16. Interferences.** Customer shall be responsible to coordinate the work of other trades (including but not limited to ducting, piping, and electrical) and for and additional costs incurred by Company arising out of interferences to Company's work caused by other trades.

**17. Modifications and Substitutions.** Company reserves the right to modify materials, including substituting materials of later design, providing that such modifications or substitutions will not materially affect the performance of the Covered System(s).

**18. Changes, Alterations, Additions.** Changes, alterations and additions to the Scope of Work, plans,

specifications or construction schedule shall be invalid unless approved in writing by Company. Should changes be approved by Company, that increase or decrease the cost of the work to Company, the parties shall agree, in writing, to the change in price prior to performance of any work. However, if no agreement is reached prior to the time for performance of said work, and Company elects to perform said work so as to avoid delays, then Company's estimate as to the value of said work shall be deemed accepted by Customer. In addition, Customer shall pay for all extra work requested by Customer or made necessary because of incompleteness or inaccuracy of plans or other information submitted by Customer with respect to the location, type of occupancy, or other details of the work to be performed. In the event the layout of Customer's facilities has been altered, or is altered by Customer prior to the completion of the Work, Customer shall advise Company, and prices, delivery and completion dates shall be changed by Company as may be required.

**19. Commodities Availability.** Company shall not be responsible for failure to provide services, deliver products, or otherwise perform work required by this Agreement due to lack of available steel products or products made from plastics or other commodities. In the event Company is unable, after reasonable commercial efforts, to acquire and provide steel products, or products made from plastics or other commodities, if required to perform work required by this Agreement, Customer hereby agrees that Company may terminate the Agreement, or the relevant portion of the Agreement, at no additional cost and without penalty. Customer agrees to pay Company in full for all work performed up to the time of any such termination.

**20. Project Claims.** Any claim of failure to perform against Company arising hereunder shall be deemed waived unless received by Company, in writing specifically setting forth the basis for such claim, within ten (10) days after such claims arises.

**21. Back charges.** No charges shall be levied against Company unless seventy-two (72) hours prior written notice is given to Company to correct any alleged deficiencies which are alleged to necessitate such charges and unless such alleged deficiencies are solely and directly caused by Company.

**22. System Equipment.** The purchase of equipment or peripheral devices (including but not limited to smoke detectors, passive infrared detectors, card



readers, sprinkler system components, extinguishers and hoses) from Company shall be subject to the terms and conditions of this Agreement. If, in Company's sole judgment, any peripheral device or other system equipment, which is attached to the Covered System(s), whether provided by Company or a third party, interferes with the proper operation of the Covered System(s), Customer shall remove or replace such device or equipment promptly upon notice from Company. Failure of Customer to remove or replace the device shall constitute a material breach of this Agreement. If Customer adds any third party device or equipment to the Covered System(s), Company shall not be responsible for any damage to or failure of the Covered System(s) caused in whole or in part by such device or equipment.

**22. Reports.** Where inspection and/or test services are selected, such inspection and/or test shall be completed on Company's then current Report form, which shall be given to Customer, and, where applicable, Company may submit a copy thereof to the local authority having jurisdiction. The Report and recommendations by Company are only advisory in nature and are intended to assist Customer in reducing the risk of loss to property by indicating obvious defects or impairments noted to the system and equipment inspected and/or tested. They are not intended to imply that no other defects or hazards exist or that all aspects of the Covered System(s), equipment, and components are under control at the time of inspection. Final responsibility for the condition and operation of the Covered System(s) and equipment and components lies with Customer.

**23. Limited Warranty.** Subject to the limitations below, Company warrants any equipment (as distinguished from the Software) installed pursuant to this Agreement to be free from defects in material and workmanship under normal use for a period of one (1) year from the date of first beneficial use or all or any part of the Covered System(s) or 18 months after Equipment shipments, whichever is earlier, provided however, that Company's sole liability, and Customer's sole remedy, under this limited warranty shall be limited to the repair or replacement of the Equipment or any part thereof, which Company determines is defective, at Company's sole option and subject to the availability of service personnel and parts, as determined by Company. Company warrants expendable items, including, but not limited to, video and print heads, television camera tubes, video

monitor displays tubes, batteries and certain other products in accordance with the applicable manufacturer's warranty. Company does not warrant devices designed to fail in protecting the System, such as, but not limited to, fuses and circuit breakers. Company warrants that any Company software described in this Agreement, as well as software contained in or sold as part of any Equipment described in this Agreement, will reasonably conform to its published specifications in effect at the time of delivery and for ninety (90) days after delivery. However, Customer agrees and acknowledges that the software may have inherent defects because of its complexity. Company's sole obligation with respect to software, and Customer's sole remedy, shall be to make available published modifications, designed to correct inherent defects, which become available during the warranty period. If Repair Services are included in this Agreement, Company warrants that its workmanship and material for repairs made pursuant to this Agreement will be free from defects for a period of ninety (90) days from the date of furnishing.

**EXCEPT AS EXPRESSLY SET FORTH HEREIN, COMPANY DISCLAIMS ALL WARRANTIES, EXPRESS OR IMPLIED, INCLUDING BUT NOT LIMITED TO ANY IMPLIED WARRANTIES OF MERCHANTABILITY OR FITNESS FOR A PARTICULAR PURPOSE WITH RESPECT TO THE SERVICES PERFORMED OR THE PRODUCTS, SYSTEMS OR EQUIPMENT, IF ANY, SUPPORTED HEREUNDER.** Warranty service will be performed during Company's normal working hours. If Customer requests warranty service at other than normal working hours, service will be performed at Company's then current rates for after ours services. All repairs or adjustments that are or may become necessary shall be performed by and authorized representative of Company. Any repairs, adjustments or interconnections performed by Customer or any third party shall void all warranties. Company makes no and specifically disclaims all representations or warranties that the services, products, software or third party product or software will be secure from cyber threats, hacking or other similar malicious activity, or will detect the presence of, or eliminate, treat, or mitigate the spread transmission, or outbreak of any pathogen, disease, virus or other contagion, including but not limited to COVID-19.

**25. Indemnity.** Customer agrees to indemnify, hold harmless and defend Company against any and all losses, damages, costs, including expert fees and costs, and expenses including reasonable defense costs, arising from any and all third party claims for personal injury, death, property damage or economic loss, including specifically any damages resulting from the exposure of workers to Hazardous Conditions whether or not Customer pre-notifies Company of the existence of said hazardous conditions, arising in any way from any act or omission of Customer or Company relating in any way to this Agreement, including but not limited to the

Services under this Agreement, whether such claims are based upon contract, warranty, tort (including but not limited to active or passive negligence), strict liability or otherwise. Company reserves the right to select counsel to represent it in any such action.

**26. Insurance.** Customer shall name Company, its officers, employees, agents, subcontractors, suppliers, and representatives as additional insureds on Customer's general liability and auto liability policies.

**27. Termination.** Any termination under the terms of this Agreement shall be made in writing. In the event Customer terminates this Agreement prior to completion for any reason not arising solely from Company's performance or failure to perform, Customer understands and agrees that Company will incur costs of administration and preparation that are difficult to estimate or determine. Accordingly, should Customer terminate this Agreement as described above, Customer agrees to pay all charges incurred for products and equipment installed and services performed, and in addition pay an amount equal to twenty (20%) percent of the price of products and equipment not yet delivered and Services not yet performed, return all products and equipment delivered and pay a restocking fee of twenty (20%) percent the price of products or equipment returned. Company may terminate this Agreement immediately at its sole discretion upon the occurrence of any Event of Default as hereinafter defined. Company may also terminate this Agreement at its sole discretion upon notice to Customer if Company's performance of its obligations under this Agreement becomes impracticable due to obsolescence of equipment at Customer's premises or unavailability of parts.

**28. Default.** An Event of Default shall be (a) failure of Customer to pay any amount when due and payable, (b) abuse of the System or the Equipment, (c) dissolution, termination, discontinuance, insolvency or business failure of Customer. Upon the occurrence of an Event of Default, Company may pursue one or more of the following remedies: (i) discontinue furnishing Services and delivering Equipment, (ii) by written notice to Customer declare the balance of unpaid amounts due and to become due under this Agreement to be immediately due and payable; (iii) receive immediate possession of any Equipment for which Customer has not paid; (iv) proceed at law or equity to enforce performance by Customer or



recover damages for breach of this Agreement, and (v) recover all costs and expenses, including without limitation reasonable attorneys' fees, in connection with enforcing or attempting to enforce this Agreement.

**29. Exclusions.** Unless expressly included in the Scope of Work, this Agreement expressly excludes, without limitation, testing inspection and repair of duct detectors, beam detectors, and UV/IR equipment; provision of fire watches; clearing of ice blockage; draining of improperly pitched piping; replacement of batteries; recharging of chemical suppression systems; reloading of, upgrading, and maintaining computer software; system upgrades and the replacement of obsolete systems, equipment, components or parts; making repairs or replacements necessitated by reason of negligence or misuse of components or equipment or changes to Customer's premises, vandalism, corrosion (including but not limited to micro-bacterially induced corrosion ("MIC")), power failure, current fluctuation, failure due to non-Company installation, lightning, electrical storm, or other severe weather, water, accident, fire, acts of God or any other cause external to the Covered System(s). Repair Services provided pursuant to this Agreement do not cover and specifically excludes system upgrades and the replacement of obsolete systems, equipment, components or parts. All such services may be provided by Company at Company's sole discretion at an additional charge. If Emergency Services are expressly included in the scope of work section, the Agreement price does not include travel expenses.

**30. No Option to Solicit.** Customer shall not, directly or indirectly, on its own behalf or on behalf of any other person, business, corporation or entity, solicit or employ any Company employee, or induce any Company employee to leave his or her employment, for a period of two years after termination of this Agreement.

**31. Force Majeure; Delays.** Company shall not be liable, nor in breach or default of its obligations under this Agreement, for delays, interruption, failure to render services, or any other failure by Company to perform an obligation under this Agreement, where such delay, interruption or failure is caused, in whole or in part, directly or indirectly, by a Force Majeure Event. A "Force Majeure Event" is a condition or event that is beyond the reasonable control of Company, whether foreseeable or unforeseeable,

including, without limitation, acts of God, severe weather (including but not limited to hurricanes, tornados, severe snowstorms or severe rainstorms), wildfires, floods, earthquakes, seismic disturbances, or other natural disasters, acts or omissions of any governmental authority (including change of any applicable law or regulation), epidemics, pandemics, disease, viruses, quarantines, or other public health risks and/or responses thereto, condemnation, strikes, lock-outs, labor disputes, an increase of 5% or more in tariffs or other excise taxes for materials to be used on the project, fires, explosions or other casualties, thefts, vandalism, civil disturbances, insurrection, mob violence, riots, war or other armed conflict (or the serious threat of same), acts of terrorism, electrical power outages, interruptions or degradations in telecommunications, computer, network, or electronic communications systems, data breach, cyber-attacks, ransomware, unavailability or shortage of parts, materials, supplies, or transportation, or any other cause or casualty beyond the reasonable control of Company. If Company's performance of the work is delayed, impacted, or prevented by a Force Majeure Event or its continued effects, Company shall be excused from performance under the Agreement. Without limiting the generality of the foregoing, if Company is delayed in achieving one or more of the scheduled milestones set forth in the Agreement due to a Force Majeure Event, Company will be entitled to extend the relevant completion date by the amount of time that Company was delayed as a result of the Force Majeure Event, plus such additional time as may be reasonably necessary to overcome the effect of the delay. To the extent that the Force Majeure Event directly or indirectly increases Company's cost to perform the services, Customer is obligated to reimburse Company for such increased costs, including, without limitation, costs incurred by Company for additional labor, inventory storage, expedited shipping fees, trailer and equipment rental fees, subcontractor fees or other costs and expenses incurred by Company in connection with the Force Majeure Event.

**32. One-Year Claims Limitation; Choice of Law.**

For Customers located in the United States, the laws of Wisconsin shall govern the validity, enforceability, and interpretation of this Agreement, without regard to conflicts of law. For customers located in Canada, this agreement shall be governed by and be construed in accordance with the laws of Ontario. The parties

agree that any disputes arising under this Agreement shall be determined exclusively by the Ontario courts and that no action or legal proceedings of any nature shall be filed or commenced in any other court pertaining to any dispute arising out of or in relation to this Agreement. The parties also hereby waive any objection to the exclusive jurisdiction of the Ontario courts, including any objection based on *forum non conveniens*. No claim or cause of action, whether known or unknown, shall be brought against Company more than one year after the claim first arose. Except as provided for herein, Company's claims must also be brought within one year. Claims not subject to the one-year limitation include claims for unpaid: (a) contract amounts, (b) change order amounts (approved or requested) and (c) delays and/or work inefficiencies.

**33. Assignment.** Customer may not assign this Agreement without Company's prior written consent. Company may assign this Agreement to an affiliate without obtaining Customer's consent.

**34. Entire Agreement.** The parties intend this Agreement, together with any attachments or Riders (collectively the "Agreement") to be the final, complete and exclusive expression of their Agreement and the terms and conditions thereof. This Agreement supersedes all prior representations, understandings or agreements between the parties, written or oral, and shall constitute the sole terms and conditions of sale for all equipment and services. No waiver, change, or modification of any terms or conditions of this Agreement shall be binding on Company unless made in writing and signed by an Authorized Representative of Company.

**35. Severability.** If any provision of this Agreement is held by any court or other competent authority to be void or unenforceable in whole or in part, this Agreement will continue to be valid as to the other provisions and the remainder of the affected provision.

**36. Legal Fees.** Company shall be entitled to recover from the customer all reasonable legal fees incurred in connection with Company enforcing the terms and conditions of this Agreement.

**37. Software and Digital Services.** Use, implementation, and deployment of the software and hosted software products ("Software") offered under these terms shall be subject to, and governed by, Company's standard terms for such Software and



Software related professional services in effect from time to time at <https://www.johnsoncontrols.com/techterms> (collectively, the "Software Terms"). Applicable Software Terms are incorporated herein by this reference. Other than the right to use the Software as set forth in the Software Terms, Company and its licensors reserve all right, title, and interest (including all intellectual property rights) in and to the Software and improvements to the Software. The Software that is licensed hereunder is licensed subject to the Software Terms and not sold. If there is a conflict between the other terms herein and the Software Terms, the Software Terms shall take precedence and govern with respect to rights and responsibilities relating to the Software, its implementation and deployment and any improvements thereto. Notwithstanding any other provisions of this Agreement and unless otherwise agreed to by the parties in writing, the following terms apply to Software that is provided to Customer on a subscription basis (i.e., a time limited license or use right), (each a "Software Subscription"): Each Software Subscription provided hereunder will commence on the date the initial credentials for the Software are made available (the "Subscription Start Date") and will continue in effect until the expiration of the subscription term noted herein. At the expiration of the Software Subscription, such Software Subscription will automatically renew for consecutive one (1) year terms (each a "Renewal Subscription Term"), unless either party provides the other party with a notice of non-renewal at least ninety (90) days prior to the expiration of the then-current term. To the extent permitted by applicable law, Software Subscriptions purchases are non-cancelable and the sums paid nonrefundable. Fees for Software Subscriptions shall be paid annually in advance, invoiced on the Subscription Start Date and each subsequent anniversary thereof. Unless otherwise agreed by the parties in writing, the subscription fee for each Renewal Subscription Term will be priced at JCI's then-applicable list price for that Software offering. Any use of Software that exceeds the scope, metrics or volume set forth in this Agreement will be subject to additional fees based on the date such excess use began.

**38. Electronic Media. Electronic Media. Either party may scan, fax, email, image, or otherwise convert this Agreement into an electronic format of any type or form, now known or developed in**

**the future. Any unaltered or unadulterated copy of this Agreement produced from such an electronic format will be legally binding upon the parties and equivalent to the original for all purposes, including litigation. JCI may rely upon Customer's assent to the terms and conditions of this Agreement, if Customer has signed this Agreement or demonstrated its intent to be bound whether by electronic signature or otherwise.**

**39. Lien Legislation.** Notwithstanding anything to the contrary contained herein, the terms of this Agreement shall be subject to the lien legislation applicable to the location where the work will be performed, and, in the event of conflict, the applicable lien legislation shall prevail.

**40. Privacy. Company as :** Where Company factually acts as Processor of Personal Data on behalf of Customer (as such terms are defined in the DPA) the terms at [www.johnsoncontrols.com/dpa](http://www.johnsoncontrols.com/dpa) ("DPA") shall apply. **Company as :** Company will collect, process and transfer certain personal data of Customer and its personnel related to the business relationship between it and Customer (for example names, email addresses, telephone numbers) as controller and in accordance with Company's Privacy Notice at <https://www.johnsoncontrols.com/privacy>. Customer acknowledges Company's Privacy Notice and strictly to the extent consent is mandatorily required under applicable law, Customer consents to such collection, processing and transfer. To the extent consent to such collection, processing and transfer by Company is mandatorily required from Customer's personnel under applicable law, Customer warrants and represents that it has obtained such consent.

**41. License Information (Security System Customers):** **AL Alabama Electronic Security Board of Licensure 7956 Vaughn Road, Pmb 392, Montgomery, Alabama 36116 (334) 264-9388: AR Regulated by: Arkansas Board of Private Investigators And Private Security Agencies, #1 State Police Plaza Drive, Little Rock 72209 (501)618-8600: CA Alarm company operators are licensed and regulated by the Bureau of Security and Investigative Services, Department of Consumer Affairs, Sacramento, CA, 95814. Upon completion of the installation of the alarm system, the alarm company shall thoroughly instruct the purchaser in the proper use of the alarm system. Failure by the licensee, without legal excuse, to substantially commence work within 20 days from**

**the approximate date specified in the agreement when the work will begin is a violation of the Alarm Company Act: NY Licensed by N.Y.S. Department of the State: TX Texas Commission on Private Security, 5805 N. Lamar Blvd., Austin, 78752-4422, 512-424-7710. License numbers available at [www.johnsoncontrols.com](http://www.johnsoncontrols.com) or contact your local Johnson Controls office.**

**AWARD OF BID FOR WATER AND SEWER  
CONSTRUCTION AND REPAIR MATERIALS**

**WHEREAS**, the Niagara Falls Water Board (“Water Board”) maintains an extensive system of water and sewer facilities and appurtenant structures that from time to time require repair, reconstruction, or expansion through construction; and

**WHEREAS**, Water Board staff worked with City of Niagara Falls Purchasing to develop a list of 215 different items commonly used by the Water Board for water and sewer construction and repairs, such as pipe of different materials and sizes, fittings, manhole components, catch basins, fire hydrants, etc.; and

**WHEREAS**, City of Niagara Falls Purchasing put the list of items out to bid under Bid # W2023-01 in a manner that permits the award of the bid for each item to appropriate vendors, with Item Numbers 95 - 140 to be awarded, except for Corporation Stops (Items 131 through 140), in groups to one vendor, in accordance with Paragraph 10 of the Bid Specifications, to ensure product compatibility and efficiency; and

**WHEREAS**, City of Niagara Falls Purchasing has tabulated the results and Water Board staff recommend the award of the bid for each item as set forth herein, except that there shall be no award for Bid Item Numbers 53, 102, 140, 175, and 200, for which no bid was received;

\* CONTINUED ON NEXT PAGE \*

**NOW THEREFORE BE IT**

**RESOLVED**, that the Niagara Falls Water Board awards Bid # W2023-01 for water and sewer construction and repair materials by bid item number as follows:

**TO: K & S Contractors Supply, Incorporated**

**FOR:** Item Numbers: 1-4, 6-9, 19, 28-31, 42, 57-64, 66, 67, 69, 70, 75-89, 95-100, 103, 105, 107, 111-114, 115 (provisionally – per Paragraph 10 of the Bid Specifications), 116-134, 136-138, 145-155

**TO: Core & Main LP**

**FOR:** Item Numbers: 5, 10-14, 20, 21, 24-27, 39-41, 43, 44, 54-56, 65, 68, 91, 101, 104, 106, 108, 110, 135, 139, 144

**TO: EJP, Incorporated**

**FOR:** Items Numbers: 32-38, 45-52, 71-74, 109, 115, 177C (Fernco), 178C (Fernco), 179-199, 201-215

**TO: Ferguson Waterworks**

**FOR:** Items Numbers: 15-18, 22, 23, 141-143, 156-158

**TO: Blair Supply Corporation**

**FOR:** Items Numbers: 90, 92-94, 104, 159-167

**TO: Kistner Concrete Products**

**FOR:** Item Number: 168 – Full Load Only

**TO: Neenah Enterprises Inc.**

**FOR:** Item Numbers: 169-174

**TO: SPK Steel Fabrication**

**FOR:** Item Numbers: 176, 177, 178 (Solid Manhole Riser Rings); and

\* CONTINUED ON NEXT PAGE \*



**IT IS FURTHER RESOLVED**, that the Executive Director hereby is authorized to execute any documents required to award the bid as indicated, and budgeted purchases may be made from the vendors awarded the bid.

*Water Board Personnel Responsible for Implementation of this Resolution:*  
 Executive Director

*Water Board Budget Line or Capital Plan Item with Funds for this Resolution:*  
 Water Construction FA.8340.0200.0419.006  
 Sewer Construction FA.8120.4900.0419.006  
 Undesignated Supplies Water FA.8340.0200.0419.599  
 Undesignated Supplies Sewer GA.8120.4900.0419.599  
 Budget/Capital Lines Supplied by: D. Williamson  
 Budget/Capital Lines Confirmed by: B. Majchrowicz

On September 25, 2023, the question of the adoption of the foregoing Resolution was duly put to a vote on roll call, which resulted as follows:

	<b>Yes</b>	<b>No</b>	<b>Abstain</b>	<b>Absent</b>
Board Member Asklar	[   ]	[   ]	[   ]	[   ]
Board Member Kimble	[   ]	[   ]	[   ]	[   ]
Board Member Larkin	[   ]	[   ]	[   ]	[   ]
Board Member Leffler	[   ]	[   ]	[   ]	[   ]
Chairman Forster	[   ]	[   ]	[   ]	[   ]

Signed By:

Vote Witnessed By:

---

Nicholas J. Forster, Chairman

---

Sean W. Costello, Secretary to Board



**TO:** Niagara Falls Water Board

**FROM:** Michael Eagler, Acting Executive Director  
Sean Costello, General Counsel and Secretary

**DATE:** September 13, 2023

**SUBJECT:** **BID #W2023-01 Water and Sewer Construction and Repair Materials**

We respectfully request you award the above referenced bid per the enclosed tally sheet as follows:

**TO:** **K & S Contractors Supply, Incorporated**  
1971 Gunnville Road  
Lancaster, New York 14086

**FOR:** Item Numbers: 1-4, 6-9, 19, 28-31, 42, 57-64, 66, 67, 69, 70, 75-89, 95-100, 103, 105, 107, 111-114, 115 (provisionally – see Paragraph 10 of the Bid Specifications), 116-134, 136-138, 145-155

**TO:** **Core & Main LP**  
650 West Avenue  
Lockport, New York 14094

**FOR:** Item Numbers: 5, 10-14, 20, 21, 24-27, 39-41, 43, 44, 54-56, 65, 68, 91, 101, 104, 106, 108, 110, 135, 139, 144

**TO:** **EJP, Incorporated**  
200 Lake Avenue  
Blasdell, New York 14219

**FOR:** Items Numbers: 32-38, 45-52, 71-74, 109, 115, **177C (Fernco), 178C (Fernco)**, 179-199, 201-215

**TO:** **Ferguson Waterworks**  
6040 Drott Drive  
E. Syracuse, New York 13057

**FOR:** Item Number: 15-18, 22, 23, 141-143, 156-158

**ASKLAR** \_\_\_\_ **KIMBLE** \_\_\_\_ **LARKIN** \_\_\_\_ **LEFFLER** \_\_\_\_ **FORSTER** \_\_\_\_

5815 Buffalo Avenue • Niagara Falls, New York 14304 • 716 283-9770 • FAX 716 283-9748

[www.nfwb.org](http://www.nfwb.org)

**TO:** **Blair Supply Corporation**  
 785 Beahan Road  
Rochester, New York 14624  
**FOR:** Item Number: 90, 92-94, 104, 159-167

**TO:** **Kistner Concrete Products**  
 8713 Read Road  
East Pembroke, New York 14056  
**FOR:** Item Number: 168 – Full Load Only

**TO:** **Neenah Enterprises Inc.**  
 2121 Brooks Avenue  
Neenah, Wisconsin 54956  
**FOR:** Item Number: 169-174

**TO:** SPK Steel Fabrication  
 340 Broad Street  
 PO Box 149  
Fitchburg, Massachusetts 01420  
**FOR:** Item Number: 176, 177, 178 (Solid Manhole Riser Rings)

Item Numbers 95 - 140 to be awarded, except for Corporation Stops (Items 131 through 140), in groups to one vendor, in accordance with Paragraph 10 of the Bid Specifications to ensure product compatibility and efficiency. The Corporation Stops are to be awarded individually by number to the lowest priced vendor as they are compatible products and therefore the lowest price should be accepted for each item.

Additionally, please note that no bids were received for Item Numbers 53, 102, 140, 175 and 200.

The Purchasing Agent certifies that all bids were solicited in accordance with Section 103 of the General Municipal Law.

**ASKLAR** \_\_\_\_\_ **KIMBLE** \_\_\_\_\_ **LARKIN** \_\_\_\_\_ **LEFFLER** \_\_\_\_\_ **FORSTER** \_\_\_\_\_

5815 Buffalo Avenue • Niagara Falls, New York 14304 • 716 283-9770 • FAX 716 283-9748

Notice that bids were to be received was advertised in the Niagara Gazette and bid requests were sent to twenty (20) vendors. Nine (9) bids were received. The above referenced vendors have submitted the lowest bids to meet the specifications for each respective item.

Funds for this expenditure are available as needed in the Outside Water budget code.

Respectfully submitted,

---

Michael Eagler  
Acting Executive Director  
Niagara Falls Water Board

---

Leeann K. Huey  
Purchasing Agent  
City of Niagara Falls

Attachment/Enclosures: Two sets of Tally Sheets

**ASKLAR**\_\_\_\_ **KIMBLE** \_\_\_\_ **LARKIN** \_\_\_\_ **LEFFLER** \_\_\_\_ **FORSTER** \_\_\_\_\_

5815 Buffalo Avenue • Niagara Falls, New York 14304 • 716 283-9770 • FAX 716 283-9748

---

[www.nfwb.org](http://www.nfwb.org)

**OFFICIAL TALLY SHEET**

**NIAGARA FALLS WATER BOARD BID #W2023-01 WATER AND SEWER CONSTRUCTION AND REPAIR MATERIALS SET 1 OF 2**

**OPENING DATE: WEDNESDAY, JULY 12, 2023 AT 10:00 AM**

Page 1 of 20

ITEM #	EST. QTY	UNIT	DESCRIPTION	UNIT PRICE	UNIT PRICE	UNIT PRICE	UNIT PRICE	UNIT PRICE
			<b>VENDOR NAME AND ADDRESS</b>					
				SPK Steel Fabrication 340 Broad St. PO Box 149 Fitchburg MA 01420	Kistner Concrete 8713 Read Road E. Pembroke NY 14056	Ferguson Waterworks 6040 Drott Drive E Syracuse NY 13057	Blair Supply Corp 785 Beahan Road Rochester NY 14624	Neenah Enterprises Inc. 2121 Brooks Ave Neenah WI 54956
			<b>STANDARD BURY FIRE HYDRANTS (MUELLER CENTURION KENNEDY GUARDIAN)</b>					
1	5	EA.	4 FT. Bury	NO BID	NO BID	NO BID	3555.00	NO BID
2	15	EA.	5 FT. Bury	NO BID	NO BID	NO BID	3725.00	NO BID
3	5	EA.	6 FT. Bury	NO BID	NO BID	NO BID	3885.00	NO BID
			<b>BREAKAWAY KITS</b>					
4	15	EA.	Breakaway Kits for Kennedy Guardian	NO BID	NO BID	NO BID	315.00	NO BID
5	15	EA.	Breakaway Kits for Mueller Centurion	NO BID	NO BID	NO BID	335.00	NO BID
			<b>CAST IRON CURB &amp; VALVE BOX PARTS, ALL SCREW TYPE VALVES AND CURB BOXES SHALL BE AS MANUFACTURED BY BIBBY-ST. CROIX FOUNDRIES INC. OR EQUIVALENT COVERS SHALL BE CAST WITH "WATER" LABEL ON TOP VALVE ROAD BOXES</b>					
6	20	EA.	Bases 14 3/8" base, 8 1/4" top, 12 3/8" high	NO BID	NO BID	<sup>2</sup> 118.87	NO BID	NO BID
7	20	EA.	Top Sections 26"	NO BID	NO BID	<sup>2</sup> 126.40	NO BID	NO BID
8	20	EA.	Top Sections 17"	NO BID	NO BID	<sup>2</sup> 84.65	NO BID	NO BID

**OFFICIAL TALLY SHEET**

**NIAGARA FALLS WATER BOARD BID #W2023-01 WATER AND SEWER CONSTRUCTION AND REPAIR MATERIALS SET 1 OF 2**

**OPENING DATE: WEDNESDAY, JULY 12, 2023 AT 10:00 AM**

Page 2 of 20

ITEM #	EST. QTY	UNIT	DESCRIPTION	UNIT PRICE	UNIT PRICE	UNIT PRICE	UNIT PRICE	UNIT PRICE
			<b>VENDOR NAME AND ADDRESS</b>	SPK Steel Fabrication 340 Broad St. PO Box 149 Fitchburg MA 01420	Kistner Concrete 8713 Read Road E. Pembroke NY 14056	Ferguson Waterworks 6040 Drott Drive E Syracuse NY 13057	Blair Supply Corp 785 Beahan Road Rochester NY 14624	Neenah Enterprises Inc. 2121 Brooks Ave Neenah WI 54956
9	20	EA.	Bottom Sections 30"	NO BID	NO BID	<sup>2</sup> 107.66	NO BID	NO BID
10	20	EA.	Bottom Sections 24"	NO BID	NO BID	<sup>2</sup> 88.30	NO BID	NO BID
11	20	EA.	Bottom Sections 16"	NO BID	NO BID	<sup>2</sup> 68.10	NO BID	NO BID
12	30	EA.	Shaft Extensions 26"	NO BID	NO BID	<sup>2</sup> 107.65	NO BID	NO BID
13	30	EA.	Shaft Extensions 16"	NO BID	NO BID	<sup>2</sup> 76.90	NO BID	NO BID
			<b>VALVE BOX HEIGHT ADAPTERS (For Adjusting Boxes to Pavement Level)</b>					
14	50	EA.	Slide Type: Adjustment Range 2-1/2" to 8" 10-3/4" Height; 4-3/8" inner diameter	NO BID	NO BID	<sup>2</sup> 60.83	NO BID	NO BID
15	50	EA.	Screw-Type, Adjustment Range 2-1/2" to 8" 16-1/2" Height; 5-1/4" inner diameter	NO BID	NO BID	<sup>2</sup> 95.18	NO BID	NO BID
16	50	EA.	Valve Box Riser V829 Fixed 5-1/4 x 1	NO BID	NO BID	<sup>2</sup> 21.83	NO BID	NO BID
17	50	EA.	Valve Box Riser V830 Fixed 5-1/4 x 1-1/2	NO BID	NO BID	<sup>2</sup> 24.42	NO BID	NO BID
18	50	EA.	Valve Box Riser V831 Fixed 5-1/4 x 2	NO BID	NO BID	<sup>2</sup> 28.07	NO BID	NO BID
			<b>VALVE BOX REGULATOR COVERS 5-1/4"</b>					
19	40	EA.	(MARKED WATER)	NO BID	NO BID	<sup>2</sup> 29.80	NO BID	NO BID

**OFFICIAL TALLY SHEET**

**NIAGARA FALLS WATER BOARD BID #W2023-01 WATER AND SEWER CONSTRUCTION AND REPAIR MATERIALS SET 1 OF 2**

**OPENING DATE: WEDNESDAY, JULY 12, 2023 AT 10:00 AM**

Page 3 of 20

ITEM #	EST. QTY	UNIT	DESCRIPTION	UNIT PRICE	UNIT PRICE	UNIT PRICE	UNIT PRICE	UNIT PRICE
<b>VENDOR NAME AND ADDRESS</b>								
				SPK Steel Fabrication 340 Broad St. PO Box 149 Fitchburg MA 01420	Kistner Concrete 8713 Read Road E. Pembroke NY 14056	Ferguson Waterworks 6040 Drott Drive E Syracuse NY 13057	Blair Supply Corp 785 Beahan Road Rochester NY 14624	Neenah Enterprises Inc. 2121 Brooks Ave Neenah WI 54956
<b>CURB BOXES</b>								
20	25	EA.	Bottom 33"	NO BID	NO BID	<sup>2</sup> 70.10	NO BID	NO BID
21	25	EA.	Bottom 24"	NO BID	NO BID	<sup>2</sup> 49.45	NO BID	NO BID
22	25	EA.	Top Section w/Cover 16"	NO BID	NO BID	<sup>2</sup> 63.89	NO BID	NO BID
23	25	EA.	Top Section w/Cover 24"	NO BID	NO BID	<sup>2</sup> 72.53	NO BID	NO BID
24	25	EA.	Extension 9"	NO BID	NO BID	<sup>2</sup> 32.75	NO BID	NO BID
25	25	EA.	Extension 16"	NO BID	NO BID	<sup>2</sup> 40.97	NO BID	NO BID
26	50	EA.	Old Style Repair Lid (Outside Lip)	NO BID	NO BID	<sup>2</sup> 40.75	NO BID	NO BID
27	50	EA.	New Style Repair Lid (Inside Up)	NO BID	NO BID	<sup>2</sup> 40.75	NO BID	NO BID
<b>CAST IRON VALVE ROAD BOX RISERS</b>								
28	30	EA.	1"	NO BID	NO BID	<sup>2</sup> 21.83	NO BID	NO BID
29	15	EA.	2"	NO BID	NO BID	<sup>2</sup> 28.07	NO BID	NO BID
30	10	EA.	4"	NO BID	NO BID	<sup>2</sup> 53.13	NO BID	NO BID
31	10	EA.	6"	NO BID	NO BID	<sup>2</sup> 86.05	NO BID	NO BID

**OFFICIAL TALLY SHEET**

**NIAGARA FALLS WATER BOARD BID #W2023-01 WATER AND SEWER CONSTRUCTION AND REPAIR MATERIALS SET 1 OF 2**

**OPENING DATE: WEDNESDAY, JULY 12, 2023 AT 10:00 AM**

Page 4 of 20

ITEM #	EST. QTY	UNIT	DESCRIPTION	UNIT PRICE	UNIT PRICE	UNIT PRICE	UNIT PRICE	UNIT PRICE
			<b>VENDOR NAME AND ADDRESS</b>					
				SPK Steel Fabrication 340 Broad St. PO Box 149 Fitchburg MA 01420	Kistner Concrete 8713 Read Road E. Pembroke NY 14056	Ferguson Waterworks 6040 Drott Drive E Syracuse NY 13057	Blair Supply Corp 785 Beahan Road Rochester NY 14624	Neenah Enterprises Inc. 2121 Brooks Ave Neenah WI 54956
			<b>DUCTILE IRON PIPE – ANSI/AWWA C151/A21.51 CLASS 52 STANDARD 18’ – 20’ LENGTHS – PUSH-ON JOINT</b>					
32	95	FEET	4”	NO BID	NO BID	NO BID	NO BID	NO BID
33	190	FEET	6”	NO BID	NO BID	NO BID	NO BID	NO BID
34	95	FEET	8”	NO BID	NO BID	NO BID	NO BID	NO BID
35	95	FEET	10”	NO BID	NO BID	NO BID	NO BID	NO BID
36	120	FEET	12”	NO BID	NO BID	NO BID	NO BID	NO BID
37	40	FEET	16”	NO BID	NO BID	NO BID	NO BID	NO BID
38	120	FEET	20”	NO BID	NO BID	NO BID	NO BID	NO BID
			<b>TRANSITION COUPLINGS (DRESSER TYPE) – COMPRESSION TYPE WITH ALL ACCESSORIES TO ADAPT FROM CAST IRON TO DUCTILE IRON PIPE – CLASS 52 AWWA 151</b>					
						<sup>3</sup> Hi-Max		
39	26	EA.	4”	NO BID	NO BID	<sup>3</sup> 232.00	NO BID	NO BID
40	30	EA.	6”	NO BID	NO BID	<sup>3</sup> 307.25	NO BID	NO BID
41	14	EA.	8”	NO BID	NO BID	<sup>3</sup> 346.90	NO BID	NO BID
42	18	EA.	10”	NO BID	NO BID	<sup>3</sup> 446.25	NO BID	NO BID



**OFFICIAL TALLY SHEET**

**NIAGARA FALLS WATER BOARD BID #W2023-01 WATER AND SEWER CONSTRUCTION AND REPAIR MATERIALS SET 1 OF 2**

**OPENING DATE: WEDNESDAY, JULY 12, 2023 AT 10:00 AM**

Page 5 of 20

ITEM #	EST. QTY	UNIT	DESCRIPTION	UNIT PRICE	UNIT PRICE	UNIT PRICE	UNIT PRICE	UNIT PRICE
			VENDOR NAME AND ADDRESS					
				SPK Steel Fabrication 340 Broad St. PO Box 149 Fitchburg MA 01420	Kistner Concrete 8713 Read Road E. Pembroke NY 14056	Ferguson Waterworks 6040 Drott Drive E Syracuse NY 13057	Blair Supply Corp 785 Beahan Road Rochester NY 14624	Neenah Enterprises Inc. 2121 Brooks Ave Neenah WI 54956
			<b>TRANSITION COUPLINGS (DRESSER TYPE) – COMPRESSION TYPE WITH ALL ACCESSORIES TO ADAPT FROM CAST IRON TO DUCTILE IRON PIPE – CLASS 52 AWWA 151 (CONTINUED)</b>					
43	8	EA.	12"	NO BID	NO BID	<sup>3</sup> 526.70	NO BID	NO BID
44	10	EA.	20"	NO BID	NO BID	<sup>3</sup> 1832.00	NO BID	NO BID
			<b>PVC WATERMAIN – AWWA C900 DR-18 – PER STICK</b>					
45	6	Stick	4" x 20' Length	NO BID	NO BID	NO BID	NO BID	NO BID
46	6	Stick	6" x 20' Length	NO BID	NO BID	NO BID	NO BID	NO BID
47	4	Stick	8" x 20' Length	NO BID	NO BID	NO BID	NO BID	NO BID
48	5	Stick	10" x 20' Length	NO BID	NO BID	NO BID	NO BID	NO BID
49	5	Stick	12" x 20' Length	NO BID	NO BID	NO BID	NO BID	NO BID
50	5	Stick	16" x 20' Length	NO BID	NO BID	NO BID	NO BID	NO BID
51	5	Stick	20" x 20' Length	NO BID	NO BID	NO BID	NO BID	NO BID
52	5	Stick	24" x 20' Length	NO BID	NO BID	NO BID	NO BID	NO BID
53	5	Stick	36" x 20' Length	NO BID	NO BID	NO BID	NO BID	NO BID

**OFFICIAL TALLY SHEET**

**NIAGARA FALLS WATER BOARD BID #W2023-01 WATER AND SEWER CONSTRUCTION AND REPAIR MATERIALS SET 1 OF 2**

**OPENING DATE: WEDNESDAY, JULY 12, 2023 AT 10:00 AM**

Page 6 of 20

ITEM #	EST. QTY	UNIT	DESCRIPTION	UNIT PRICE	UNIT PRICE	UNIT PRICE	UNIT PRICE	UNIT PRICE
			VENDOR NAME AND ADDRESS	SPK Steel Fabrication 340 Broad St. PO Box 149 Fitchburg MA 01420	Kistner Concrete 8713 Read Road E. Pembroke NY 14056	Ferguson Waterworks 6040 Drott Drive E Syracuse NY 13057	Blair Supply Corp 785 Beahan Road Rochester NY 14624	Neenah Enterprises Inc. 2121 Brooks Ave Neenah WI 54956
			<b>360 DEGREE STAINLESS STEEL REPAIR CLAMPS FORD FS SERIES OR EQUAL: 18-8 TYPE 304 SS 4" TO 10" IN ONE SECTION, 12" &amp; 16" IN TWO SECTIONS, OVER 16" IN THREE SECTIONS</b>			<sup>4</sup> Smith-Blair		
54	10	EA.	4" x 12" 4.75 – 5.15	NO BID	NO BID	94.42	107.00	NO BID
55	8	EA.	4" x 12" (w/tapped 1" cc outlet)	NO BID	NO BID	120.50	128.00	NO BID
56	5	EA.	4" x 20" 4.75 – 5.15	NO BID	NO BID	158.25	201.00	NO BID
57	20	EA.	6" x 12" 6.84 – 7.24	NO BID	NO BID	114.00	119.00	NO BID
58	8	EA.	6" x 12" (w/tapped ¾" cc outlet)	NO BID	NO BID	141.00	143.00	NO BID
59	4	EA.	6" x 12" (w/tapped 1" cc outlet)	NO BID	NO BID	141.00	143.00	NO BID
60	6	EA.	6" x 20" 6.84 – 7.24	NO BID	NO BID	198.75	205.00	NO BID
61	10	EA.	8" x 12" 9.05 – 9.30	NO BID	NO BID	134.00	131.00	NO BID
62	6	EA.	8" x 12" (w/tapped ¾" cc outlet)	NO BID	NO BID	160.00	151.00	NO BID
63	6	EA.	8" x 12" (w/tapped 1" cc outlet)	NO BID	NO BID	160.00	151.00	NO BID
64	6	EA.	8" x 20" 9.05 – 9.30	NO BID	NO BID	223.50	225.00	NO BID
65	6	EA.	10" x 12-1/2" 11.04 – 11.44	NO BID	NO BID	170.90	183.00	NO BID
66	6	EA.	10" x 12-1/2" (w/tapped ¾" cc outlet)	NO BID	NO BID	197.00	205.00	NO BID

**OFFICIAL TALLY SHEET**

**NIAGARA FALLS WATER BOARD BID #W2023-01 WATER AND SEWER CONSTRUCTION AND REPAIR MATERIALS SET 1 OF 2**

**OPENING DATE: WEDNESDAY, JULY 12, 2023 AT 10:00 AM**

Page 7 of 20

ITEM #	EST. QTY	UNIT	DESCRIPTION	UNIT PRICE	UNIT PRICE	UNIT PRICE	UNIT PRICE	UNIT PRICE
			<b>VENDOR NAME AND ADDRESS</b>	SPK Steel Fabrication 340 Broad St. PO Box 149 Fitchburg MA 01420	Kistner Concrete 8713 Read Road E. Pembroke NY 14056	Ferguson Waterworks 6040 Drott Drive E Syracuse NY 13057	Blair Supply Corp 785 Beahan Road Rochester NY 14624	Neenah Enterprises Inc. 2121 Brooks Ave Neenah WI 54956
			<b>360 DEGREE STAINLESS STEEL REPAIR CLAMPS FORD FS SERIES OR EQUAL: 18-8 TYPE 304 SS 4" TO 10" IN ONE SECTION, 12" &amp; 16" IN TWO SECTIONS, OVER 16" IN THREE SECTIONS</b>					
67	6	EA.	10" x 12-1/2" (w/tapped 1" cc outlet)	NO BID	NO BID	197.00	205.00	NO BID
68	6	EA.	10" x 12-1/2" oversized 11.37 – 11.75	NO BID	NO BID	171.30	181.00	NO BID
69	6	EA.	10" x 20" Full Circle	NO BID	NO BID	272.63	270.00	NO BID
70	6	EA.	12" x 15" 13.20 – 13.50	NO BID	NO BID	235.35	225.00	NO BID
			<b>GATE VALVES – CUT – IN MJ X MJ TYPE RESILIENT SEAT (WITH ALL ACCESSORIES) BONNET STUFFING BOX AND RETAINING BOLTS, NUTS AND WASHERS TO BE STAINLESS STEEL; ALL CLOSE CLOCKWISE AWWA C509 MUELLER CO. OR EQUAL</b>					
71	6	EA.	4"	NO BID	NO BID	NO BID	NO BID	NO BID
72	6	EA.	6"	NO BID	NO BID	NO BID	NO BID	NO BID
73	6	EA.	8"	NO BID	NO BID	NO BID	NO BID	NO BID
74	4	EA.	10"	NO BID	NO BID	NO BID	NO BID	NO BID

**OFFICIAL TALLY SHEET**

**NIAGARA FALLS WATER BOARD BID #W2023-01 WATER AND SEWER CONSTRUCTION AND REPAIR MATERIALS SET 1 OF 2**

**OPENING DATE: WEDNESDAY, JULY 12, 2023 AT 10:00 AM**

Page 8 of 20

ITEM #	EST. QTY	UNIT	DESCRIPTION	UNIT PRICE	UNIT PRICE	UNIT PRICE	UNIT PRICE	UNIT PRICE
			VENDOR NAME AND ADDRESS	SPK Steel Fabrication 340 Broad St. PO Box 149 Fitchburg MA 01420	Kistner Concrete 8713 Read Road E. Pembroke NY 14056	Ferguson Waterworks 6040 Drott Drive E Syracuse NY 13057	Blair Supply Corp 785 Beahan Road Rochester NY 14624	Neenah Enterprises Inc. 2121 Brooks Ave Neenah WI 54956
			<b>BUTTERFLY VALVES – MJ X MJ (WITH ALL ACCESSORIES) ALL CLOSE CLOCKWISE – AWWA C504 – PRATT OR MUELLER</b>					
75	2	EA.	12"	NO BID	NO BID	NO BID	NO BID	NO BID
76	2	EA.	16"	NO BID	NO BID	NO BID	NO BID	NO BID
77	2	EA.	20"	NO BID	NO BID	NO BID	NO BID	NO BID
78	2	EA.	24"	NO BID	NO BID	NO BID	NO BID	NO BID
			<b>MECHANICAL JOINT ACCESSORIES PACKAGE TO INCLUDE: GLAND; RUBBER GASKET AND BOLT KITS MJ ENDS AND ACCESSORIES – ANSI/AWWA C111/21.11</b>					
79	12	EA.	4"	NO BID	NO BID	37.20	NO BID	NO BID
80	12	EA.	6"	NO BID	NO BID	49.78	NO BID	NO BID
81	12	EA.	8"	NO BID	NO BID	51.75	NO BID	NO BID
82	12	EA.	10"	NO BID	NO BID	75.90	NO BID	NO BID
83	12	EA.	12"	NO BID	NO BID	79.95	NO BID	NO BID
84	12	EA.	16"	NO BID	NO BID	138.75	NO BID	NO BID

**OFFICIAL TALLY SHEET**

**NIAGARA FALLS WATER BOARD BID #W2023-01 WATER AND SEWER CONSTRUCTION AND REPAIR MATERIALS SET 1 OF 2**

**OPENING DATE: WEDNESDAY, JULY 12, 2023 AT 10:00 AM**

Page 9 of 20

			VENDOR NAME AND ADDRESS					
				SPK Steel Fabrication 340 Broad St. PO Box 149 Fitchburg MA 01420	Kistner Concrete 8713 Read Road E. Pembroke NY 14056	Ferguson Waterworks 6040 Drott Drive E Syracuse NY 13057	Blair Supply Corp 785 Beahan Road Rochester NY 14624	Neenah Enterprises Inc. 2121 Brooks Ave Neenah WI 54956
ITEM #	EST. QTY	UNIT	DESCRIPTION	UNIT PRICE	UNIT PRICE	UNIT PRICE	UNIT PRICE	UNIT PRICE
			<b>MECHANICAL RESTRAINTS SERIES 1100 TO INCLUDE: GLAND; RUBBER GASKET AND BOLT KITS</b>			<sup>5</sup> Stargrips		
85	10	EA.	4"	NO BID	NO BID	50.95	47.00	NO BID
86	10	EA.	6"	NO BID	NO BID	65.25	65.00	NO BID
87	10	EA.	6" Series 1100X Oversize	NO BID	NO BID	98.65	67.00	NO BID
88	6	EA.	8"	NO BID	NO BID	80.25	80.00	NO BID
89	6	EA.	10"	NO BID	NO BID	113.18	115.00	NO BID
90	6	EA.	12"	NO BID	NO BID	146.50	135.00	NO BID
91	6	EA.	36"	NO BID	NO BID	1757.55	1925.00	NO BID
			<b>MEGALUG RESTRAINTS TO INCLUDE GLAND; RUBBER GASKET AND BOLT KITS</b>					
92	6	EA.	1116 Series, Ductile Iron, 16"	NO BID	NO BID	265.55	260.00	NO BID
93	6	EA.	1120 Series, Ductile Iron, 20"	NO BID	NO BID	414.83	405.00	NO BID
94	6	EA.	1124 Series, Ductile Iron, 24"	NO BID	NO BID	579.35	535.00	NO BID

**OFFICIAL TALLY SHEET**

**NIAGARA FALLS WATER BOARD BID #W2023-01 WATER AND SEWER CONSTRUCTION AND REPAIR MATERIALS SET 1 OF 2**

**OPENING DATE: WEDNESDAY, JULY 12, 2023 AT 10:00 AM**

Page 10 of 20

ITEM #	EST. QTY	UNIT	VENDOR NAME AND ADDRESS	UNIT PRICE	UNIT PRICE	UNIT PRICE	UNIT PRICE	UNIT PRICE
			SPK Steel Fabrication 340 Broad St. PO Box 149 Fitchburg MA 01420					
			Kistner Concrete 8713 Read Road E. Pembroke NY 14056					
			Ferguson Waterworks 6040 Drott Drive E Syracuse NY 13057					
			Blair Supply Corp 785 Beahan Road Rochester NY 14624					
			Neenah Enterprises Inc. 2121 Brooks Ave Neenah WI 54956					
			<b>DESCRIPTION</b>	<b>UNIT PRICE</b>	<b>UNIT PRICE</b>	<b>UNIT PRICE</b>	<b>UNIT PRICE</b>	<b>UNIT PRICE</b>
			<b>PLASTIC/BRASS/COPPER SERVICE LINE MATERIALS BUSHINGS; (MUELLER (CC) THREAD) MUELLER H-10036, FORD BBAA SERIES OR EQUAL</b>					
95	12	EA.	1" cc x 3/4" cc	NO BID	NO BID	NO BID	17.00	NO BID
96	12	EA.	1-1/2" cc x 3/4" cc	NO BID	NO BID	NO BID	46.00	NO BID
97	12	EA.	1-1/2" cc x 1" cc	NO BID	NO BID	NO BID	46.00	NO BID
98	6	EA.	2" cc x 3/4" cc	NO BID	NO BID	NO BID	75.00	NO BID
99	6	EA.	2" cc x 1" cc	NO BID	NO BID	NO BID	76.00	NO BID
100	6	EA.	2" cc x 1-1/2" cc	NO BID	NO BID	NO BID	56.00	NO BID
			<b>PLUGS: THREAD AS INDICATED MUELLER H-1003X SERIES, FORD CSP SERIES OR EQUAL</b>					
101	10	EA.	1/2" IPT	NO BID	NO BID	NO BID	NO BID	NO BID
102	10	EA.	5/8" IPT	NO BID	NO BID	NO BID	NO BID	NO BID
103	8	EA.	3/4" cc	NO BID	NO BID	NO BID	12.00	NO BID
104	4	EA.	3/4" IPT	NO BID	NO BID	NO BID	12.00	NO BID
105	4	EA.	1" cc	NO BID	NO BID	NO BID	16.00	NO BID
106	4	EA.	1" IPT	NO BID	NO BID	NO BID	16.00	NO BID

**OFFICIAL TALLY SHEET**

**NIAGARA FALLS WATER BOARD BID #W2023-01 WATER AND SEWER CONSTRUCTION AND REPAIR MATERIALS SET 1 OF 2**

**OPENING DATE: WEDNESDAY, JULY 12, 2023 AT 10:00 AM**

Page 11 of 20

ITEM #	EST. QTY	UNIT	VENDOR NAME AND ADDRESS	UNIT PRICE	UNIT PRICE	UNIT PRICE	UNIT PRICE	UNIT PRICE
			SPK Steel Fabrication 340 Broad St. PO Box 149 Fitchburg MA 01420		Kistner Concrete 8713 Read Road E. Pembroke NY 14056	Ferguson Waterworks 6040 Drott Drive E Syracuse NY 13057	Blair Supply Corp 785 Beahan Road Rochester NY 14624	Neenah Enterprises Inc. 2121 Brooks Ave Neenah WI 54956
			<b>DESCRIPTION</b>	<b>UNIT PRICE</b>	<b>UNIT PRICE</b>	<b>UNIT PRICE</b>	<b>UNIT PRICE</b>	<b>UNIT PRICE</b>
			<b>PLUGS: THREAD AS INDICATED MUELLER H-1003X SERIES, FORD CSP SERIES OR EQUAL (CONTINUED)</b>					
107	4	EA.	1-1/2" cc	NO BID	NO BID	NO BID	43.00	NO BID
108	4	EA.	1-1/2" IPT	NO BID	NO BID	NO BID	35.00	NO BID
109	4	EA.	2" cc	NO BID	NO BID	NO BID	70.00	NO BID
110	4	EA.	2" IPT	NO BID	NO BID	NO BID	66.00	NO BID
			<b>LEAD PACK COMPRESSION COUPLINGS: LEAD ONE END/COPPER OTHER END – FORD NOS. &amp; SIZE (ALL ITEMS COMPLY WITH AWWA C-800-84)</b>					
111	35	EA.	Q28-33 3/4" strong to 3/4" IPT	NO BID	NO BID	NO BID	35.00	NO BID
112	35	EA.	Q38-33 3/4" XXS to 3/4" IPT	NO BID	NO BID	NO BID	40.00	NO BID
113	30	EA.	Q-14-33 3/4" strong to 3/4" copper comp.	NO BID	NO BID	NO BID	42.00	NO BID
114	35	EA.	Q24-33 3/4" XS to 3/4" copper comp.	NO BID	NO BID	NO BID	49.00	NO BID
115	35	EA.	Q34-43 3/4" XXS to 3/4" copper	NO BID	NO BID	NO BID	73.00	NO BID
116	20	EA.	Q24-43 1" XS TO 3/4" copper	NO BID	NO BID	NO BID	75.00	NO BID
117	20	EA.	Q34-43 1" XXS to 3/4" copper	NO BID	NO BID	NO BID	73.00	NO BID
118	14	EA.	Q14-44 1" strong to 1" copper	NO BID	NO BID	NO BID	80.00	NO BID



**OFFICIAL TALLY SHEET**

**NIAGARA FALLS WATER BOARD BID #W2023-01 WATER AND SEWER CONSTRUCTION AND REPAIR MATERIALS SET 1 OF 2**

**OPENING DATE: WEDNESDAY, JULY 12, 2023 AT 10:00 AM**

Page 12 of 20

ITEM #	EST. QTY	UNIT	DESCRIPTION	UNIT PRICE	UNIT PRICE	UNIT PRICE	UNIT PRICE	UNIT PRICE
			<b>VENDOR NAME AND ADDRESS</b>					
				SPK Steel Fabrication 340 Broad St. PO Box 149 Fitchburg MA 01420	Kistner Concrete 8713 Read Road E. Pembroke NY 14056	Ferguson Waterworks 6040 Drott Drive E Syracuse NY 13057	Blair Supply Corp 785 Beahan Road Rochester NY 14624	Neenah Enterprises Inc. 2121 Brooks Ave Neenah WI 54956
			<b>LEAD PACK COMPRESSION COUPLINGS: LEAD ONE END/COPPER OTHER END – FORD NOS. &amp; SIZE (ALL ITEMS COMPLY WITH AWWA C-800-84) (CONTINUED)</b>					
119	6	EA.	Q24-44 1" XS to 1" copper	NO BID	NO BID	NO BID	77.00	NO BID
120	12	EA.	Q34-44 1" XXS to 1" copper	NO BID	NO BID	NO BID	71.00	NO BID
121	10	EA.	Q24-66 1-1/2" XS to 1-1/2" copper	NO BID	NO BID	NO BID	126.00	NO BID
122	10	EA.	Q24-77 2 XS to 2" copper	NO BID	NO BID	NO BID	202.00	NO BID
			<b>ADAPTERS – ALL COMPRESSION:</b>					
123	50	EA.	¾" Male H-15-428	NO BID	NO BID	NO BID	NO BID	NO BID
124	50	EA.	¾" Female H-15-451	NO BID	NO BID	NO BID	NO BID	NO BID
125	30	EA.	1" Male IPT to 1" Copper Compression	NO BID	NO BID	NO BID	NO BID	NO BID
126	30	EA.	1" Female IPT to 1" Copper Compression	NO BID	NO BID	NO BID	NO BID	NO BID
127	8	EA.	1-1/2" Male IPT to 1-1/2" Copper Compression	NO BID	NO BID	NO BID	NO BID	NO BID
128	8	EA.	1-1/2" Female IPT to 1-1/2" Copper Compression	NO BID	NO BID	NO BID	NO BID	NO BID
129	8	EA.	2" Female IPT H-15-451 to 2" Copper	NO BID	NO BID	NO BID	NO BID	NO BID
130	8	EA.	2" Male IPT H-15-428	NO BID	NO BID	NO BID	NO BID	NO BID

**OFFICIAL TALLY SHEET**

**NIAGARA FALLS WATER BOARD BID #W2023-01 WATER AND SEWER CONSTRUCTION AND REPAIR MATERIALS SET 1 OF 2**

**OPENING DATE: WEDNESDAY, JULY 12, 2023 AT 10:00 AM**

Page 13 of 20

			VENDOR NAME AND ADDRESS					
				SPK Steel Fabrication 340 Broad St. PO Box 149 Fitchburg MA 01420	Kistner Concrete 8713 Read Road E. Pembroke NY 14056	Ferguson Waterworks 6040 Drott Drive E Syracuse NY 13057	Blair Supply Corp 785 Beahan Road Rochester NY 14624	Neenah Enterprises Inc. 2121 Brooks Ave Neenah WI 54956
ITEM #	EST. QTY	UNIT	DESCRIPTION	UNIT PRICE	UNIT PRICE	UNIT PRICE	UNIT PRICE	UNIT PRICE
			<b>CORPORATION STOPS (Ford or Mueller Equivalent) FORD NOS. &amp; SIZE</b>					
131	12	EA.	F600-L04-33S ¾" Copper Corp. w/swivel – 90 degree compression	NO BID	NO BID	NO BID	NO BID	NO BID
132	50	EA.	F600-L04-44S 1" Copper Corp. w/swivel – 90 degree compression	NO BID	NO BID	NO BID	NO BID	NO BID
133	12	EA.	F700-L0445 1" Iron pip w/swivel – 90 degree compression	NO BID	NO BID	NO BID	NO BID	NO BID
134	4	EA.	H-15-071-L04-66 1-1/2" Copper Corp. w/swivel 90 degree compression	NO BID	NO BID	NO BID	NO BID	NO BID
135	4	EA.	H-15-071-L04-77 2" Copper Corp. w/swivel – 90 degree compression	NO BID	NO BID	NO BID	NO BID	NO BID
136	5	EA.	2" FB 800 AWWA Thread	NO BID	NO BID	NO BID	NO BID	NO BID
137	12	EA.	¾" 90 Degree Angle Meter Coupling L-38-23	NO BID	NO BID	NO BID	NO BID	NO BID
138	10	EA.	1" 90 Degree Angle Meter Coupling L-38-44	NO BID	NO BID	NO BID	NO BID	NO BID
139	6	EA.	1" IPT Female Cap	NO BID	NO BID	NO BID	NO BID	NO BID
140	6	EA.	¾" IPT Inlet w/1" Male IPT Outlet	NO BID	NO BID	NO BID	NO BID	NO BID
			<b>COPPER TUBING – TYPE K</b>					
141	10	EA.	60 Foot Rolls – ¾"	NO BID	NO BID	351.00	NO BID	NO BID
142	5	EA.	60 Foot Rolls – 1"	NO BID	NO BID	465.60	NO BID	NO BID
143	4	EA.	60 Foot Rolls – 1-1/2"	NO BID	NO BID	748.80	NO BID	NO BID
144	4	EA.	60 Foot Rolls – 2"	NO BID	NO BID	1160.40	NO BID	NO BID

**OFFICIAL TALLY SHEET**

**NIAGARA FALLS WATER BOARD BID #W2023-01 WATER AND SEWER CONSTRUCTION AND REPAIR MATERIALS SET 1 OF 2**

**OPENING DATE: WEDNESDAY, JULY 12, 2023 AT 10:00 AM**

Page 14 of 20

ITEM #	EST. QTY	UNIT	DESCRIPTION	UNIT PRICE	UNIT PRICE	UNIT PRICE	UNIT PRICE	UNIT PRICE
			<b>VENDOR NAME AND ADDRESS</b>					
				SPK Steel Fabrication 340 Broad St. PO Box 149 Fitchburg MA 01420	Kistner Concrete 8713 Read Road E. Pembroke NY 14056	Ferguson Waterworks 6040 Drott Drive E Syracuse NY 13057	Blair Supply Corp 785 Beahan Road Rochester NY 14624	Neenah Enterprises Inc. 2121 Brooks Ave Neenah WI 54956
			<b>DESCRIPTION</b>					
			<b>CURB STOPS (Ford or Mueller Equivalent) FORD NOS. &amp; SIZE</b>					
145	16	EA.	B44-333 ¾" Copper	NO BID	NO BID	NO BID	85.00	NO BID
146	25	EA.	B11-333 ¾" Reg. IPTHD	NO BID	NO BID	NO BID	64.00	NO BID
147	8	EA.	B44-444 1" Copper	NO BID	NO BID	NO BID	125.00	NO BID
148	8	EA.	B11-444 1" Reg IPTHD	NO BID	NO BID	NO BID	101.00	NO BID
149	6	EA.	B44-666 1-1/2" Copper	NO BID	NO BID	NO BID	303.00	NO BID
150	44	EA.	B44-777 2" Copper	NO BID	NO BID	NO BID	425.00	NO BID
151	5	EA.	B11-777 2" Reg IPTHD	NO BID	NO BID	NO BID	307.00	NO BID
152	20	EA.	Compression Coupling for ¾" Copper to ¾" Copper	NO BID	NO BID	NO BID	26.00	NO BID
153	10	EA.	Compression Coupling 1" Copper to 1" Copper	NO BID	NO BID	NO BID	30.00	NO BID
154	6	EA.	Compression Coupling 1-1/2" Copper to 1-1/2" Copper	NO BID	NO BID	NO BID	100.00	NO BID
155	4	EA.	Compression Coupling 2" Copper to 2" Copper	NO BID	NO BID	NO BID	135.00	NO BID

**OFFICIAL TALLY SHEET**

**NIAGARA FALLS WATER BOARD BID #W2023-01 WATER AND SEWER CONSTRUCTION AND REPAIR MATERIALS SET 1 OF 2**

**OPENING DATE: WEDNESDAY, JULY 12, 2023 AT 10:00 AM**

Page 15 of 20

			VENDOR NAME AND ADDRESS					
ITEM #	EST. QTY	UNIT	DESCRIPTION	UNIT PRICE	UNIT PRICE	UNIT PRICE	UNIT PRICE	UNIT PRICE
				SPK Steel Fabrication 340 Broad St. PO Box 149 Fitchburg MA 01420	Kistner Concrete 8713 Read Road E. Pembroke NY 14056	Ferguson Waterworks 6040 Drott Drive E Syracuse NY 13057	Blair Supply Corp 785 Beahan Road Rochester NY 14624	Neenah Enterprises Inc. 2121 Brooks Ave Neenah WI 54956
			<b>MECHANICAL JOINTS, SHORT BODY (COMPACT) WITH FLUOROCARBON COATING</b>			<sup>6</sup> Blue Bolt		
156	10	EA.	16"	NO BID	NO BID	88.00	NO BID	NO BID
157	10	EA.	20"	NO BID	NO BID	101.25	NO BID	NO BID
158	10	EA.	24"	NO BID	NO BID	144.00	NO BID	NO BID
			<b>HYMAX COUPLINGS</b>					
159	20	EA.	4"	NO BID	NO BID	232.00	219.00	NO BID
160	50	EA.	6"	NO BID	NO BID	307.25	290.00	NO BID
161	20	EA.	8"	NO BID	NO BID	346.90	328.00	NO BID
162	10	EA.	10"	NO BID	NO BID	446.25	422.00	NO BID
163	6	EA.	12"	NO BID	NO BID	526.70	495.00	NO BID
164	8	EA.	16" (860-56-0434-16P)	NO BID	NO BID	1442.70	1360.00	NO BID
165	6	EA.	20" (860-56-0540-16P)	NO BID	NO BID	1832.00	1725.00	NO BID
166	6	EA.	24" (860-56-0624-16P)	NO BID	NO BID	1951.80	1840.00	NO BID
167	2	EA.	36"	NO BID	NO BID	3880.00	3690.00	NO BID

**OFFICIAL TALLY SHEET**

**NIAGARA FALLS WATER BOARD BID #W2023-01 WATER AND SEWER CONSTRUCTION AND REPAIR MATERIALS SET 1 OF 2**

**OPENING DATE: WEDNESDAY, JULY 12, 2023 AT 10:00 AM**

Page 16 of 20

ITEM #	EST. QTY	UNIT	DESCRIPTION	UNIT PRICE	UNIT PRICE	UNIT PRICE	UNIT PRICE	UNIT PRICE
			<b>VENDOR NAME AND ADDRESS</b>	SPK Steel Fabrication 340 Broad St. PO Box 149 Fitchburg MA 01420	Kistner Concrete 8713 Read Road E. Pembroke NY 14056	Ferguson Waterworks 6040 Drott Drive E Syracuse NY 13057	Blair Supply Corp 785 Beahan Road Rochester NY 14624	Neenah Enterprises Inc. 2121 Brooks Ave Neenah WI 54956
			<b>CATCH BASIN AND MANHOLE MATERIALS</b>					
168	75	EA.	Catch Basins, per Exhibit D, 3' x 3' outer diameter	NO BID	<sup>1</sup> 650.78 Full load	NO BID	NO BID	NO BID
169	50	EA.	Manhole <b>Frames</b> per Exhibit D, 7" rise	NO BID	NO BID	NO BID	NO BID	<sup>7</sup> 183.00
170	50	EA.	Manhole <b>Covers</b> per Exhibit D, 7" rise	NO BID	NO BID	NO BID	NO BID	<sup>7</sup> 158.00
171	175	EA.	Catch Basin <b>Frames</b> per Exhibit D, 6" rise	NO BID	NO BID	NO BID	NO BID	<sup>7</sup> 205.00
172	175	EA.	Catch Basin <b>Grates</b> per Exhibit D, 6" rise	NO BID	NO BID	NO BID	NO BID	<sup>7</sup> 203.00
173	25	EA.	Catch Basin <b>Frames</b> per Exhibit D, 3" rise	NO BID	NO BID	NO BID	NO BID	<sup>7</sup> 158.00
174	25	EA.	Catch Basin <b>Grates</b> per Exhibit D, 3" rise	NO BID	NO BID	NO BID	NO BID	<sup>7</sup> 157.00
175	200	EA.	Catch Basin <b>Traps</b> per Exhibit D, 8" diameter	NO BID	NO BID	NO BID	NO BID	NO BID
			<b>SOLID MANHOLE RISER RINGS</b> (per the specifications and drawing in Appendix D, Page 55, or City approved equal)					<sup>7</sup> 90 Days Lead Time
176	110	EA.	24" x 1" by 1"	110.00	NO BID	NO BID	NO BID	<sup>7</sup> 165.00
177	110	EA.	24" x 1" by 1.5"	110.00	NO BID	NO BID	NO BID	<sup>7</sup> 172.00
178	110	EA.	24" x 1" by 2"	130.00	NO BID	NO BID	NO BID	<sup>7</sup> 180.00

**OFFICIAL TALLY SHEET**

**NIAGARA FALLS WATER BOARD BID #W2023-01 WATER AND SEWER CONSTRUCTION AND REPAIR MATERIALS SET 1 OF 2**

**OPENING DATE: WEDNESDAY, JULY 12, 2023 AT 10:00 AM**

Page 17 of 20

ITEM #	EST. QTY	UNIT	DESCRIPTION	UNIT PRICE	UNIT PRICE	UNIT PRICE	UNIT PRICE	UNIT PRICE
			<b>VENDOR NAME AND ADDRESS</b>	SPK Steel Fabrication 340 Broad St. PO Box 149 Fitchburg MA 01420	Kistner Concrete 8713 Read Road E. Pembroke NY 14056	Ferguson Waterworks 6040 Drott Drive E Syracuse NY 13057	Blair Supply Corp 785 Beahan Road Rochester NY 14624	Neenah Enterprises Inc. 2121 Brooks Ave Neenah WI 54956
			<b>FERNCO COUPLINGS/ADAPTERS</b>					
177C	10	EA.	36" Clay to Plastic	NO BID	NO BID	1155.00	1075.00	NO BID
178C	10	EA.	36" Plastic to Plastic	NO BID	NO BID	860.00	790.00	NO BID
179	10	EA.	24" Clay to Plastic	NO BID	NO BID	148.00	134.00	NO BID
180	10	EA.	24" Plastic to Plastic	NO BID	NO BID	148.00	134.00	NO BID
181	10	EA.	20" Clay to Plastic	NO BID	NO BID	NO BID	NO BID	NO BID
182	10	EA.	20" Plastic to Plastic	NO BID	NO BID	118.00	113.00	NO BID
183	10	EA.	18" Clay to Plastic	NO BID	NO BID	110.00	101.00	NO BID
184	10	EA.	18" Plastic to Plastic	NO BID	NO BID	110.00	101.00	NO BID
185	6	EA.	15" Clay to Plastic	NO BID	NO BID	49.50	45.00	NO BID
186	6	EA.	15" Plastic to Plastic	NO BID	NO BID	49.50	45.00	NO BID
187	10	EA.	12" Clay to Plastic	NO BID	NO BID	31.00	29.00	NO BID
188	10	EA.	12" Plastic to Plastic	NO BID	NO BID	31.00	29.00	NO BID
189	20	EA.	10" Clay to Plastic	NO BID	NO BID	27.00	26.00	NO BID

**OFFICIAL TALLY SHEET**

**NIAGARA FALLS WATER BOARD BID #W2023-01 WATER AND SEWER CONSTRUCTION AND REPAIR MATERIALS SET 1 OF 2**

**OPENING DATE: WEDNESDAY, JULY 12, 2023 AT 10:00 AM**

Page 18 of 20

			VENDOR NAME AND ADDRESS					
ITEM #	EST. QTY	UNIT	DESCRIPTION	UNIT PRICE	UNIT PRICE	UNIT PRICE	UNIT PRICE	UNIT PRICE
			<b>FERNCO COUPLINGS/ADAPTERS</b>					
190	20	EA.	10" Plastic to Plastic	NO BID	NO BID	27.00	26.00	NO BID
191	50	EA.	8" Clay to Plastic	NO BID	NO BID	18.00	17.00	NO BID
192	50	EA.	8" Plastic to Plastic	NO BID	NO BID	18.00	17.00	NO BID
193	30	EA.	6" Clay to Plastic	NO BID	NO BID	11.50	12.00	NO BID
194	30	EA.	6" Plastic to Plastic	NO BID	NO BID	11.50	12.00	NO BID
195	10	EA.	4" Clay to Plastic	NO BID	NO BID	5.50	6.00	NO BID
196	10	EA.	4" Plastic to Plastic	NO BID	NO BID	5.50	6.00	NO BID
			<b>SEWER PIPE SDR 35 (PVC), PER FOOT OF LENGTH</b>					
197		FT.	36" Diameter	NO BID	NO BID	NO BID	NO BID	NO BID
198		FT.	30" Diameter	NO BID	NO BID	NO BID	NO BID	NO BID
199		FT.	24" Diameter	NO BID	NO BID	NO BID	NO BID	NO BID
200		FT.	20" Diameter	NO BID	NO BID	NO BID	NO BID	NO BID
201		FT.	18" Diameter	NO BID	NO BID	NO BID	NO BID	NO BID
202		FT.	15" Diameter	NO BID	NO BID	NO BID	NO BID	NO BID
203		FT.	12" Diameter	NO BID	NO BID	NO BID	NO BID	NO BID
204		FT.	10" Diameter	NO BID	NO BID	NO BID	NO BID	NO BID



**OFFICIAL TALLY SHEET**

**NIAGARA FALLS WATER BOARD BID #W2023-01 WATER AND SEWER CONSTRUCTION AND REPAIR MATERIALS SET 1 OF 2**

**OPENING DATE: WEDNESDAY, JULY 12, 2023 AT 10:00 AM**

Page 19 of 20

ITEM #	EST. QTY	UNIT	DESCRIPTION	UNIT PRICE	UNIT PRICE	UNIT PRICE	UNIT PRICE	UNIT PRICE	
			<b>VENDOR NAME AND ADDRESS</b>						
				SPK Steel Fabrication 340 Broad St. PO Box 149 Fitchburg MA 01420	Kistner Concrete 8713 Read Road E. Pembroke NY 14056	Ferguson Waterworks 6040 Drott Drive E Syracuse NY 13057	Blair Supply Corp 785 Beahan Road Rochester NY 14624	Neenah Enterprises Inc. 2121 Brooks Ave Neenah WI 54956	
			<b>SEWER PIPE SDR 35 (PVC), PER FOOT OF LENGTH</b>						
205		FT.	8" Diameter	NO BID	NO BID	NO BID	NO BID	NO BID	
206		FT.	6" Diameter	NO BID	NO BID	NO BID	NO BID	NO BID	
207		FT.	4" Diameter	NO BID	NO BID	NO BID	NO BID	NO BID	
			<b>DUCTILE IRON PIPE, PER FOOT OF LENGTH</b>						
208			18" Diameter	NO BID	NO BID	NO BID	NO BID	NO BID	
209			15" Diameter	NO BID	NO BID	NO BID	NO BID	NO BID	
210			12" Diameter	NO BID	NO BID	NO BID	NO BID	NO BID	
211			10" Diameter	NO BID	NO BID	NO BID	NO BID	NO BID	
212			8" Diameter	NO BID	NO BID	NO BID	NO BID	NO BID	
213			6" Diameter	NO BID	NO BID	NO BID	NO BID	NO BID	
214			4" Diameter	NO BID	NO BID	NO BID	NO BID	NO BID	
215			4" Diameter	NO BID	NO BID	NO BID	NO BID	NO BID	

See Page 20 for Notes Section

OFFICIAL TALLY SHEET

NIAGARA FALLS WATER BOARD BID #W2023-01 WATER AND SEWER CONSTRUCTION AND REPAIR MATERIALS SET 1 OF 2

OPENING DATE: WEDNESDAY, JULY 12, 2023 AT 10:00 AM

Page 20 of 20

**NOTES:**

Kistner Concrete: Item #168: <sup>1</sup> Price is for full loads only.

Ferguson Waterworks: <sup>2</sup>Quoting Bingham & Taylor for all Valve Box and Curb box items

<sup>3</sup>Quoting Hi-Max --- Item #39 -44

<sup>4</sup>Quoting Smith -Blair Model 261 & 264 --- Item # 54-70

<sup>5</sup>Quoting Stargrips --- Item # 85-94

<sup>6</sup>Quoting Blue Bolt & Gasket Packs --- Item # 156-158

Neenah Enterprises <sup>7</sup>90-Day lead time --- Item # 169-178

No bids received for Item # 53, 102, 140, 175, and 200.

**OFFICIAL TALLY SHEET**

**NIAGARA FALLS WATER BOARD BID #W2023-01 WATER AND SEWER CONSTRUCTION AND REPAIR MATERIALS SET 2 OF 2**

**OPENING DATE: WEDNESDAY, JULY 12, 2023 AT 10:00 AM**

Page 1 of 20

VENDOR NAME AND ADDRESS								
				Core & Main 650 West Ave Lockport NY 14094	EJP 200 Lake Ave Blasdell NY 14219	K & S Contractors Supply 1971 Gunnville Rd Lancaster NY 14086	Ti Sales 36 Hudson Road Sudbury MA 01776	XXX
ITEM	EST.	UNIT	DESCRIPTION	UNIT PRICE	UNIT PRICE	UNIT PRICE	UNIT PRICE	UNIT PRICE
<b>STANDARD BURY FIRE HYDRANTS (MUELLER CENTURION KENNEDY GUARDIAN)</b>								
1	5	EA.	4 FT. Bury	3415.00	NO BID	3338.06	NO BID	
2	15	EA.	5 FT. Bury	3574.00	NO BID	3493.14	NO BID	
3	5	EA.	6 FT. Bury	3733.00	NO BID	3648.22	NO BID	
<b>BREAKAWAY KITS</b>								
4	15	EA.	Breakaway Kits for Kennedy Guardian	329.00	NO BID	281.53	NO BID	
5	15	EA.	Breakaway Kits for Mueller Centurion	329.00	NO BID	NO BID	NO BID	
<b>CAST IRON CURB &amp; VALVE BOX PARTS, ALL SCREW TYPE VALVES AND CURB BOXES SHALL BE AS MANUFACTURED BY BIBBY-ST. CROIX FOUNDRIES INC. OR EQUIVALENT COVERS SHALL BE CAST WITH "WATER" LABEL ON TOP VALVE ROAD BOXES</b>								
6	20	EA.	Bases 14 3/8" base, 8 1/4" top, 12 3/8" high	100.00	NO BID	64.93	NO BID	
7	20	EA.	Top Sections 26"	119.00	NO BID	66.90	NO BID	
8	20	EA.	Top Sections 17"	77.00	NO BID	42.53	NO BID	

**OFFICIAL TALLY SHEET**

**NIAGARA FALLS WATER BOARD BID #W2023-01 WATER AND SEWER CONSTRUCTION AND REPAIR MATERIALS SET 2 OF 2**

**OPENING DATE: WEDNESDAY, JULY 12, 2023 AT 10:00 AM**

Page 2 of 20

			VENDOR NAME AND ADDRESS					
				Core & Main 650 West Ave Lockport NY 14094	EJP 200 Lake Ave Blasdell NY 14219	K & S Contractors Supply 1971 Gunville Rd Lancaster NY 14086	Ti Sales 36 Hudson Road Sudbury MA 01776	XXX
ITEM #	EST. QTY	UNIT	DESCRIPTION	UNIT PRICE	UNIT PRICE	UNIT PRICE	UNIT PRICE	UNIT PRICE
9	20	EA.	Bottom Sections 30"	112.00	NO BID	61.38	NO BID	
10	20	EA.	Bottom Sections 24"	83.00	NO BID	NO BID	NO BID	
11	20	EA.	Bottom Sections 16"	59.00	NO BID	NO BID	NO BID	
12	30	EA.	Shaft Extensions 26"	88.00	NO BID	NO BID	NO BID	
13	30	EA.	Shaft Extensions 16"	73.00	NO BID	NO BID	NO BID	
<b>VALVE BOX HEIGHT ADAPTERS (For Adjusting Boxes to Pavement Level)</b>								
14	50	EA.	Slide Type: Adjustment Range 2-1/2" to 8" 10-3/4" Height; 4-3/8" inner diameter	58.61	NO BID	NO BID	NO BID	
15	50	EA.	Screw-Type, Adjustment Range 2-1/2" to 8" 16-1/2" Height; 5-1/4" inner diameter	NO BID	NO BID	NO BID	NO BID	
16	50	EA.	Valve Box Riser V829 Fixed 5-1/4 x 1	25.00	NO BID	NO BID	NO BID	
17	50	EA.	Valve Box Riser V830 Fixed 5-1/4 x 1-1/2	30.00	NO BID	NO BID	NO BID	
18	50	EA.	Valve Box Riser V831 Fixed 5-1/4 x 2	35.00	NO BID	NO BID	NO BID	
<b>VALVE BOX REGULATOR COVERS 5-1/4"</b>								
19	40	EA.	(MARKED WATER)	25.00	NO BID	<sup>10</sup> 16.82	NO BID	

**OFFICIAL TALLY SHEET**

**NIAGARA FALLS WATER BOARD BID #W2023-01 WATER AND SEWER CONSTRUCTION AND REPAIR MATERIALS SET 2 OF 2**

**OPENING DATE: WEDNESDAY, JULY 12, 2023 AT 10:00 AM**

Page 3 of 20

			VENDOR NAME AND ADDRESS					
				Core & Main 650 West Ave Lockport NY 14094	EJP 200 Lake Ave Blasdell NY 14219	K & S Contractors Supply 1971 Gunnville Rd Lancaster NY 14086	Ti Sales 36 Hudson Road Sudbury MA 01776	XXX
ITEM #	EST. QTY	UNIT	DESCRIPTION	UNIT PRICE	UNIT PRICE	UNIT PRICE	UNIT PRICE	UNIT PRICE
<b>CURB BOXES</b>								
20	25	EA.	Bottom 33"	48.00	NO BID	NO BID	NO BID	
21	25	EA.	Bottom 24"	27.00	NO BID	NO BID	NO BID	
22	25	EA.	Top Section w/Cover 16"	NO BID	NO BID	NO BID	NO BID	
23	25	EA.	Top Section w/Cover 24"	93.00	NO BID	NO BID	NO BID	
24	25	EA.	Extension 9"	22.00	NO BID	NO BID	NO BID	
25	25	EA.	Extension 16"	31.00	NO BID	NO BID	NO BID	
26	50	EA.	Old Style Repair Lid (Outside Lip)	20.00	NO BID	NO BID	NO BID	
27	50	EA.	New Style Repair Lid (Inside Up)	20.00	NO BID	NO BID	NO BID	
<b>CAST IRON VALVE ROAD BOX RISERS</b>								
28	30	EA.	1"	22.66	NO BID	19.25	NO BID	
29	15	EA.	2"	31.14	NO BID	25.11	NO BID	
30	10	EA.	4"	55.42	NO BID	36.83	NO BID	
31	10	EA.	6"	151.00	NO BID	50.22	NO BID	

**OFFICIAL TALLY SHEET**

**NIAGARA FALLS WATER BOARD BID #W2023-01 WATER AND SEWER CONSTRUCTION AND REPAIR MATERIALS SET 2 OF 2**

**OPENING DATE: WEDNESDAY, JULY 12, 2023 AT 10:00 AM**

Page 4 of 20

ITEM #	EST. QTY	UNIT	VENDOR NAME AND ADDRESS	UNIT PRICE	UNIT PRICE	UNIT PRICE	UNIT PRICE	UNIT PRICE
			Core & Main 650 West Ave Lockport NY 14094					
			EJP 200 Lake Ave Blasdell NY 14219					
			K & S Contractors Supply 1971 Gunnville Rd Lancaster NY 14086					
			Ti Sales 36 Hudson Road Sudbury MA 01776					XXX
			DESCRIPTION	UNIT PRICE	UNIT PRICE	UNIT PRICE	UNIT PRICE	UNIT PRICE
			<b>DUCTILE IRON PIPE – ANSI/AWWA C151/A21.51 CLASS 52 STANDARD 18’ – 20’ LENGTHS – PUSH-ON JOINT</b>					
32	95	FEET	4”	41.83	<sup>8</sup> 40.76	NO BID	NO BID	
33	190	FEET	6”	32.15	<sup>8</sup> 31.33	NO BID	NO BID	
34	95	FEET	8”	45.37	<sup>8</sup> 44.20	NO BID	NO BID	
35	95	FEET	10”	59.47	<sup>8</sup> 57.94	NO BID	NO BID	
36	120	FEET	12”	74.88	<sup>8</sup> 72.95	NO BID	NO BID	
37	40	FEET	16”	131.30	<sup>8</sup> 105.58	NO BID	NO BID	
38	120	FEET	20”	150.27	<sup>8</sup> 138.62	NO BID	NO BID	
			<b>TRANSITION COUPLINGS (DRESSER TYPE) – COMPRESSION TYPE WITH ALL ACCESSORIES TO ADAPT FROM CAST IRON TO DUCTILE IRON PIPE – CLASS 52 AWWA 151</b>					
39	26	EA.	4”	68.04	86.36	73.98	NO BID	
40	30	EA.	6”	87.27	111.36	102.08	NO BID	
41	14	EA.	8”	117.42	136.36	128.42	NO BID	
42	18	EA.	10”	153.41	179.55	145.71	NO BID	

**OFFICIAL TALLY SHEET**

**NIAGARA FALLS WATER BOARD BID #W2023-01 WATER AND SEWER CONSTRUCTION AND REPAIR MATERIALS SET 2 OF 2**

**OPENING DATE: WEDNESDAY, JULY 12, 2023 AT 10:00 AM**

Page 5 of 20

ITEM #	EST. QTY	UNIT	DESCRIPTION	UNIT PRICE	UNIT PRICE	UNIT PRICE	UNIT PRICE	UNIT PRICE
			<b>TRANSITION COUPLINGS (DRESSER TYPE) – COMPRESSION TYPE WITH ALL ACCESSORIES TO ADAPT FROM CAST IRON TO DUCTILE IRON PIPE – CLASS 52 AWWA 151 (CONTINUED)</b>					
			<b>VENDOR NAME AND ADDRESS</b>	Core & Main 650 West Ave Lockport NY 14094	EJP 200 Lake Ave Blasdell NY 14219	K & S Contractors Supply 1971 Gunville Rd Lancaster NY 14086	Ti Sales 36 Hudson Road Sudbury MA 01776	XXX
43	8	EA.	12"	197.60	212.50	237.11	NO BID	
44	10	EA.	20"	343.49	811.36	579.96	NO BID	
			<b>PVC WATERMAIN – AWWA C900 DR-18 – PER STICK</b>					
45	6	Stick	4" x 20' Length	163.40	123.00	NO BID	NO BID	
46	6	Stick	6" x 20' Length	333.20	251.20	NO BID	NO BID	
47	4	Stick	8" x 20' Length	571.60	430.60	NO BID	NO BID	
48	5	Stick	10" x 20' Length	857.40	646.00	NO BID	NO BID	
49	5	Stick	12" x 20' Length	1207.40	909.80	NO BID	NO BID	
50	5	Stick	16" x 20' Length	2030.00	1500.80	NO BID	NO BID	
51	5	Stick	20" x 20' Length	3016.00	2327.60	NO BID	NO BID	
52	5	Stick	24" x 20' Length	3800.00	3356.40	NO BID	NO BID	
53	5	Stick	36" x 20' Length	NO BID	NO BID	NO BID	NO BID	



**OFFICIAL TALLY SHEET**

**NIAGARA FALLS WATER BOARD BID #W2023-01 WATER AND SEWER CONSTRUCTION AND REPAIR MATERIALS SET 2 OF 2**

**OPENING DATE: WEDNESDAY, JULY 12, 2023 AT 10:00 AM**

Page 6 of 20

ITEM #	EST. QTY	UNIT	DESCRIPTION	UNIT PRICE	UNIT PRICE	UNIT PRICE	UNIT PRICE	UNIT PRICE
			<b>360 DEGREE STAINLESS STEEL REPAIR CLAMPS FORD FS SERIES OR EQUAL: 18-8 TYPE 304 SS 4" TO 10" IN ONE SECTION, 12" &amp; 16" IN TWO SECTIONS, OVER 16" IN THREE SECTIONS</b>					
			VENDOR NAME AND ADDRESS	Core & Main 650 West Ave Lockport NY 14094	EJP 200 Lake Ave Blasdell NY 14219	K & S Contractors Supply 1971 Gunnville Rd Lancaster NY 14086	Ti Sales 36 Hudson Road Sudbury MA 01776	XXX
54	10	EA.	4" x 12" 4.75 – 5.15	89.72	119.60	98.38	NO BID	
55	8	EA.	4" x 12" (w/tapped 1" cc outlet)	114.52	161.21	117.44	NO BID	
56	5	EA.	4" x 20" 4.75 – 5.15	150.40	211.20	183.65	NO BID	
57	20	EA.	6" x 12" 6.84 – 7.24	109.27	143.78	108.13	NO BID	
58	8	EA.	6" x 12" (w/tapped ¾" cc outlet)	134.07	185.37	130.69	NO BID	
59	4	EA.	6" x 12" (w/tapped 1" cc outlet)	134.07	185.37	130.69	NO BID	
60	6	EA.	6" x 20" 6.84 – 7.24	188.99	261.87	184.63	NO BID	
61	10	EA.	8" x 12" 9.05 – 9.30	127.33	169.07	119.20	NO BID	
62	6	EA.	8" x 12" (w/tapped ¾" cc outlet)	152.13	210.67	138.62	NO BID	
63	6	EA.	8" x 12" (w/tapped 1" cc outlet)	152.13	210.67	138.62	NO BID	
64	6	EA.	8" x 20" 9.05 – 9.30	212.38	282.93	206.13	NO BID	
65	6	EA.	10" x 12-1/2" 11.04 – 11.44	162.41	228.37	166.14	NO BID	
66	6	EA.	10" x 12-1/2" (w/tapped ¾" cc outlet)	187.22	269.65	183.77	NO BID	

**OFFICIAL TALLY SHEET**

**NIAGARA FALLS WATER BOARD BID #W2023-01 WATER AND SEWER CONSTRUCTION AND REPAIR MATERIALS SET 2 OF 2**

**OPENING DATE: WEDNESDAY, JULY 12, 2023 AT 10:00 AM**

Page 7 of 20

			VENDOR NAME AND ADDRESS					
				Core & Main 650 West Ave Lockport NY 14094	EJP 200 Lake Ave Blasdell NY 14219	K & S Contractors Supply 1971 Gunnville Rd Lancaster NY 14086	Ti Sales 36 Hudson Road Sudbury MA 01776	XXX
ITEM #	EST. QTY	UNIT	DESCRIPTION	UNIT PRICE	UNIT PRICE	UNIT PRICE	UNIT PRICE	UNIT PRICE
			<b>360 DEGREE STAINLESS STEEL REPAIR CLAMPS FORD FS SERIES OR EQUAL: 18-8 TYPE 304 SS 4" TO 10" IN ONE SECTION, 12" &amp; 16" IN TWO SECTIONS, OVER 16" IN THREE SECTIONS</b>					
67	6	EA.	10" x 12-1/2" (w/tapped 1" cc outlet)	187.22	269.65	183.17	NO BID	
68	6	EA.	10" x 12-1/2" oversized 11.37 – 11.75	162.81	NO BID	163.14	NO BID	
69	6	EA.	10" x 20" Full Circle	259.07	NO BID	247.05	NO BID	
70	6	EA.	12" x 15" 13.20 – 13.50	223.68	400.51	203.48	NO BID	
			<b>GATE VALVES – CUT – IN MJ X MJ TYPE RESILIENT SEAT (WITH ALL ACCESSORIES) BONNET STUFFING BOX AND RETAINING BOLTS, NUTS AND WASHERS TO BE STAINLESS STEEL; ALL CLOSE CLOCKWISE AWWA C509 MUELLER CO. OR EQUAL</b>					
71	6	EA.	4"	1446.00	868.24	1108.96	NO BID	
72	6	EA.	6"	1967.00	1110.79	1515.24	NO BID	
73	6	EA.	8"	3050.00	1709.76	2322.15	NO BID	
74	4	EA.	10"	NO BID	2748.04	3323.47	NO BID	

**OFFICIAL TALLY SHEET**

**NIAGARA FALLS WATER BOARD BID #W2023-01 WATER AND SEWER CONSTRUCTION AND REPAIR MATERIALS SET 2 OF 2**

**OPENING DATE: WEDNESDAY, JULY 12, 2023 AT 10:00 AM**

Page 8 of 20

			VENDOR NAME AND ADDRESS					
				Core & Main 650 West Ave Lockport NY 14094	EJP 200 Lake Ave Blasdell NY 14219	K & S Contractors Supply 1971 Gunnville Rd Lancaster NY 14086	Ti Sales 36 Hudson Road Sudbury MA 01776	XXX
ITEM #	EST. QTY	UNIT	DESCRIPTION	UNIT PRICE	UNIT PRICE	UNIT PRICE	UNIT PRICE	UNIT PRICE
			<b>BUTTERFLY VALVES – MJ X MJ (WITH ALL ACCESSORIES) ALL CLOSE CLOCKWISE – AWWA C504 – PRATT OR MUELLER</b>					
75	2	EA.	12"	1910.00	2255.37	1876.29	NO BID	
76	2	EA.	16"	3758.00	4399.01	3690.72	NO BID	
77	2	EA.	20"	5320.00	6325.84	5226.80	NO BID	
78	2	EA.	24"	7371.00	8699.11	7237.11	NO BID	
			<b>MECHANICAL JOINT ACCESSORIES PACKAGE TO INCLUDE: GLAND; RUBBER GASKET AND BOLT KITS MJ ENDS AND ACCESSORIES – ANSI/AWWA C111/21.11</b>					
79	12	EA.	4"	41.00	NO BID	24.87	NO BID	
80	12	EA.	6"	54.00	NO BID	34.43	NO BID	
81	12	EA.	8"	56.00	NO BID	34.43	NO BID	
82	12	EA.	10"	83.00	NO BID	45.43	NO BID	
83	12	EA.	12"	88.00	NO BID	48.30	NO BID	
84	12	EA.	16"	152.00	NO BID	85.61	NO BID	

**OFFICIAL TALLY SHEET**

**NIAGARA FALLS WATER BOARD BID #W2023-01 WATER AND SEWER CONSTRUCTION AND REPAIR MATERIALS SET 2 OF 2**

**OPENING DATE: WEDNESDAY, JULY 12, 2023 AT 10:00 AM**

Page 9 of 20

			VENDOR NAME AND ADDRESS					
				Core & Main 650 West Ave Lockport NY 14094	EJP 200 Lake Ave Blasdell NY 14219	K & S Contractors Supply 1971 Gunville Rd Lancaster NY 14086	Ti Sales 36 Hudson Road Sudbury MA 01776	XXX
ITEM #	EST. QTY	UNIT	DESCRIPTION	UNIT PRICE	UNIT PRICE	UNIT PRICE	UNIT PRICE	UNIT PRICE
			<b>MECHANICAL RESTRAINTS SERIES 1100 TO INCLUDE: GLAND; RUBBER GASKET AND BOLT KITS</b>					
85	10	EA.	4"	65.00	NO BID	46.53	NO BID	
86	10	EA.	6"	81.00	NO BID	63.45	NO BID	
87	10	EA.	6" Series 1100X Oversize	105.00	NO BID	65.76	NO BID	
88	6	EA.	8"	98.00	NO BID	74.78	NO BID	
89	6	EA.	10"	137.00	NO BID	107.82	NO BID	
90	6	EA.	12"	174.00	NO BID	NO BID	NO BID	
91	6	EA.	36"	1751.00	NO BID	NO BID	NO BID	
			<b>MEGALUG RESTRAINTS TO INCLUDE GLAND; RUBBER GASKET AND BOLT KITS</b>					
92	6	EA.	1116 Series, Ductile Iron, 16"	276.50	NO BID	NO BID	NO BID	
93	6	EA.	1120 Series, Ductile Iron, 20"	428.00	NO BID	NO BID	NO BID	
94	6	EA.	1124 Series, Ductile Iron, 24"	600.00	NO BID	NO BID	NO BID	

**OFFICIAL TALLY SHEET**

**NIAGARA FALLS WATER BOARD BID #W2023-01 WATER AND SEWER CONSTRUCTION AND REPAIR MATERIALS SET 2 OF 2**

**OPENING DATE: WEDNESDAY, JULY 12, 2023 AT 10:00 AM**

Page 10 of 20

VENDOR NAME AND ADDRESS								
				Core & Main 650 West Ave Lockport NY 14094	EJP 200 Lake Ave Blasdell NY 14219	K & S Contractors Supply 1971 Gunnville Rd Lancaster NY 14086	Ti Sales 36 Hudson Road Sudbury MA 01776	XXX
ITEM #	EST. QTY	UNIT	DESCRIPTION	UNIT PRICE	UNIT PRICE	UNIT PRICE	UNIT PRICE	UNIT PRICE
			<b>PLASTIC/BRASS/COPPER SERVICE LINE MATERIALS BUSHINGS; (MUELLER (CC) THREAD) MUELLER H-10036, FORD BBAA SERIES OR EQUAL</b>					
95	12	EA.	1" cc x 3/4" cc	66.00	18.00	14.93	<sup>11</sup> 16.88	
96	12	EA.	1-1/2" cc x 3/4" cc	NO BID	48.86	40.24	<sup>11</sup> 45.51	
97	12	EA.	1-1/2" cc x 1" cc	74.00	49.01	40.38	<sup>11</sup> 45.67	
98	6	EA.	2" cc x 3/4" cc	NO BID	78.22	64.43	<sup>11</sup> 77.52	
99	6	EA.	2" cc x 1" cc	104.50	79.99	65.89	<sup>11</sup> 79.29	
100	6	EA.	2" cc x 1-1/2" cc	110.00	59.65	49.15	<sup>11</sup> 89.14	
			<b>PLUGS: THREAD AS INDICATED MUELLER H-1003X SERIES, FORD CSP SERIES OR EQUAL</b>					
101	10	EA.	1/2" IPT	3.45	10.32	NO BID	NO BID	
102	10	EA.	5/8" IPT	NO BID	NO BID	NO BID	NO BID	
103	8	EA.	3/4" cc	23.50	11.05	9.09	NO BID	
104	4	EA.	3/4" IPT	4.50	10.37	8.55	NO BID	
105	4	EA.	1" cc	24.85	16.08	13.25	NO BID	
106	4	EA.	1" IPT	7.60	16.56	13.63	NO BID	

**OFFICIAL TALLY SHEET**

**NIAGARA FALLS WATER BOARD BID #W2023-01 WATER AND SEWER CONSTRUCTION AND REPAIR MATERIALS SET 2 OF 2**

**OPENING DATE: WEDNESDAY, JULY 12, 2023 AT 10:00 AM**

Page 11 of 20

			VENDOR NAME AND ADDRESS					
				Core & Main 650 West Ave Lockport NY 14094	EJP 200 Lake Ave Blasdell NY 14219	K & S Contractors Supply 1971 Gunnville Rd Lancaster NY 14086	Ti Sales 36 Hudson Road Sudbury MA 01776	XXX
ITEM #	EST. QTY	UNIT	DESCRIPTION	UNIT PRICE	UNIT PRICE	UNIT PRICE	UNIT PRICE	UNIT PRICE
			<b>PLUGS: THREAD AS INDICATED MUELLER H-1003X SERIES, FORD CSP SERIES OR EQUAL (CONTINUED)</b>					
107	4	EA.	1-1/2" cc	44.20	36.04	35.87	NO BID	
108	4	EA.	1-1/2" IPT	7.90	38.18	31.46	NO BID	
109	4	EA.	2" cc	58.00	46.74	61.45	NO BID	
110	4	EA.	2" IPT	12.45	46.74	56.02	NO BID	
			<b>LEAD PACK COMPRESSION COUPLINGS: LEAD ONE END/COPPER OTHER END – FORD NOS. &amp; SIZE (ALL ITEMS COMPLY WITH AWWA C-800-84)</b>					
111	35	EA.	Q28-33 3/4" strong to 3/4" IPT	NO BID	34.68	32.74	<sup>12</sup> 34.18	
112	35	EA.	Q38-33 3/4" XXS to 3/4" IPT	NO BID	40.40	38.26	<sup>12</sup> 39.95	
113	30	EA.	Q-14-33 3/4" strong to 3/4" copper comp.	NO BID	42.03	39.86	<sup>12</sup> 41.62	
114	35	EA.	Q24-33 3/4" XS to 3/4" copper comp.	NO BID	47.71	45.22	<sup>12</sup> 47.21	
115	35	EA.	Q34-43 3/4" XXS to 3/4" copper	NO BID	43.03	68.18	<sup>12</sup> 71.18	
116	20	EA.	Q24-43 1" XS TO 3/4" copper	NO BID	73.96	70.11	<sup>12</sup> 72.39	
117	20	EA.	Q34-43 1" XXS to 3/4" copper	NO BID	71.92	68.18	<sup>12</sup> 70.40	
118	14	EA.	Q14-44 1" strong to 1" copper	NO BID	77.86	73.81	<sup>12</sup> 76.22	

**OFFICIAL TALLY SHEET**

**NIAGARA FALLS WATER BOARD BID #W2023-01 WATER AND SEWER CONSTRUCTION AND REPAIR MATERIALS SET 2 OF 2**

**OPENING DATE: WEDNESDAY, JULY 12, 2023 AT 10:00 AM**

Page 12 of 20

ITEM #	EST. QTY	UNIT	DESCRIPTION	UNIT PRICE	UNIT PRICE	UNIT PRICE	UNIT PRICE	UNIT PRICE
			<b>VENDOR NAME AND ADDRESS</b>	Core & Main 650 West Ave Lockport NY 14094	EJP 200 Lake Ave Blasdell NY 14219	K & S Contractors Supply 1971 Gunnville Rd Lancaster NY 14086	Ti Sales 36 Hudson Road Sudbury MA 01776	XXX
			<b>LEAD PACK COMPRESSION COUPLINGS: LEAD ONE END/COPPER OTHER END – FORD NOS. &amp; SIZE (ALL ITEMS COMPLY WITH AWWA C-800-84) (CONTINUED)</b>					
119	6	EA.	Q24-44 1" XS to 1" copper	NO BID	76.14	72.18	<sup>12</sup> 74.53	
120	12	EA.	Q34-44 1" XXS to 1" copper	NO BID	69.82	66.20	<sup>12</sup> 68.36	
121	10	EA.	Q24-66 1-1/2" XS to 1-1/2" copper	NO BID	122.16	116.45	<sup>12</sup> 120.25	
122	10	EA.	Q24-77 2 XS to 2" copper	NO BID	198.41	188.11	<sup>12</sup> 194.24	
			<b>ADAPTERS – ALL COMPRESSION:</b>					
123	50	EA.	¾" Male H-15-428	27.70	18.73	17.75	NO BID	
124	50	EA.	¾" Female H-15-451	29.70	19.69	18.67	NO BID	
125	30	EA.	1" Male IPT to 1" Copper Compression	32.70	22.19	21.02	NO BID	
126	30	EA.	1" Female IPT to 1" Copper Compression	42.45	26.71	25.33	NO BID	
127	8	EA.	1-1/2" Male IPT to 1-1/2" Copper Compression	90.50	60.74	57.58	NO BID	
128	8	EA.	1-1/2" Female IPT to 1-1/2" Copper Compression	115.70	77.70	73.64	NO BID	
129	8	EA.	2" Female IPT H-15-451 to 2" Copper	137.90	92.49	87.69	NO BID	
130	8	EA.	2" Male IPT H-15-428	131.80	88.49	83.89	NO BID	



**OFFICIAL TALLY SHEET**

**NIAGARA FALLS WATER BOARD BID #W2023-01 WATER AND SEWER CONSTRUCTION AND REPAIR MATERIALS SET 2 OF 2**

**OPENING DATE: WEDNESDAY, JULY 12, 2023 AT 10:00 AM**

Page 13 of 20

			VENDOR NAME AND ADDRESS					
				Core & Main 650 West Ave Lockport NY 14094	EJP 200 Lake Ave Blasdell NY 14219	K & S Contractors Supply 1971 Gunnville Rd Lancaster NY 14086	Ti Sales 36 Hudson Road Sudbury MA 01776	XXX
ITEM #	EST. QTY	UNIT	DESCRIPTION	UNIT PRICE	UNIT PRICE	UNIT PRICE	UNIT PRICE	UNIT PRICE
			<b>CORPORATION STOPS (Ford or Mueller Equivalent) FORD NOS. &amp; SIZE</b>					
131	12	EA.	F600-L04-33S ¾" Copper Corp. w/swivel – 90 degree compression	144.00	92.02	68.52	NO BID	
132	50	EA.	F600-L04-44S 1" Copper Corp. w/swivel – 90 degree compression	194.00	119.56	98.49	NO BID	
133	12	EA.	F700-L0445 1" Iron pip w/swivel – 90 degree compression	194.00	126.41	98.49	NO BID	
134	4	EA.	H-15-071-L04-66 1-1/2" Copper Corp. w/swivel 90 degree compression	286.00	290.19	280.66	NO BID	
135	4	EA.	H-15-071-L04-77 2" Copper Corp. w/swivel – 90 degree compression	448.00	496.58	481.23	NO BID	
136	5	EA.	2" FB 800 AWWA Thread	NO BID	278.64	264.17	NO BID	
137	12	EA.	¾" 90 Degree Angle Meter Coupling L-38-23	NO BID	17.89	16.95	NO BID	
138	10	EA.	1" 90 Degree Angle Meter Coupling L-38-44	NO BID	25.53	24.17	NO BID	
139	6	EA.	1" IPT Female Cap	6.00	6.84	NO BID	NO BID	
140	6	EA.	¾" IPT Inlet w/1" Male IPT Outlet	NO BID	NO BID	NO BID	NO BID	
			<b>COPPER TUBING – TYPE K</b>					
141	10	EA.	60 Foot Rolls – ¾"	450.00	405.00	NO BID	NO BID	
142	5	EA.	60 Foot Rolls – 1"	540.00	540.00	NO BID	NO BID	
143	4	EA.	60 Foot Rolls – 1-1/2"	900.00	870.00	NO BID	NO BID	
144	4	EA.	60 Foot Rolls – 2"	1080.00	1350.00	NO BID	NO BID	

**OFFICIAL TALLY SHEET**

**NIAGARA FALLS WATER BOARD BID #W2023-01 WATER AND SEWER CONSTRUCTION AND REPAIR MATERIALS SET 2 OF 2**

**OPENING DATE: WEDNESDAY, JULY 12, 2023 AT 10:00 AM**

Page 14 of 20

			VENDOR NAME AND ADDRESS					
				Core & Main 650 West Ave Lockport NY 14094	EJP 200 Lake Ave Blasdell NY 14219	K & S Contractors Supply 1971 Gunnville Rd Lancaster NY 14086	Ti Sales 36 Hudson Road Sudbury MA 01776	XXX
ITEM #	EST. QTY	UNIT	DESCRIPTION	UNIT PRICE	UNIT PRICE	UNIT PRICE	UNIT PRICE	UNIT PRICE
			<b>CURB STOPS (Ford or Mueller Equivalent) FORD NOS. &amp; SIZE</b>					
145	16	EA.	B44-333 ¾" Copper	125.00	82.70	78.41	<sup>13</sup> 80.96	
146	25	EA.	B11-333 ¾" Reg. IPTHD	101.00	64.26	60.92	<sup>13</sup> 62.90	
147	8	EA.	B44-444 1" Copper	185.00	124.32	117.87	<sup>13</sup> 121.72	
148	8	EA.	B11-444 1" Reg IPTHD	150.00	99.86	94.69	<sup>13</sup> 97.78	
149	6	EA.	B44-666 1-1/2" Copper	450.00	297.49	282.03	<sup>13</sup> 291.23	
150	44	EA.	B44-777 2" Copper	625.00	418.21	396.49	<sup>13</sup> 409.42	
151	5	EA.	B11-777 2" Reg IPTHD	475.00	299.09	283.57	<sup>13</sup> 292.82	
152	20	EA.	Compression Coupling for ¾" Copper to ¾" Copper	36.00	22.79	21.61	<sup>14</sup> 22.32	
153	10	EA.	Compression Coupling 1" Copper to 1" Copper	39.00	26.08	24.73	<sup>14</sup> 25.53	
154	6	EA.	Compression Coupling 1-1/2" Copper to 1-1/2" Copper	130.00	87.25	82.74	<sup>14</sup> 85.43	
155	4	EA.	Compression Coupling 2" Copper to 2" Copper	165.00	117.82	111.68	<sup>14</sup> 115.33	

**OFFICIAL TALLY SHEET**

**NIAGARA FALLS WATER BOARD BID #W2023-01 WATER AND SEWER CONSTRUCTION AND REPAIR MATERIALS SET 2 OF 2**

**OPENING DATE: WEDNESDAY, JULY 12, 2023 AT 10:00 AM**

Page 15 of 20

ITEM #	EST. QTY	UNIT	DESCRIPTION	UNIT PRICE	UNIT PRICE	UNIT PRICE	UNIT PRICE	UNIT PRICE
			<b>VENDOR NAME AND ADDRESS</b>	Core & Main 650 West Ave Lockport NY 14094	EJP 200 Lake Ave Blasdell NY 14219	K & S Contractors Supply 1971 Gunnville Rd Lancaster NY 14086	Ti Sales 36 Hudson Road Sudbury MA 01776	XXX
			<b>MECHANICAL JOINTS, SHORT BODY (COMPACT) WITH FLUOROCARBON COATING</b>					
156	10	EA.	16"	NO BID	NO BID	NO BID	NO BID	
157	10	EA.	20"	NO BID	NO BID	NO BID	NO BID	
158	10	EA.	24"	NO BID	NO BID	NO BID	NO BID	
			<b>HYMAX COUPLINGS</b>					
159	20	EA.	4"	225.00	229.71	NO BID	<sup>15</sup> 247.49	
160	50	EA.	6"	299.00	304.22	NO BID	<sup>15</sup> 326.77	
161	20	EA.	8"	338.00	343.47	NO BID	<sup>15</sup> 370.06	
162	10	EA.	10"	435.00	441.86	NO BID	<sup>15</sup> 512.40	
163	6	EA.	12"	513.00	521.53	NO BID	<sup>15</sup> 684.77	
164	8	EA.	16" (860-56-0434-16P)	1404.00	1428.45	NO BID	NO BID	
165	6	EA.	20" (860-56-0540-16P)	1786.00	1814.87	NO BID	NO BID	
166	6	EA.	24" (860-56-0624-16P)	1900.00	1932.51	NO BID	NO BID	
167	2	EA.	36"	3793.00	3818.09	NO BID	NO BID	

**OFFICIAL TALLY SHEET**

**NIAGARA FALLS WATER BOARD BID #W2023-01 WATER AND SEWER CONSTRUCTION AND REPAIR MATERIALS SET 2 OF 2**

**OPENING DATE: WEDNESDAY, JULY 12, 2023 AT 10:00 AM**

Page 16 of 20

VENDOR NAME AND ADDRESS								
				Core & Main 650 West Ave Lockport NY 14094	EJP 200 Lake Ave Blasdell NY 14219	K & S Contractors Supply 1971 Gunnville Rd Lancaster NY 14086	Ti Sales 36 Hudson Road Sudbury MA 01776	XXX
ITEM #	EST. QTY	UNIT	DESCRIPTION	UNIT PRICE	UNIT PRICE	UNIT PRICE	UNIT PRICE	UNIT PRICE
<b>CATCH BASIN AND MANHOLE MATERIALS</b>								
168	75	EA.	Catch Basins, per Exhibit D, 3' x 3' outer diameter	NO BID	NO BID	NO BID	NO BID	
169	50	EA.	Manhole <b>Frames</b> per Exhibit D, 7" rise	NO BID	NO BID	NO BID	NO BID	
170	50	EA.	Manhole <b>Covers</b> per Exhibit D, 7" rise	NO BID	NO BID	NO BID	NO BID	
171	175	EA.	Catch Basin <b>Frames</b> per Exhibit D, 6" rise	NO BID	NO BID	NO BID	NO BID	
172	175	EA.	Catch Basin <b>Grates</b> per Exhibit D, 6" rise	NO BID	NO BID	NO BID	NO BID	
173	25	EA.	Catch Basin <b>Frames</b> per Exhibit D, 3" rise	NO BID	NO BID	NO BID	NO BID	
174	25	EA.	Catch Basin <b>Grates</b> per Exhibit D, 3" rise	NO BID	NO BID	NO BID	NO BID	
175	200	EA.	Catch Basin <b>Traps</b> per Exhibit D, 8" diameter	NO BID	NO BID	NO BID	NO BID	
<b>SOLID MANHOLE RISER RINGS</b> (per the specifications and drawing in Appendix D, Page 55, or City approved equal)								
176	110	EA.	24" x 1" by 1"	NO BID	NO BID	NO BID	NO BID	
177	110	EA.	24" x 1" by 1.5"	NO BID	NO BID	NO BID	NO BID	
178	110	EA.	24" x 1" by 2"	NO BID	NO BID	NO BID	NO BID	

**OFFICIAL TALLY SHEET**

**NIAGARA FALLS WATER BOARD BID #W2023-01 WATER AND SEWER CONSTRUCTION AND REPAIR MATERIALS SET 2 OF 2**

**OPENING DATE: WEDNESDAY, JULY 12, 2023 AT 10:00 AM**

Page 17 of 20

			VENDOR NAME AND ADDRESS					
				Core & Main 650 West Ave Lockport NY 14094	EJP 200 Lake Ave Blasdell NY 14219	K & S Contractors Supply 1971 Gunville Rd Lancaster NY 14086	Ti Sales 36 Hudson Road Sudbury MA 01776	XXX
ITEM #	EST. QTY	UNIT	DESCRIPTION	UNIT PRICE	UNIT PRICE	UNIT PRICE	UNIT PRICE	UNIT PRICE
<b>FERNCO COUPLINGS/ADAPTERS</b>								
177C	10	EA.	36" Clay to Plastic	1204.58	1018.24	NO BID	NO BID	
178C	10	EA.	36" Plastic to Plastic	900.06	760.82	NO BID	NO BID	
179	10	EA.	24" Clay to Plastic	154.31	130.44	NO BID	NO BID	
180	10	EA.	24" Plastic to Plastic	154.31	132.00	NO BID	NO BID	
181	10	EA.	20" Clay to Plastic	124.84	106.00	NO BID	NO BID	
182	10	EA.	20" Plastic to Plastic	124.84	106.00	NO BID	NO BID	
183	10	EA.	18" Clay to Plastic	115.00	98.00	NO BID	NO BID	
184	10	EA.	18" Plastic to Plastic	115.00	98.00	NO BID	NO BID	
185	6	EA.	15" Clay to Plastic	51.95	43.50	NO BID	NO BID	
186	6	EA.	15" Plastic to Plastic	51.95	43.50	NO BID	NO BID	
187	10	EA.	12" Clay to Plastic	33.03	27.92	NO BID	NO BID	
188	10	EA.	12" Plastic to Plastic	33.03	27.92	NO BID	NO BID	
189	20	EA.	10" Clay to Plastic	28.31	23.93	NO BID	NO BID	

**OFFICIAL TALLY SHEET**

**NIAGARA FALLS WATER BOARD BID #W2023-01 WATER AND SEWER CONSTRUCTION AND REPAIR MATERIALS SET 2 OF 2**

**OPENING DATE: WEDNESDAY, JULY 12, 2023 AT 10:00 AM**

Page 18 of 20

			VENDOR NAME AND ADDRESS					
				Core & Main 650 West Ave Lockport NY 14094	EJP 200 Lake Ave Blasdell NY 14219	K & S Contractors Supply 1971 Gunnville Rd Lancaster NY 14086	Ti Sales 36 Hudson Road Sudbury MA 01776	XXX
ITEM #	EST. QTY	UNIT	DESCRIPTION	UNIT PRICE	UNIT PRICE	UNIT PRICE	UNIT PRICE	UNIT PRICE
<b>FERNCO COUPLINGS/ADAPTERS</b>								
190	20	EA.	10" Plastic to Plastic	28.31	23.93	NO BID	NO BID	
191	50	EA.	8" Clay to Plastic	18.86	15.95	NO BID	NO BID	
192	50	EA.	8" Plastic to Plastic	18.86	15.95	NO BID	NO BID	
193	30	EA.	6" Clay to Plastic	12.26	10.36	NO BID	NO BID	
194	30	EA.	6" Plastic to Plastic	3.39	10.36	NO BID	NO BID	
195	10	EA.	4" Clay to Plastic	5.73	4.85	NO BID	NO BID	
196	10	EA.	4" Plastic to Plastic	5.73	4.85	NO BID	NO BID	
<b>SEWER PIPE SDR 35 (PVC), PER FOOT OF LENGTH</b>								
197		FT.	36" Diameter	NO BID	248.00	NO BID	NO BID	
198		FT.	30" Diameter	NO BID	162.50	NO BID	NO BID	
199		FT.	24" Diameter	NO BID	97.90	NO BID	NO BID	
200		FT.	20" Diameter	NO BID	<sup>9</sup> 76.75	NO BID	NO BID	
201		FT.	18" Diameter	60.00	54.60	NO BID	NO BID	
202		FT.	15" Diameter	40.00	38.50	NO BID	NO BID	
203		FT.	12" Diameter	28.00	24.49	NO BID	NO BID	
204		FT.	10" Diameter	19.00	17.02	NO BID	NO BID	

**OFFICIAL TALLY SHEET**

**NIAGARA FALLS WATER BOARD BID #W2023-01 WATER AND SEWER CONSTRUCTION AND REPAIR MATERIALS SET 2 OF 2**

**OPENING DATE: WEDNESDAY, JULY 12, 2023 AT 10:00 AM**

Page 19 of 20

			VENDOR NAME AND ADDRESS					
				Core & Main 650 West Ave Lockport NY 14094	EJP 200 Lake Ave Blasdell NY 14219	K & S Contractors Supply 1971 Gunnville Rd Lancaster NY 14086	Ti Sales 36 Hudson Road Sudbury MA 01776	XXX
ITEM #	EST. QTY	UNIT	DESCRIPTION	UNIT PRICE	UNIT PRICE	UNIT PRICE	UNIT PRICE	UNIT PRICE
			<b>SEWER PIPE SDR 35 (PVC), PER FOOT OF LENGTH</b>					
205		FT.	8" Diameter	12.50	10.95	NO BID	NO BID	
206		FT.	6" Diameter	7.00	6.02	NO BID	NO BID	
207		FT.	4" Diameter	3.30	2.61	NO BID	NO BID	
			<b>DUCTILE IRON PIPE, PER FOOT OF LENGTH</b>					
208			18" Diameter	NO BID	129.53	NO BID	NO BID	
209			15" Diameter	NO BID	105.58	NO BID	NO BID	
210			12" Diameter	NO BID	72.95	NO BID	NO BID	
211			10" Diameter	NO BID	57.94	NO BID	NO BID	
212			8" Diameter	NO BID	44.20	NO BID	NO BID	
213			6" Diameter	NO BID	31.33	NO BID	NO BID	
214			4" Diameter	NO BID	40.76	NO BID	NO BID	
215			4" Diameter	NO BID	40.76	NO BID	NO BID	

See Page 20 for Notes Section

OFFICIAL TALLY SHEET

NIAGARA FALLS WATER BOARD BID #W2023-01 WATER AND SEWER CONSTRUCTION AND REPAIR MATERIALS SET 2 OF 2

OPENING DATE: WEDNESDAY, JULY 12, 2023 AT 10:00 AM

Page 20 of 20

**NOTES:**

- EJP: <sup>8</sup>Quoting 20 ft lengths --- Item #32 -38  
<sup>9</sup>Quoting 21" diameter --- Item #200
- K&S Contractors Supply: <sup>10</sup>Quoting BBVB 878 5-1/4" LID ONLY --- Item #19
- Ti Sales: <sup>11</sup>Quoting Ford BBAA --- Item #95-100  
<sup>12</sup>Quoting Ford Q --- Item #111-122  
<sup>13</sup>Quoting Ford B --- Item #145-151  
<sup>14</sup>Quoting Ford C --- Item #152-155  
<sup>15</sup>Quoting Smith-Blair 421 Non Domestic--- Item #159-163

No bids received for Item # 53, 102, 140, 175, and 200.



**INSTALLATION OF ADDITIONAL  
CHLORINE GAS DETECTORS AT WATER TREATMENT PLANT**

**WHEREAS**, part of the process that the Niagara Falls Water Board’s Water Treatment Plant (“WTP”) uses to produce safe drinking water is disinfection using gaseous chlorine which is received and stored in one-ton cylinders; and

**WHEREAS**, among the safety systems in place to prevent injury in the event of an accidental chlorine release is a gas detection and alarm system; and

**WHEREAS**, EPA contractors inspected the chlorine system at the WTP and recommended installation of additional chlorine gas detectors in basement areas of the WTP where gas lines run as an enhancement to the existing safety measures, and Water Board staff agreed with that recommendation; and

**WHEREAS**, the Water Board has procured additional chlorine sensors which are compatible with its gas detection and alarm system and Water Board staff initially anticipated performing the necessary wiring and installation work using in-house resources, but subsequently have advised that due to certain complexities associated with running necessary conduit and wiring, which will require long runs, core drilling, and working at height and among other pipes, wires, and obstructions, that a contractor’s services would be required to complete the installation in a timely manner; and

**WHEREAS**, the Water Board has obtained a quote from Ferguson Electric Co., Inc., dated August 14, 2023 to provide the necessary installation work, including installation of conduit and wiring pursuant to the previously bid indefinite delivery/indefinite quantity (“IDIQ”) electrical work contract that was awarded to that firm;

\* CONTINUED ON NEXT PAGE \*

**NOW THEREFORE BE IT**

**RESOLVED**, that on behalf of the Niagara Falls Water Board, its Executive Director hereby is authorized to pay to Ferguson Electric Co., Inc., an amount not to exceed \$41,000 to perform the wiring, conduit installation, and other tasks necessary for the installation of additional chlorine gas detectors described in that firm’s August 14, 2023 quotation.

*Water Board Personnel Responsible for Implementation of this Resolution:*  
Executive Director

*Water Board Budget Line or Capital Plan Item with Funds for this Resolution:*  
Capital Plan Line: WTP 6.1 – WTP Chlorine System Upgrades  
Capital Line Supplied by: D. Williamson  
Budget Line Confirmed by: B. Majchrowicz

On September 25, 2023, the question of the adoption of the foregoing Resolution was duly put to a vote on roll call, which resulted as follows:

	<b>Yes</b>	<b>No</b>	<b>Abstain</b>	<b>Absent</b>
Board Member Asklar	[ ]	[ ]	[ ]	[ ]
Board Member Kimble	[ ]	[ ]	[ ]	[ ]
Board Member Larkin	[ ]	[ ]	[ ]	[ ]
Board Member Leffler	[ ]	[ ]	[ ]	[ ]
Chairman Forster	[ ]	[ ]	[ ]	[ ]

Signed By:

Vote Witnessed By:

\_\_\_\_\_  
Nicholas J. Forster, Chairman

\_\_\_\_\_  
Sean W. Costello, Secretary to Board

**Design and Engineering**

- Design Build
- High, Medium & Low Voltage Retrofit
- Power System Studies
- Power Quality Solutions
- Energy Audit

**Pre-Construction**

- CAD, Revit, BIM & 3D
- Preliminary Budget
- One-Line Diagram Creation & Maintenance

**Construction Division**

- Distribution
- Branch Power
- Lighting
- Controls
- Project
- Management
- Substation
- 24 Hour Emergency Service

**Line Crew Division**

- Traffic / Signal Installation
- Pole Removal, Relocation, and Installation
- Overhead Line Installation
- Substation

**Service Division**

Your exclusive TEGG® Service provider

- Electrical preventative maintenance programs
- 24-hour emergency service
- Troubleshooting and repair

**Systems Division**

- Data
- Communication
- Fire Alarm
- Security

August 14, 2023

Niagara Falls Water Board  
Municipal Water Plant  
5815 Buffalo Avenue  
Niagara Falls, NY 14304

Attention: Mr. Russell DeFranco

Re: Water Treatment Facility – Chlorine System  
Proposal FE002792

Dear Mr. DeFranco,

We are pleased to submit this proposal for the installation of the Chlorine System at the Water Treatment Facility.

We will:

- Install the Customer supplied sensors and panels.
- Furnish and install the conduit and necessary conductors.
- Provide power to each panel.
- Assist with startup.

Our price for the above is **FORTY-ONE THOUSAND DOLLARS (\$41,000.00)**.

Our price is subject to all applicable sales tax unless otherwise directed by your order to proceed. Our price is based on performing the work during straight-time hours, 7:00 a.m. – 3:30 p.m., Monday through Friday, excluding Sundays or holidays.

Notes:

- We will perform all work strictly according to Article 70E of the NFPA dealing with the Arc Flash Protection.

We appreciate the opportunity to work with the **Niagara Falls Water Board**.

We await your written authorization of acceptance so that we may begin work on this project in a timely, satisfactory manner.

If there are questions, please do not hesitate to contact me.

Respectfully Submitted,

**FERGUSON ELECTRIC INC.**



Daniel R. Schultz  
Manager, Service Division

*NIAGARA FALLS WATER BOARD RESOLUTION # 2023-09-006*

**RENEWAL OF PROPERTY,  
LIABILITY, AND UMBRELLA INSURANCE POLICIES**

**WHEREAS**, the Niagara Falls Water Board, in order to manage risks and to protect the entity against losses from accidents and disasters, secures insurance policies for loss to property and for various liability exposures; and

**WHEREAS**, the Water Board's current property, liability, and umbrella policies expire on October 18, 2023; and

**WHEREAS**, USI, the Water Board's insurance broker, presented an insurance proposal dated September 20, 2023 for these coverages for the October 18, 2023 to October 18, 2024 policy period; and

**WHEREAS**, the total estimated premium for the insurance policies recommended by USI is \$630,761;

\* CONTINUED ON NEXT PAGE \*

**NOW THEREFORE BE IT**

**RESOLVED** that on behalf of the Niagara Falls Water Board, the Executive Director hereby is authorized to accept the September 20, 2023 insurance proposal from USI and to pay to the underwriting companies the premiums therefor, with a total estimated premium of \$630,761.

*Water Board Personnel Responsible for Implementation of this Resolution:*  
Executive Director

*Water Board Budget Line or Capital Plan Item with Funds for this Resolution:*  
FA 0432.000/GA 0432.000 (Property Insurance)  
FA 0433.000/GA 0433.000 (Liability Insurance)  
Budget Line Provided by: B. Majchrowicz  
Available Funds Confirmed by: B. Majchrowicz Note: Balance of premium will be paid from 2023 budget.

*Water Board Personnel Responsible for Implementation of this Resolution:*  
Executive Director

*Water Board Budget Line or Capital Plan Item with Funds for this Resolution:*  
Not applicable

On September 25, 2023, the question of the adoption of the foregoing Resolution was duly put to a vote on roll call, which resulted as follows:

	<b>Yes</b>	<b>No</b>	<b>Abstain</b>	<b>Absent</b>
Board Member Asklar	[ ]	[ ]	[ ]	[ ]
Board Member Kimble	[ ]	[ ]	[ ]	[ ]
Board Member Larkin	[ ]	[ ]	[ ]	[ ]
Board Member Leffler	[ ]	[ ]	[ ]	[ ]
Chairman Forster	[ ]	[ ]	[ ]	[ ]

Signed By:

Vote Witnessed By:

\_\_\_\_\_  
Nicholas J. Forster, Chairman

\_\_\_\_\_  
Sean W. Costello, Secretary to Board

---

**From:** Timothy Wroblewski <Timothy.Wroblewski@usi.com>  
**Sent:** Thursday, September 21, 2023 9:55 AM  
**To:** Sean Costello  
**Cc:** Linda Mayflower  
**Subject:** 23-24 NFWB Proposal  
**Attachments:** 23-24 NFWB Proposal.pdf

**CAUTION:**This email originated from outside of the organization. Do not click links or open attachments unless you recognize the sender and know the content is safe.

Good Morning Mr. Costello,

USI Insurances Services is pleased to present for your review and consideration the attached 2023-2024 Niagara Falls Water Board Insurance renewal presentation.

As we have already discussed and after an extensive marketing effort ( outlined in the presentation attached) , we again are recommending that NFWB renews its 2023-2024 insurance program with Zurich Insurance. Zurich's renewal terms are by far the most competitive and comprehensive of all the markets approach on the NFWB's behalf, so we are recommending them again this year, for your 2023-2024 renewal.

While you and I covered most of your questions and concerns as outlined in your August 21<sup>st</sup> e-mail when we last spoke, there were two items that I believe we did not touch on that I wanted to clarify:

- 1) Cyber Exclusion Endorsement: Zurich was offering very minimal cyber coverage with-in the Zurich coverage forms. The minimal coverage that was being afforded and now excluded by way of endorsement is all covered in your stand-alone Cyber Policy.
- 2) Increased Property values... You will note that in this year's property form that the total property blanket limit is: \$324,154,806.00, up from the expiring policy limit of \$322,436,906.00 for an increase of \$1,717,900.00. The Valuation stays that same: Replacement Cost/ Agreed Value.

Coverages to consider:

- 1) Physical damage on your vehicles. To obtain a quote for your consideration to add these coverages to your vehicles we would need the "cost new" of the vehicles that you may want to place this coverage on. I.E. vehicles that are 5 years old or newer or maybe your higher valued vehicles. We can discuss this further and certainly endorse your policy mid-term should this be a direction that you want to consider.
- 2) Inland Marine/Mobile equipment. Like the auto we would need a list of your mobile equipment to include year, make, models, serial number and values of the equipment that you might want to consider placing physical damage coverage on. Maybe a starting point would be mobile equipment with values starting at \$20,000.00.

After you have had a chance to review our attached proposal...please call or e-mail me with any questions that you or any member of your team may have.

Also.. Linda Mayflower will be e-mailing you shortly with the paperwork that will need to be to be signed to bind coverage.

Thanks again Mr. Costello for your continued partnership with our USI team.

Timothy M. Wroblewski

Vice President

**USI Insurance Services**

726 Exchange Street, Suite 600, Buffalo, NY 14210

Direct: 716.314.2107 | Cell: 716.432.7241

[Timothy.Wroblewski@usi.com](mailto:Timothy.Wroblewski@usi.com) | [www.usi.com](http://www.usi.com)



VISIT OUR [COVID-19 RESOURCE CENTER](#) TO LEARN HOW USI IS HELPING CLIENTS AND COMMUNITIES PREPARE AND RESPOND.



This e-mail and any files transmitted with it may contain confidential and/or privileged material. This e-mail is intended solely for the use of the individual or entity to whom it is addressed. If you are not the intended recipient or have received this e-mail in error, please notify the sender by replying to the sender. After notifying the sender of the error, you should immediately delete this e-mail from your system. Please be aware that any unauthorized disclosure, dissemination, distribution, duplication or use of the e-mail contents or any attachments therein is strictly prohibited.



# Insurance Proposal

September 20, 2023

This is a coverage summary, not a legal contract. This summary is provided to assist in your understanding of your insurance program. Please refer to the actual policies for specific terms, conditions, limitations and exclusions that will govern in the event of a loss. Specimen copies of all policies are available for review prior to the binding of coverage.

Higher limits and additional coverage may be available. Please contact us if you are interested in additional quotes.

Client Name	Niagara Falls Water Board	USI Account Manager:	Linda A. Mayflower, ACSR, CPIA
Mailing Address	5815 Buffalo Avenue Niagara Falls, NY 14304	Phone Number:	716-314-2060
		Email:	Linda.Mayflower@usi.com

**Named Insured:** Niagara Falls Water Board

**Policy Type:** Package, Professional, Umbrella

**Proposed Policy Term:** 10/18/2023 – 10/18/2024      **Quote Expires:** 10/18/2023

**Insurance Carrier:** Zurich

**Carrier Financial Rating:** A+       **Carrier Admitted**       **Carrier Non-Admitted**

**Minimum Earned Premium, if applicable** \_\_\_\_\_ **Policy Subject to Audit**

**Summary of Proposed:** See attached Carrier Proposal

**Total Estimated Premium:** \_\_\_\_\_ **Terrorism included**

- |  |  |  |
|--|--|--|
| <b>Requirements to Effect Coverage</b> | <input checked="" type="checkbox"/> <b>Signed Application</b>  | <input type="checkbox"/> <b>Payment in full or completed premium finance agreement</b> |
|  | <input type="checkbox"/> <b>Signed Terrorism Disclosure Notice</b>                                     | <input type="checkbox"/> <b>Make check payable to: PAYABLE NAME</b>                    |
|  | <input type="checkbox"/> <b>Signed Carrier Rating Notification if financial rating is less than A-</b> | <input checked="" type="checkbox"/> <b>Authorization to order coverage</b>             |
|  | <input type="checkbox"/> <b>Signed Surplus Lines Disclosure and Acknowledgement</b>                    | <input type="checkbox"/> <b>Verification of Named Insured</b>                          |

### Other Information

Other exclusions and policy limitations may apply. Please refer to the actual policies for specific terms, conditions, limitations and exclusions that will govern in the event of a loss. We can provide coverage for such items such as, but not limited to: flood, earthquake, wind, crime and cyber liability.

In evaluating your exposure to loss, we have been dependent upon information provided by you. If there are other areas that need to be evaluated prior to binding of coverage, please bring these areas to our attention. Should any of your exposures change after coverage is bound, such as your beginning new operation, hiring employees in new states, buying additional property, etc., please let us know so proper coverage(s) can be discussed.





## Important Provisions

Building Vacancy Provision – Coverage may be restricted or excluded for any Building found to be vacant for a minimum of 30 consecutive days or longer subject to all other policy terms and conditions. If any of your covered buildings meet this description **at any time during the policy period**, please contact us so we can assist you in maintaining appropriate coverage.



## USI Disclosures

**COMMISSION DISCLOSURE POLICY:** As a licensed insurance producer, USI is authorized to confer with or advise our clients and prospective clients concerning substantive benefits, terms or conditions of insurance contracts, to sell insurance and to obtain insurance coverages for our clients. Our compensation for placement of insurance coverage, unless otherwise specifically negotiated and agreed to with our client, is customarily based on commission calculated as a percentage of the premium collected by the insurer and is paid to us by the insurer. We may also receive from insurers and insurance intermediaries (which may include USI affiliated companies) additional compensation (monetary and non-monetary) based in whole or in part on the insurance contract we sell, which is contingent on volume of business and/or profitability of insurance contracts we supply to them and/or other factors pursuant to agreements we may have with them relating to all or part of the business we place with those insurers or through those intermediaries. Some of these agreements with insurers and/or intermediaries include financial incentives for USI to grow its business or otherwise strengthen the distribution relationship with the insurer or intermediary. Such agreements may be in effect with one or more of the insurers with whom your insurance is placed, or with the insurance intermediary we use to place your insurance. You may obtain information about the nature and source of such compensation expected to be received by us, and, if applicable, compensation expected to be received on any alternative quotes pertinent to your placement upon your request.



## AM Best Disclosures

Changes in the international insurance market have affected the ability of insurance brokers to locate insurance coverage at a scope and cost of insurance placed in prior years. Some insurance carriers have suffered significant losses that may jeopardize their financial stability. Changes in an insurance company's financial condition can, of course, affect its ability to pay claims.

As a matter of policy, USI endeavors to obtain quotations and indications from insurance companies who meet or exceed the USI minimum guidelines of A- based on the A. M. Best Ratings of insurance companies. The A.M. Best Company is a recognized publisher of information concerning insurers based on many factors including financial stability. [A. M. Best's current rating scale is attached.](#)



# Insurance Carrier Ratings

As a service to our clients, USI is furnishing an assessment by a financial rating service of the insurance companies included in our proposal. We are including the legends used by this service.

All ratings are subject to periodic review, therefore, it is important to obtain updated ratings from each service. Should you desire further information concerning the financial statements of any of the insurance companies being proposed, so that you can make your own assessment of the financial strength of the companies being offered, it is available from USI at your request.

USI has made no attempt to determine independently the financial capacity of the insurance companies that we are including in our proposal as we believe the nationally recognized services are better equipped to comment.

## A. M. BEST RATINGS

<b>A++ and A+</b>	Superior	<b>B and B-</b>	Fair
<b>A and A-</b>	Excellent	<b>C++, C+</b>	Marginal
<b>B++, B+</b>	Very Good	<b>C and C-</b>	Weak
<b>D</b>	Poor	<b>F</b>	In Liquidation
<b>E</b>	Under Regulatory Supervision	<b>S</b>	Rating Suspended

## FINANCIAL SIZE CATEGORY

(In \$ Thousands)

Class	I	Less than		1,000
Class	II	1,000	to	2,000
Class	III	2,000	to	5,000
Class	IV	5,000	to	10,000
Class	V	10,000	to	25,000
Class	VI	25,000	to	50,000
Class	VII	50,000	to	100,000
Class	VIII	100,000	to	250,000
Class	IX	250,000	to	500,000
Class	X	500,000	to	750,000
Class	XI	750,000	to	1,000,000
Class	XII	1,000,000	to	1,250,000
Class	XIII	1,250,000	to	1,500,000
Class	XIV	1,500,000	to	2,000,000
Class	XV	2,000,000	to	or greater

## RATING "NOT ASSIGNED" CLASSIFICATIONS

<b>NR-1</b>	Insufficient Data	<b>NR-2</b>	Insufficient Size and/or Operating Experience
<b>NR-3</b>	Rating Procedure Inapplicable	<b>NR-4</b>	Company Request
<b>NR-5</b>	Not Formally Followed		



<b>Coverage</b>	<b>2022-23 Premium</b>	<b>2023-24 Premium</b>
Package – Total	\$432,362	\$504,069
Professional Liability	\$70,501	\$64,315
Umbrella	\$70,225	\$62,377
<b>Total</b>	<b>\$573,088</b>	<b>\$630,761</b>



## Marketing Efforts

Company	Market Response
HCC/US Specialty	Property values are an issue. HCC/US Specialty not willing to provide the Property limits being requested which would force us to place a secondary layer of property coverage to secure adequate limits, which of course comes with additional premium. Coverages for the casualty are comparable to Zurich but TIV is too high at this point. Also, in discussion with the HCC/ US Specialty underwriters, pricing would not be competitive with current or proposed Zurich renewal premium.
Homesite Insurance	Max Liability limits offered \$5 million (Zurich at a total of \$11,000,000) – Also this program is written with a self-insured minimum \$100,000 retention basis only, versus Zurich’s which is on a deductible basis. Also, Homesite is no longer writing property/breakdown boiler coverage which would cause us to pursue a stand-alone property coverage making this arrangement not competitive to the Zurich renewal term.
Old Republic	Can only consider self-insured \$250,000 retention, not a deductible basis, and cannot provide pollution, asbestos and lead exceptions like Zurich policy. Also, failure to supply limit may not be extended beyond \$1 million. The form is an indemnification not a duty to defend form. Insured would have to contract with an approved TPA at their own expense to handle the claims within the SIR. Not a competitive option to the Zurich Renewal terms.
Berkley	Can only entertain a total of \$5 million liability and professional limits, no property/boiler (and finding stand-alone property carrier in this market is difficult) Self Insured retention basis only. Not a viable or competitive option to the Zurich renewal terms.

In summary... our marketing efforts for this year’s renewal insurance program has presented options, but it is clear all of them would have come at much higher premium levels and a considerable amount of coverage reductions as compared to the Zurich Program.



**ZURICH**<sup>®</sup>

**MUNIPLUS™ PROPOSAL  
PACKAGE/PROFESSIONAL/UMBRELLA  
NIAGARA FALLS WATER BOARD & NIAGARA FALLS PUBLIC**

**ISSUE DATE:** 9/19/2023  
**VALID THROUGH:** 10/17/2023  
**INSURED:** Niagara Falls Water Board & Niagara Falls Public  
**TERM:** 10/18/2023 to 10/18/2024

**UNDERWRITING COMPANY:**

Primary Package (Property, Crime, General Liability, Auto) Zurich American Insurance Company (Admitted Paper) AM Best Rating A+ XV  
Primary Professional Liability (Public Officials, EPL): Zurich American Insurance Company (Admitted Paper) AM Best Rating: A+ XV  
Umbrella: Zurich American Insurance Company (Admitted Paper) AM Best Rating: A+ XV

**PREMIUM AND PAYMENT TERMS\*\*:**

Package Premium: **	\$489,023.00
Professional Premium:	\$64,315.00
Umbrella Premium:	\$61,759.00
Subtotal Premium without TRIA:	<u>\$615,097.00</u>
Property TRIA Premium:	\$8,666.00
Liability TRIA Premium:	\$622.00
Umbrella TRIA Premium:	\$618.00
Risk Engineering Resources Fee	\$250.00
NY Motor Vehicle Fee	\$330.00
NYFF	\$5,178.46
<b>TOTAL PREMIUM (incl. TRIA/Fees)</b>	<u><u>\$630,761.46</u></u>

**LIMITS and DEDUCTIBLES:** See attached

---

“This proposal is based on the inclusion of all stated coverages and the terms and conditions related to those coverages. Any requested changes to the coverage requested or to any other terms and conditions will require an amended proposal showing all revised provisions.”

*\*\*Premium is due at inception, payable in 30 days. Any state surcharges and fees are in addition to and not considered premium.*

**COVERAGE SUMMARY OF LIMITS, DEDUCTIBLES & RETENTIONS:**

<b>LINES OF BUSINESS (Sublines/Sublimits)</b>	<b>LIMIT</b>	<b>AGGREGATE</b>	<b>DEDUCTIBLE/ RETENTIONS</b>	<b>COVERAGE TRIGGER</b>
<b>Property (Valuation- Replacement Cost)</b>	\$324,154,806	Blanket	See Exhibit A	Occurrence
<b>See Exhibit A</b>				
<b>Equipment Breakdown</b>				
Property Damage (PD)	\$100,000,000	N/A	See Property Deductible	Occurrence
Spoilage	\$100,000 per Occurrence	N/A	See Property Deductible	Occurrence
Expediting Expense	Included in Property Extra Expense Limit	N/A	See Property Deductible	Occurrence
Pollutant Clean Up & Removal	Included in Property	\$250,000	See Property Deductible	Occurrence
Service Interruption	Included in Property Business Interruption /Extra Expense	N/A	See Property Deductible	Occurrence
<b>Crime</b>				
Employee Theft—Per Loss	\$100,000	Included	\$5,000	Occurrence
Theft, Disappearance & Destruction				
Inside	\$25,000	Included	\$5,000	Occurrence
Outside the Premises	\$25,000	Included	\$5,000	Occurrence
Faithful Performance	Included	Included	\$5,000	Occurrence
<b>Auto Liability</b>	\$1,000,000	CSL	\$100,000	Accident
<b>See Exhibit B</b>				
Personal Injury Protection (KY, NY, PA)	Included	N/A	N/A	Accident
Medical Payments (except KY)	\$10,000	N/A	N/A	Accident
Uninsured Motorist	\$50,000	N/A	N/A	Accident
Underinsured Motorist	\$50,000	N/A	N/A	Accident
Hired Auto Liability	\$1,000,000	N/A	N/A	Accident
Non-Owned Auto Liability	\$1,000,000	N/A	N/A	Accident



<b>LINES OF BUSINESS (Sublines/Sublimits)</b>	<b>LIMIT</b>	<b>AGGREGATE</b>	<b>DEDUCTIBLE/ RETENTIONS</b>	<b>COVERAGE TRIGGER</b>
<b>General Liability</b>	\$1,000,000	\$3,000,000	\$100,000	Occurrence
<b>See Exhibit B</b>				
Damage to Property Rented to You	\$1,000,000 (any one premises)	Included	\$100,000	Occurrence
Medical Benefits	\$10,000 (any one person)	Included	N/A	Occurrence
Personal & Advertising Injury	\$1,000,000 (any one person or organization)	Included	\$100,000	Occurrence
Products Completed Operations	\$1,000,000	\$3,000,000	\$100,000	Occurrence
Employee Benefits Liability	\$1,000,000	\$3,000,000	\$1,000	Occurrence
<b>Public Officials Liability</b>				
<b>Retroactive Date: 1/1/1999</b>	\$1,000,000	\$3,000,000	\$100,000	Claims Made
<b>See Exhibit C</b>				
Non-Monetary	\$25,000	\$25,000	N/A	Claims Made
Crisis Management	\$5,000	\$5,000	N/A	Claims Made
<b>Employment Practices Liability</b>				
<b>Retroactive Date: 1/1/1999</b>	\$1,000,000	\$3,000,000	\$100,000	Claims Made
<b>See Exhibit C</b>				
<b>Umbrella</b>	\$10,000,000	\$10,000,000	\$10,000 SIR	Follows Underlying

**ALLIED PUBLIC RISK**  
**EXHIBIT A – PROPERTY COVERAGE PART**  
**PROPOSED INSURED: Niagara Falls Water Board & Niagara Falls Public**

PROPERTY COVERAGE PART			
<b>Insured:</b>	Niagara Falls Water Board & Niagara Falls Public	<b>State:</b>	NY
<b>Covered Locations:</b>	Per Statement of Values: Blanket coverage applies unless otherwise noted		
<b>Coinsurance:</b>	90%		
<b>Valuation:</b>	Replacement Cost/Agreed Value	<b>Form:</b>	Special Form (including theft)

LIMITS	DEDUCTIBLE	COVERAGES (All coverage listed below applies per occurrence.)
\$324,154,806	\$50,000	<b>Buildings</b>
Included	Per Policy Deductible	<b>Business Personal Property</b>
Included in Building Limit	\$50,000	<b>Pump and Lift Stations</b>
\$5,000,000	2.00%	<b>Earthquake (A percentage deductible applies separately to each building or contents limit not to exceed \$100,000)</b>
\$5,000,000	\$100,000	<b>Flood (Only available for Zone C and X (Unshaded)), X500, B, and X (shaded))</b> Zurich/APR cannot warrant or provide information as to what zone(s) a specific location/address is situated in. Flood zones can and do change. It is ultimately the responsibility of the insured and their insurance advisor to determine if the flood zones and flood limits proposed are adequate for their needs.
Not quoted	N/A	<b>Named Storm Deductible – Minimum Deductible of N/A</b>
Included in Building Limit	Per Policy Deductible	<b>Equipment Breakdown</b>

PUBLIC ENTITY ADDITIONAL COVERAGES AND COVERAGE EXTENSIONS			
LIMITS	DEDUCTIBLE	ADDITIONAL COVERAGE	
Included in Building Limit	Per Policy Deductible	<b>Collapse</b> -Abrupt collapse of a building or covered property. ISO Causes of Loss – Special Form	
25% of direct physical loss of or damage to covered property plus the deductible in the policy applicable to that loss or damage.	Per Policy Deductible	<b>Debris Removal</b> - We will pay for your expense to remove debris of Covered Property caused by or resulting from a Covered Cause of Loss that occurs during the policy period. The expenses will be paid only if they are reported to us in writing within <b>180 days</b> .	
\$300,000 Per Location/Per Occurrence	Per Policy Deductible	<b>Additional Debris Removal Expense</b> – eligible if one or both of the explained circumstances apply.	
\$50,000	No Deductible	<b>Fire Department Service Charge</b> - Provides coverage for your liability for fire department service charges when the fire department is called to save or protect your covered property.	
\$250,000	Per Policy Deductible	<b>Pollutant Clean up and Removal</b> - During each separate 12 month period	
\$500,000 Per Occurrence	\$500 Deductible	<b>Accounts Receivable</b> (Per Occurrence Premises Limit)	
\$15,000 per animal	\$500 Deductible	<b>Animal Mortality</b>	<b>Coverage is provided for loss caused by the death or destruction of your animals used for police department canine or equestrian patrol. \$100,000 annual aggregate</b>
Included in Business Personal Property Limit	Per Policy Deductible	<b>Building Glass - Tenant</b>	
Included in the Building Limit	Per Policy Deductible	<b>Building Ordinance or Law Coverage</b>	Coverage A (Undamaged Building Coverage)
\$1,000,000 per building/per loss	Per Policy Deductible		Coverage B (Demolition)
	Per Policy Deductible		Coverage C (Increased Cost of Construction)

**ALLIED PUBLIC RISK**  
**EXHIBIT A – PROPERTY COVERAGE PART**  
**PROPOSED INSURED: Niagara Falls Water Board & Niagara Falls Public**

LIMITS	DEDUCTIBLE	ADDITIONAL COVERAGE
\$1,000,000 per occurrence	Per Policy Deductible	<b>Business Income and Extra Expense</b> – Including Relocation Expenses and Costs to Equip and Operate the Replacement or Temporary Location, Civil Authority, Alterations and New Buildings, Extended Business Income up to 60 days, Interruption of Computer Operations and Food Contamination.
\$100,000	Per Policy Deductible	<b>Food Contamination</b> (Annual Aggregate Limit of Insurance)
\$100,000		<b>Newly Acquired Location</b> (Limit of Insurance Per Occurrence)
\$100,000		<b>Utility Services Time Element</b> (Limit of Insurance Per Occurrence)
\$100,000		<b>Sales Tax Revenue Loss</b> (Limit of Insurance Per Occurrence)
Increased Period to Comply with Ordinance or Law	No Deductible	<b>Period of Restoration</b>
\$50,000 any one occurrence	Per Policy Deductible	<b>Electrical Utility Service Interruption – Direct Damage</b>
\$10,000 Per Item \$100,000 Per Loss	\$500 Deductible	<b>Fine Arts</b> - Per Item and Per Loss Limit
\$25,000 annual aggregate	Per Policy Deductible	<b>Fire Protective Device Recharge</b>
Included in Building Limit	Per Policy Deductible	<b>Foundations, Underground Pipes, Flues or Drains</b> within 1,000 feet of described premises
\$100,000 any one occurrence \$5,000 maximum per item	\$500 Deductible	<b>Grounds Maintenance Equipment</b>
\$25,000 per occurrence	No Deductible	<b>Inventory Costs, Preparation of Claim</b>
\$2,000,000 each building \$1,000,000 contents	Per Policy Deductible	<b>Newly Acquired or Constructed Property</b> - Each Building Limit/Contents Limit
\$20,000	Per Policy Deductible	<b>Non-Owned Detached Trailers</b>
\$250,000 per location per occurrence	Per Policy Deductible	<b>Outdoor Property (specific perils)</b> - includes but not limited to Fences, Park Benches, Flagpoles, Communication Towers, Golf Course Greens, etc.
\$100,000 per loss	Per Policy Deductible	<b>Paved Surfaces (limited perils)</b>
\$25,000 each described premises	Per Policy Deductible	<b>Personal Effects and Property of Others</b>
\$100,000 per occurrence	\$500 Deductible	<b>Portable Audio Visual and Communications Equipment</b>
\$100,000	\$500 Deductible	<b>Portable Emergency Response Equipment</b>
\$100,000 per occurrence	\$500 Deductible	<b>Portable Equipment Used in Your Law Enforcement Operations and Your Public Safety Operations</b>
1,000 Ft.	Per Policy Deductible	<b>Premises Boundary Increase Distance</b>
\$100,000 per Occurrence	Per Policy Deductible	<b>Property Off-Premises Including Transit</b> (including property at fairs, trade shows and exhibitions)
\$100,000 per occurrence	Per Policy Deductible	<b>Sewer Backup</b>
\$100,000 each described premises	Per Policy Deductible	<b>Theft of Building Materials and Supplies</b>
\$100,000 per occurrence	\$500 Deductible	<b>Traffic Lights, Traffic Signs, Parking Meters, Fire Hydrants, Guard Rails, Bus Shelters</b>
\$500,000 each described premises	\$500 Deductible	<b>Valuable Papers and Records</b> (Other than Electronic Data) 1,000 feet of described premises

**ALLIED PUBLIC RISK (NEW YORK)**  
**EXHIBIT B –GENERAL LIABILITY AND COMMERCIAL AUTOMOBILE COVERAGE PARTS**  
**PROPOSED INSURED: Niagara Falls Water Board & Niagara Falls Public**

<b>General Liability Coverage Part</b>	
<b>Limits</b>	<b>Coverage Enhancement</b>
\$1,000,000	Sexual Abuse/Molestation Limit - \$100,000 Retention
\$1,000,000	Sexual Abuse/Molestation Aggregate
Included	Broad Governmental-Specific Definition of Insured
Included	Employees/Volunteers as Insureds
Included	Watercraft Liability (up to 51 feet)
Included	Good Samaritan Liability
Included	Herbicide / Pesticide Application
Included	Host Liquor Liability
Included	Broadened Contractual Liability
Included	Limited Contractual Liability for Personal Injury
Included	Broadened Property Damage Liability
Included	Broadened Pollution for Municipal Exposures (including herbicides/ pesticides, swimming pool maintenance, water and sewer operations, salt)

<b>Limits</b>	<b>Coverage Enhancement</b>
\$1,000,000	Failure to Supply
Included	Pollution exceptions for Potable Water Operations
Included	Use of Chemicals, Gas or Propane in your Water Operations
Included	Escape or Back-up from the Treatment Facility or Insured's Piping
Included	Elimination of Asbestos and Lead Exclusion wording relating to Potable Water

**ALLIED PUBLIC RISK (NEW YORK)**  
**EXHIBIT B –GENERAL LIABILITY AND COMMERCIAL AUTOMOBILE COVERAGE PARTS**  
**PROPOSED INSURED: Niagara Falls Water Board & Niagara Falls Public**

<b>New York Commercial Automobile See Schedule of Vehicles</b>		<b>Number of Vehicle Units Quoted 44</b>
<b>Limits</b>	<b>Coverage</b>	
Included	Employees and Volunteers as Insureds	
Not Included	Mutual Aid	
Not Included	Supplemental Spousal	
Included	Fellow Employee Coverage	

## Public Officials Liability

### Coverage Features:

Claims Made and Reported Form

Defense in Addition to Limit

Sublimit for Defense for Non-Monetary claims

Modified Consent to Settle Clause with hammer clause at only 50% participation

Includes a broad definition of Loss including: **Punitive Damages, Exemplary Damages or Multiple Damages**, where insurable under applicable law. Most favorable jurisdiction wording applies.

Civil Rights coverage is provided.

Crisis Event coverage for public officials is provided.

## Employment Practices Liability

### Coverage Features:

Claims Made and Reported Form

Defense in Addition to Limit

Third Party Discrimination Liability is included (harassment provided)

Civil Right coverage is provided

Crisis Event Coverage is provided

Business invitee (Third Party) Liability covering Emotional Distress, Sexual Harassment, Discrimination and other allegations

Broad definition of Claim including coverage for regulatory proceedings, arbitration hearings and EEOC hearings, subject to exclusions

Includes a broad definition of Loss including: **Punitive Damages, Exemplary Damages or Multiple Damages**, where insurable under applicable law. Most favorable jurisdiction wording applies.

## POLICY CONDITIONS

**TERRITORY:** United States and its territories or possessions

**NON-AUDITABLE:** The Policy is not subject to audit

**GENERAL CONDITIONS:**

- Coverage is not auditable, except in New York.
- The Business Auto Coverage requires 17-digit VIN numbers. The insured's policy cannot be released without this information.
- We require that the insured perform MVR reviews annually on all drivers and prior to hiring new drivers. By accepting this insurance policy, the insured confirms they have in place or agrees to adopt driver selection procedures and safe driving standards that include specific violation conditions indicating when an employee will not be allowed to operate entity vehicles or motorized equipment. These procedures will be subject to loss control review.
- Provide list of all Additional Insured - Loss Payees including their insurable interest for Auto and Property Exposures.
- Claim Reporting - American Claims Management - 877-233-4470. E-mail: [NewLossesCL@acmclaims.com](mailto:NewLossesCL@acmclaims.com). Fax: 760-827-4844. Mail: American Claims Management, PO Box 9060, Carlsbad, CA 92018-9060. Website: [www.ACMclaims.com](http://www.ACMclaims.com).

**SPECIFIC ADDITIONAL CONDITIONS:**

- 
- 
- 
- 
- 

This quotation represents the Company's proposed terms and conditions, which may not include all of the requested terms and conditions. No warranty is made or implied with respect to the total compliance to bid specifications or applications

## EXCLUSIONS:

Specifically excluded exposures include, *but are not limited to* the following. Please check provided policy specimen forms closely. Specific specimen exclusionary language will be provided upon request.

<b>GENERAL:</b>	Asbestos, Lead, Silica, Nuclear, Nuclear Hazard, Pollution, Fungi/Bacteria, Electromagnetic Radiation, Communicable Disease, War and Military Action, Nuclear Device Detonation, Pathogenic or Poisonous Biological or Chemical Materials, Violation of Economic or Trade Sanctions.
<b>PROPERTY</b>	Exclusions as stated on the Building and Personal Property Coverage Form. Flood does not apply to any location(s) situated in a “special flood coverage area” as determined by the Federal Emergency Management Agency (FEMA). These areas are currently designated by FEMA as zones A, AE, AO, AH, A1-A30, A99, AR, AR/AE, AR/AO, AR/A1-A30, AR/AH, AR/A,V, V1-V30, VE, VO, X500, XFUT, B, XB, and X500 and on a FEMA Flood Rate Map, shaded X. Any area later designated by FEMA as a “special flood coverage area” at the time of a Covered Cause of Loss is also subject to this limitation. Any area removed by FEMA from a “special flood coverage area” designated at the time of a Covered Cause of Loss is not subject to this limitation.
<b>EQUIPMENT BREAKDOWN:</b>	Exclusions as stated on the Equipment Breakdown Endorsement.
<b>INLAND MARINE:</b>	Not Covered
<b>CRIME:</b>	Exclusions as stated on the Crime coverage form.
<b>BUSINESS AUTO/ BUSINESS AUTO PHYSICAL DAMAGE:</b>	Exclusions as stated on the Business Auto Coverage Form, including but not limited to Racing, and the Business Auto Physical Damage Coverage Form.
<b>GENERAL LIABILITY:</b>	Exclusions as stated on the Commercial General Liability Coverage Form including but not limited to: Per- and Polyfluoroalkyl Substances (PFAS) Exclusion, Lead Contamination, Dams, Aircraft, Airport, Mold, Pollution, Asbestos (except as provided for in the Water Enhancement Endorsement), Lead Contamination, Silica, Electronic Data, Electronic Vandalism, Employers Liability (Stop Gap), Law Enforcement, Securities, Underground Storage Tanks, Workers Compensation. Policy excludes fireworks; however, the exclusion can be deleted on a display by display basis supported by the date of display and a copy of the contract with the pyrotechnic company for review.



<b>LAW ENFORCEMENT:</b>	Not Covered
<b>PUBLIC OFFICIALS:</b>	Exclusions as stated on the Public Officials Liability Insurance Policy, including but not limited to: Distribution of Material in Violation of Statutes; Electronic Data; Electric Vandalism; Eminent Domain/Inverse Condemnation; Fiduciary, Financing, Taxes; Fines and Penalties; Fraudulent or Dishonest Acts; Maintain Insurance; Non-Monetary; Professional Services; Prior Notice, Pending or Prior Legal Action; Violations of Laws; Workers Compensation; Securities.
<b>EMPLOYMENT PRACTICES:</b>	Exclusions as stated on the Employment Practices Liability Insurance Policy, including but not limited to: Fiduciary, Employee Benefits, Fraudulent of Dishonest Acts, Labor Disputes, Maintain Insurance, Non-Monetary, Prior Notice, Prior or Pending Legal Action, Violation of Laws, Wage and Hour Law, Workers Compensation.
<b>UMBRELLA:</b>	Exclusions as stated on the Umbrella Coverage form, including but not limited to Per- and Polyfluoroalkyl Substances (PFAS) Exclusion

**THE FOLLOWING ITEMS ARE DUE AT THE TIME OF BINDING:**

- Signed and Dated Public Entity Application, preferably the Allied Public Risk Application.
- Terrorism: Please refer to the attached Policyholder Disclosure Notice of Terrorism Insurance Coverage for the TRIA quote. This Proposal includes coverage for the TRA (Terrorism Risk Insurance Program) Reauthorization Act of 2015. The insured has the option to reject terrorism coverage. If the insured elects to reject the coverage, the attached Disclosure Notice of Terrorism Insurance Coverage must be completed and signed by the insured. If this notice is not returned to us upon binding of coverage, the terrorism premium will automatically be included.
- Signed and Dated Uninsured/Underinsured Motorist Selection /Rejection Form.
- Optional Supplemental Spousal Liability Premium is available. Please refer to the Supplemental Spousal Liability Coverage Selection/Rejection Form for the annual premium. If desired, remit the Signed and Dated Supplemental Spousal Liability Coverage Selection/Rejection Form at time of bind request.
- Copy of the latest Dam Inspection reports and the insureds response to inspection deficiencies if any.
- Signed Statement of Values.
- Insured's FEIN Number.
- Provide Name, Phone Number and Email Address for both the Risk Manager and the Boiler & Machinery Inspection contacts.
- Provide a complete driver schedule including name, date of birth and license number.

ALLIED PUBLIC RISK – STATEMENT OF VALUES  
 Zurich American Insurance Company  
 INSURED: Niagara Falls Water Board & Niagara Falls Public Niagara Falls NY 14304  
 POLICY YEAR EFFECTIVE: 10/18/2023 - 10/18/2024

TRANS TYPE*	LOC ID	BLDG NUM	ADDRESS	BUILDING DESCRIPTION	BUILDING VALUE	CONTENTS VALUE	TOTAL INSURED VALUE	EARTHQUAKE DEDUCTIBLE %
E	1	1	10016 Colvin Bld	Pump Station	\$96,200	\$300,000	\$396,200	25.2398%
E	2	1	1002 Falls Street	Regulator 11A/11B	\$37,500	\$10,000	\$47,500	100.0000%
E	3	1	1124 Military Road	Lift Station	\$22,500	\$15,000	\$37,500	100.0000%
E	4	1	1201 Buffalo Avenue	Sewage Treatment Plant Main Plant	\$165,898,900	\$11,705,000	\$177,603,900	0.0563%
E	4	2	1201 Buffalo Avenue	Sewage Treatment Plant Power Substation	\$10,000	\$0	\$10,000	100.0000%
E	4	3	1201 Buffalo Avenue	Sewage Treatment Plant Storage & Office	\$10,000	\$0	\$10,000	100.0000%
E	4	4	1201 Buffalo Avenue	Sewage Treatment Plant Scum Collection	\$10,000	\$0	\$10,000	100.0000%
E	4	5	1201 Buffalo Avenue	Sewage Treatment Plant Gate House	\$10,000	\$0	\$10,000	100.0000%
E	4	6	1201 Buffalo Avenue	Sewage Treatment Plant Gate House	\$10,000	\$0	\$10,000	100.0000%
E	4	7	1201 Buffalo Avenue	Sewage Treatment Plant Settling Basins	\$10,000	\$0	\$10,000	100.0000%
E	4	8	1201 Buffalo Avenue	Sewage Treatment Plant Settling Basins	\$10,000	\$0	\$10,000	100.0000%

\*Trans type – N-New, E-Existing, M-Modified, PD, Previously Deleted, D-Deleted

ALLIED PUBLIC RISK – STATEMENT OF VALUES  
 Zurich American Insurance Company  
 INSURED: Niagara Falls Water Board & Niagara Falls Public Niagara Falls NY 14304  
 POLICY YEAR EFFECTIVE: 10/18/2023 - 10/18/2024

TRANS TYPE*	LOC ID	BLDG NUM	ADDRESS	BUILDING DESCRIPTION	BUILDING VALUE	CONTENTS VALUE	TOTAL INSURED VALUE	EARTHQUAKE DEDUCTIBLE %
E	4	9	1201 Buffalo Avenue	Sewage Treatment Plant Settling Basins	\$10,000	\$0	\$10,000	100.0000%
E	4	10	1201 Buffalo Avenue	Sewage Treatment Plant Storage	\$10,000	\$0	\$10,000	100.0000%
E	4	11	1201 Buffalo Avenue	Sewager Treatment Plant Storage	\$15,000	\$0	\$15,000	100.0000%
E	5	1	1565 101st Street	Lift Station	\$47,400	\$200,000	\$247,400	40.4204%
E	6	1	1757 Falls Street	Regulator 9	\$18,000	\$10,000	\$28,000	100.0000%
E	7	1	1780 Beech Avenue	Steel Water Tank	\$4,266,700	\$0	\$4,266,700	2.3437%
E	8	1	201 22nd Street	Gas Monitor Station	\$18,000	\$0	\$18,000	100.0000%
E	9	1	215 27th Street	SSI Monitor Station	\$18,000	\$0	\$18,000	100.0000%
E	10	1	227 12th Street	Regulator 10	\$18,000	\$10,000	\$28,000	100.0000%
E	11	1	300 27th Street	Regulator 4A	\$18,000	\$10,000	\$28,000	100.0000%
E	12	1	300 4th Street	Regulator 12	\$18,000	\$10,000	\$28,000	100.0000%
E	13	1	305 Hyde Park	Regulator 6A/6B	\$37,500	\$12,000	\$49,500	100.0000%
E	14	1	315 19th Street	Regulator	\$18,000	\$10,000	\$28,000	100.0000%
E	15	1	315 21st Street	Regulator 3A	\$37,500	\$10,000	\$47,500	100.0000%

\*Trans type – N-New, E-Existing, M-Modified, PD, Previously Deleted, D-Deleted

ALLIED PUBLIC RISK – STATEMENT OF VALUES  
 Zurich American Insurance Company  
 INSURED: Niagara Falls Water Board & Niagara Falls Public Niagara Falls NY 14304  
 POLICY YEAR EFFECTIVE: 10/18/2023 - 10/18/2024

TRANS TYPE*	LOC ID	BLDG NUM	ADDRESS	BUILDING DESCRIPTION	BUILDING VALUE	CONTENTS VALUE	TOTAL INSURED VALUE	EARTHQUAKE DEDUCTIBLE %
E	16	1	315 22nd Street	Regulator 2A/2B	\$18,000	\$12,000	\$30,000	100.0000%
E	17	1	400 30th Street	Regulator 5	\$18,000	\$10,000	\$28,000	100.0000%
E	18	1	440 56th Street	Steel Water Tank	\$4,266,700	\$0	\$4,266,700	2.3437%
E	19	1	4400 Royal Avenue	SSI Monitor Station	\$18,000	\$0	\$18,000	100.0000%
E	20	1	4700 Royal Avenue	SSI Monitor Station	\$18,000	\$0	\$18,000	100.0000%
E	21	1	4800 Pen Street	Gas Monitor Station	\$18,000	\$0	\$18,000	100.0000%
E	22	1	539 Cayuga Drive	Pump Station	\$18,700	\$0	\$18,700	100.0000%
E	23	1	5601 Buffalo Avenue	Lift Station	\$18,000	\$200,000	\$218,000	45.8716%
E	24	1	5815 Buffalo Avenue	Main Water Treatment	\$98,318,585	\$6,583,121	\$104,901,706	0.0953%
E	24	2	5815 Buffalo Avenue	Chlorine Water Treatment	\$5,000	\$0	\$5,000	100.0000%
E	24	3	5815 Buffalo Avenue	Power back-up/Screening Water Treatment	\$5,000	\$0	\$5,000	100.0000%
E	24	4	5815 Buffalo Avenue	Water Treatment Storage	\$5,000	\$0	\$5,000	100.0000%
E	24	5	5815 Buffalo Avenue	Water Treatment Storage	\$5,000	\$0	\$5,000	100.0000%
E	24	6	5815 Buffalo Avenue	Water Treatment Security/Storage	\$5,000	\$0	\$5,000	100.0000%

\*Trans type – N-New, E-Existing, M-Modified, PD, Previously Deleted, D-Deleted

ALLIED PUBLIC RISK – STATEMENT OF VALUES  
 Zurich American Insurance Company  
 INSURED: Niagara Falls Water Board & Niagara Falls Public Niagara Falls NY 14304  
 POLICY YEAR EFFECTIVE: 10/18/2023 - 10/18/2024

TRANS TYPE*	LOC ID	BLDG NUM	ADDRESS	BUILDING DESCRIPTION	BUILDING VALUE	CONTENTS VALUE	TOTAL INSURED VALUE	EARTHQUAKE DEDUCTIBLE %
E	24	7	5815 Buffalo Avenue	Water Treatment/Pump House	\$50,000	\$0	\$50,000	100.0000%
E	25	1	8020 Stephenson Avenue	Lift Station	\$23,000	\$200,000	\$223,000	44.8430%
E	26	1	8025 Frontier Avenue	Lift Station	\$65,000	\$200,000	\$265,000	37.7358%
E	27	1	8090 W. Rivershore	By-Pass Pump Station	\$20,000	\$100,000	\$120,000	83.3333%
E	28	1	8643 Griffin Avenue	Lift Station	\$20,000	\$200,000	\$220,000	45.4545%
E	29	1	920 Whirlpool Street	Gorge Pump Station	\$30,471,500	\$59,000	\$30,530,500	0.3275%
E	30	1	932 91st Street	Lift Station	\$27,000	\$200,000	\$227,000	44.0529%

\*Trans type – N-New, E-Existing, M-Modified, PD, Previously Deleted, D-Deleted

ALLIED PUBLIC RISK –AUTO SCHEDULE  
 Zurich American Insurance Company  
 INSURED: Niagara Falls Water Board & Niagara Falls Public Niagara Falls NY 14304  
 POLICY YEAR EFFECTIVE: 10/18/2023

TYPE ***	AUTO #	YEAR	MAKE	MODEL	COST NEW	COMP DED	COLL DED	VIN	VALUATION
E	1	2018	FORD	F250	\$0	No Coverage	No Coverage	1FT7X2B61JEB73778	Actual Cash Value
E	2	2018	FORD	F250	\$0	No Coverage	No Coverage	1FT7X2B67JEB73669	Actual Cash Value
E	3	2018	FORD	ESCAPE	\$0	No Coverage	No Coverage	1FMCU9GD5JUB76465	Actual Cash Value
E	4	2018	FORD	ESCAPE	\$0	No Coverage	No Coverage	1FMCU9GD7JUB76466	Actual Cash Value
E	5	2018	FORD	ESCAPE	\$0	No Coverage	No Coverage	1FMCU9GD9JUB76467	Actual Cash Value
E	6	2018	FORD	TRANSIT	\$0	No Coverage	No Coverage	NM0LS6E74J1369890	Actual Cash Value
E	7	2017	FORD	F350	\$0	No Coverage	No Coverage	1FDRF3H69HEF40344	Actual Cash Value
E	8	2017	FORD	F250	\$0	No Coverage	No Coverage	1FT7X2B66HEC88404	Actual Cash Value
E	9	2017	FORD	FUSION E	\$0	No Coverage	No Coverage	3FA6POPU5HR148189	Actual Cash Value
E	10	2015	FORD	ESCAPE	\$0	No Coverage	No Coverage	1FMCU0F73FUC81665	Actual Cash Value
E	11	2015	FORD	E250	\$0	No Coverage	No Coverage	1FT7W2B67FED69508	Actual Cash Value
E	12	2015	FORD	F350	\$0	No Coverage	No Coverage	1FT8W3B67FEB07157	Actual Cash Value
E	13	2013	FORD	F250	\$0	No Coverage	No Coverage	1FTBF2B6XDEB30574	Actual Cash Value
E	14	2018	JOHN DEERE	MINI EXCAVATOR	\$0	No Coverage	No Coverage	1FF0356XLJK281945	Actual Cash Value
E	15	2018	WESTERN STAR	BIG RED 4700	\$0	No Coverage	No Coverage	5KKHAVDV4JLJZ2301	Actual Cash Value
E	16	2018	TRAILER KING	TK12U TILT-UTILITY TRAILER	\$0	No Coverage	No Coverage	1TKU02624JR047656	Actual Cash Value

\*\*\*Type Codes E-Existing, N-New, M-Modified, D-Deleted, PD-Previously Deleted

ALLIED PUBLIC RISK –AUTO SCHEDULE  
 Zurich American Insurance Company  
 INSURED: Niagara Falls Water Board & Niagara Falls Public Niagara Falls NY 14304  
 POLICY YEAR EFFECTIVE: 10/18/2023

TYPE ***	AUTO #	YEAR	MAKE	MODEL	COST NEW	COMP DED	COLL DED	VIN	VALUATION
E	17	2016	FORD	F65 DUMP	\$0	No Coverage	No Coverage	1FDNF6AY9GDA00167	Actual Cash Value
E	18	2020	PETERBILT	TANDEM DUMP	\$0	No Coverage	No Coverage	2NP3LJ0X9LM682058	Actual Cash Value
E	19	1997	GODWIN	CD150M	\$0	No Coverage	No Coverage	16MJ10612VD021569	Actual Cash Value
E	20	1997	GODWIN	CD150M	\$0	No Coverage	No Coverage	16MJ10615VD021565	Actual Cash Value
E	21	2017	FREIGHTLINER	VACUUM PRESSURE	\$0	No Coverage	No Coverage	1FVHG5FE1JHJP7422	Actual Cash Value
E	22	2020	CHEVROLET	EQUINOX	\$0	No Coverage	No Coverage	3GNAX5EV8L8639460	Actual Cash Value
E	23	2020	CHEVROLET	EQUINOX	\$0	No Coverage	No Coverage	3GNAX5EV8L8639461	Actual Cash Value
E	24	2020	CHEVROLET	EQUINOX	\$0	No Coverage	No Coverage	3GNAX5EV8L8639462	Actual Cash Value
E	25	2021	CHEVROLET	TAHOE	\$0	No Coverage	No Coverage	1GNSKNKT3MR407889	Actual Cash Value
E	26	2021	CHEVY	SILVERADO	\$0	No Coverage	No Coverage	1GCRYAEHXMZ367879	Actual Cash Value
E	27	2021	CHEVY	SILVERADO	\$0	No Coverage	No Coverage	1GCRYAEH5MZ366803	Actual Cash Value
E	28	2021	CHEVY	SILVERADO	\$0	No Coverage	No Coverage	1GCRYAEH3MZ367089	Actual Cash Value
E	29	2021	CHEVY	SILVERADO	\$0	No Coverage	No Coverage	1GCRYAEH4MZ368221	Actual Cash Value
E	30	2021	CHEVY	SILVERADO	\$0	No Coverage	No Coverage	1GCRYAEH9MZ367999	Actual Cash Value
E	31	2021	CHEVY	SILVERADO	\$0	No Coverage	No Coverage	1GCRYAEH5MZ366980	Actual Cash Value
E	32	2021	CHEVY	SILVERADO	\$0	No Coverage	No Coverage	1GCRYAEH9MZ367484	Actual Cash Value
E	33	2021	CHEVY	SILVERADO	\$0	No Coverage	No Coverage	1GCRYAEH3MZ368033	Actual Cash Value

\*\*\*Type Codes E-Existing, N-New, M-Modified, D-Deleted, PD-Previously Deleted



ALLIED PUBLIC RISK –AUTO SCHEDULE  
 Zurich American Insurance Company  
 INSURED: Niagara Falls Water Board & Niagara Falls Public Niagara Falls NY 14304  
 POLICY YEAR EFFECTIVE: 10/18/2023

TYPE ***	AUTO #	YEAR	MAKE	MODEL	COST NEW	COMP DED	COLL DED	VIN	VALUATION
E	34	2021	CHEVY	SILVERADO	\$0	No Coverage	No Coverage	1GCRYAEH1MZ368225	Actual Cash Value
E	35	2021	JOHN DEERE	333G Compact Track Loader	\$0	No Coverage	No Coverage	1T0333GMKNF416440	Actual Cash Value
E	36	2021	JOHN DEERE	444 FRONT LOADER	\$0	No Coverage	No Coverage	1DW444PATMLZ12647	Actual Cash Value
E	37	2023	FREIGHTLINER	VAC-CON	\$0	No Coverage	No Coverage	1FVHG3FE7PHNN3747	Actual Cash Value
E	38	2022	JOHN DEERE	331G Compact track Loader	\$0	No Coverage	No Coverage	1T0331GMHNF430318	Actual Cash Value
E	39	2021	JOHN DEERE	75G Exc W/Aux Hyd	\$0	No Coverage	No Coverage	1FF075GXCMJ017792	Actual Cash Value
E	40	2021	JOHN DEERE	75G Exc W/Aux Hyd	\$0	No Coverage	No Coverage	1FF075GXCMJ017789	Actual Cash Value
E	41	2022	FORD	F150 PICKUP	\$0	No Coverage	No Coverage	1FTVW1EL1NWX05534	Actual Cash Value
E	42	2008	CHEVY	STEP VAN	\$0	No Coverage	No Coverage	5B4KPD28083434241	Actual Cash Value
E	43	2023	FORMULA	UTILITY TRAILER	\$0	No Coverage	No Coverage	53BFTEA28PB014775	Actual Cash Value
E	44	2022	DISCOVERY	CARGO TRAILER	\$0	No Coverage	No Coverage	7G1BE1427NE014165	Actual Cash Value

\*\*\*Type Codes E-Existing, N-New, M-Modified, D-Deleted, PD-Previously Deleted



*NIAGARA FALLS WATER BOARD RESOLUTION # 2023-09-007*

**ACCEPTING PROPOSAL FOR 2023 AUDIT SERVICES**

**WHEREAS**, the Niagara Falls Water Board issued a request for proposals for annual audit services for its 2023 fiscal year with the option at its sole discretion to utilize the auditor's services for the 2024 and/or 2025 years and after 2025 providing the option for the Water Board and selected auditor mutually to agree to extend the engagement for additional one-year terms; and

**WHEREAS**, three proposals were received by the deadline set forth in the request for proposals, which have been reviewed and evaluated pursuant to the criteria set forth in the Request for Proposals; and

**WHEREAS**, Water Board staff recommend that the Water Board accept the proposal by EFPR Group, CPAs PLLC, dated September 8, 2023, with a proposed fee for the audit services required for the year ending December 31, 2023 of \$24,000;

\* CONTINUED ON NEXT PAGE \*

**NOW THEREFORE BE IT**

**RESOLVED**, that on behalf of the Niagara Falls Water Board, the Executive Director hereby is authorized to accept the September 8, 2023 proposal by EFPR Group, CPAs PLLC, dated September 8, 2023, with a proposed fee for the audit services required for the year ending December 31, 2023 of \$24,000.

*Water Board Personnel Responsible for Implementation of this Resolution:*

Executive Director  
Director of Financial Services

*Water Board Budget Line or Capital Plan Item with Funds for this Resolution:*

Budget Line: FGB.8000.0000.0459.000 - Auditors  
Budget Line Provided by: B. Majchrowicz

On September 25, 2023, the question of the adoption of the foregoing Resolution was duly put to a vote on roll call, which resulted as follows:

	<b>Yes</b>	<b>No</b>	<b>Abstain</b>	<b>Absent</b>
Board Member Asklar	[ ]	[ ]	[ ]	[ ]
Board Member Kimble	[ ]	[ ]	[ ]	[ ]
Board Member Larkin	[ ]	[ ]	[ ]	[ ]
Board Member Leffler	[ ]	[ ]	[ ]	[ ]
Chairman Forster	[ ]	[ ]	[ ]	[ ]

Signed By:

Vote Witnessed By:

\_\_\_\_\_  
Nicholas J. Forster, Chairman

\_\_\_\_\_  
Sean W. Costello, Secretary to Board

September 8, 2023

Mr. Brian Majchrowicz  
Director of Financial Services  
Niagara Falls Water Board  
5815 Buffalo Avenue  
Niagara Falls, New York 14304

Dear Mr. Majchrowicz:

Attached is our proposal to provide audit and related services to Niagara Falls Water Board for the years ending December 31, 2023, 2024 and 2025.

Please call me if you have any questions with regard to this proposal.

Very truly yours,

EFPR GROUP, CPAs, PLLC

  
Douglas E. Zimmerman, CPA  
Partner

DFZ:kms

Enclosures

**NIAGARA FALLS WATER BOARD**  
**Proposal to Provide**  
**Audit and Related Services**  
**Years ending December 31, 2023, 2024 and 2025**



**EFPR Group, CPAs, PLLC**  
**Douglas E. Zimmerman, CPA**  
**Partner**  
**[dzimmerman@efprgroup.com](mailto:dzimmerman@efprgroup.com)**

**September 8, 2023**

September 8, 2023

Mr. Brian Majchrowicz  
Director of Financial Services  
Niagara Falls Water Board  
5815 Buffalo Avenue  
Niagara Falls, New York 14304

Dear Mr. Majchrowicz:

We are pleased to present our proposal to provide audit and related services to the Niagara Falls Water Board (the Board) for the years ending December 31, 2023, 2024 and 2025. Our proposal is a firm offer for a period of 90 days from the deadline for proposal submission. We believe the EFPR Group, CPAs, PLLC is highly qualified to provide professional audit services to the Board based on the following:

- Our previous experience providing audit and related services to the Board.
- Our experience with regard to providing audit and related services for over 175 governmental organizations annually.
- Our firm's ability to bring a wealth of New York State Public Authority audit experience having audited some of the largest public authorities in New York State, including Empire State Development, New York Convention Center Operating Corporation, New York State Bridge Authority, New York State Olympic Regional Development Authority and Lower Manhattan Development Corporation.
- Our experience with regard to providing audit and related services for organizations required to have audits which are performed in accordance with Government Auditing Standards. We audit over 350 organizations annually in accordance with Government Auditing Standards.
- Our experience with regard to providing audit and related services for organizations which require audits performed in accordance with the provisions of Office of Management and Budget (OMB) Uniform Administrative Requirements, Cost Principles and Audit Requirements for Federal Awards. We provide annual audit services for over 250 single audit compliant organizations.
- Our experience providing audit and related services to the following:
  - Niagara Falls Water Board
  - Monroe County Water Authority
  - Town of Hempstead Sanitary District Number Two
  - Town of Hempstead Sanitary District Number Seven
  - Binghamton-Johnson City Joint Sewage Board

Mr. Brian Majchrowicz  
September 8, 2023

- Our experience in providing annual financial statement audit and related services to Public Authorities and Public Benefit Corporations, including the following:
  - Broome County Land Bank Corporation
  - Cheektowaga Economic Development Corporation
  - Chemung County Property Development Corporation
  - County of Orleans Industrial Development Agency
  - Dunkirk Industrial Development Agency
  - Dunkirk Local Development Corporation
  - Dutchess County-Poughkeepsie Land Bank
  - Emerald Corporate Center Economic Development Corporation
  - Fulton Community Development Agency
  - Harlem Community Development Corporation
  - Hudson River Park Trust
  - Incorporated Village of Hempstead Community Development Agency
  - Islip Resource Recovery Agency
  - Kingston City Land Bank
  - Kingston Local Development Corporation
  - Lake Champlain-Lake George Regional Planning Board
  - Land Reutilization Corporation of the Capital Region
  - Lower Manhattan Development Corporation
  - Lumber City Development Corporation
  - Monroe County Water Authority
  - New York State Urban Development Corporation d/b/a Empire State Development
  - New York Convention Center Development Corporation
  - New York Convention Center Operating Corporation (Jacob K. Javits Convention Center)
  - New York Job Development Authority
  - New York State Bridge Authority
  - New York State Homeless Housing and Assistance Corporation
  - New York State Olympic Regional Development Authority
  - Newburg Community Land Bank
  - N.F.C. Development Corporation
  - Niagara Falls Urban Renewal Agency
  - Niagara-Orleans Regional Land Improvement Corporation
  - Ogdensburg Bridge and Port Authority
  - Orleans County Local Development Corporation
  - Roosevelt Island Operating Corporation
  - Steuben County Industrial Development Agency
  - Sullivan Broadband Local Development Corporation
  - Town of Erwin Industrial Development Agency
  - Town of Hempstead Community Development Agency
  - Town of Plattsburgh Local Development Corporation
  - Trust for Cultural Resources of the City of New York
  - Warren County Local Development Corporation
  - Washington County Local Development Corporation
  - Wayne County Industrial Development Agency
- Our ability to provide quality services on a timely basis for reasonable fees



Mr. Brian Majchrowicz  
September 8, 2023

Our depth of experience working with many public benefit corporations and governmental entities across New York State should provide peace of mind that the Board would be served by a highly competent team of professionals committed to assist in whatever capacity you require. We understand that for our services to be valuable to the Board, we need to provide more than just financial reporting. At the EFPR Group, CPAs, PLLC, we take a proactive approach to our client relationships in order to ensure we are anticipating our client's needs before they call on us for assistance. We are available throughout the year to answer questions and address concerns that may arise.

We would consider it a distinct privilege to provide professional services as outlined in this letter or any additional services you desire. Simply put, we want to be your auditors and business consultants. Please contact us if there are any questions regarding this proposal.

Very truly yours,

EFPR GROUP, CPAs, PLLC

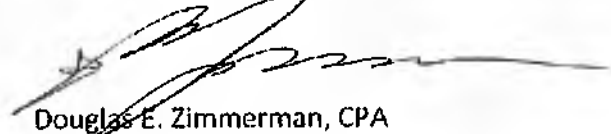
A handwritten signature in black ink, appearing to read 'Douglas E. Zimmerman', is written over a horizontal line.

Douglas E. Zimmerman, CPA  
Partner

## **FIRM PHILOSOPHY**

The EFPR Group, CPAs, PLLC was founded on the principle of providing our clients with the same high quality level of service expected from a national firm yet with the dedicated involvement that can only be developed by personal attention. The primary mission of our Firm has always been helping our clients succeed. We are committed to delivering services targeted to each client's critical needs and industry niche.

## **KEY CONSIDERATIONS REGARDING THE EFPR GROUP**

Our Firm has achieved its present position in the accounting profession by providing quality services on a timely basis, for reasonable fees. Accounting firms should be evaluated in light of several important conditions:

- The firm's qualifications, experience and its ability to provide auditing, accounting and consulting services for a reasonable fee.
- The firm's ability to assemble and commit a team of professionals experienced in providing audit, accounting and consulting services for governmental organizations, specifically public benefit corporations.
- The firm's involvement of client personnel and active participation and coordination on a year-round basis.
- The firm's commitment to provide services which will contribute to the success of our clients.

In the following paragraphs, we shall demonstrate that the EFPR Group, CPAs, PLLC is the accounting firm best qualified to serve the Niagara Falls Water Board.

## **FRESH PERSPECTIVE**

Changing auditors does not have to be difficult. The professionals at the EFPR Group, CPAs, PLLC are excited about providing the Board with a fresh perspective on internal controls, compliance risks, and other operational matters. As noted throughout our proposal, our objective is to provide value beyond our financial and compliance audits.

## **LICENSED TO PRACTICE IN NEW YORK STATE**

The EFPR Group, CPAs, PLLC is licensed to practice in New York State. Please see Appendix A for evidence of the firm's license to practice and licenses of key individuals to be assigned to the engagement.

## **INDEPENDENCE**

The EFPR Group, CPAs, PLLC is independent of the Niagara Falls Water Board as defined by generally accepted auditing standards and U.S. Government Accountability Office (GAO)'s Government Auditing Standards. Accordingly, no relationship exists between the EFPR Group, CPAs, PLLC and the Board or any of its employees, Board members or with any person or agency that constitutes a conflict of interest with respect to the Board.

## **FIRM QUALIFICATIONS AND EXPERIENCE**

The EFPR Group, CPAs, PLLC has been providing audit and related services to governmental organizations for over 50 years. We trace our Buffalo roots back to the early 1980s through our predecessor firm of Toski & Co., CPAs, P.C. The other firms that merged to become the EFPR Group, CPAs, PLLC (Eldredge Fox & Porretti, LLP, Rotenberg & Co., LLP, and S. Barrie Godown, CPA, P.A.) trace their roots back to the 1960s and 1970s.

The EFPR Group, CPAs, PLLC provides audit, accounting and consulting services to over 175 governmental organizations on an annual basis. We serve more than 350 organizations which require an audit performed in accordance with Government Auditing Standards and over 250 clients that require audits performed in accordance with the provisions of Office of Management and Budget (OMB) Uniform Administration Requirements, Cost Principles and Audit Requirements for Federal Awards. Our Firm employs 200 professionals with 41 partners and directors. The Firm's Government Audit Practice Group consists of 40 highly trained professionals who provide audit and related services to governmental organizations on a year round basis.

Our Firm has offices located in Williamsville, Rochester, and Corning, New York. The fieldwork associated with the engagement will be performed at the Board's office located in Niagara Falls, New York by the professionals from the Firm's Government Audit Practice Group. Please see Appendix A for detailed resumes of the Firm's key Government Audit Practice Group members and Appendix B for a partial listing of governmental organizations which are our clients.

Our Firm has substantial experience providing audit, accounting and consulting services to various governmental organizations. We are very familiar with generally accepted Government Auditing Standards (GAGAS), issued by the Comptroller General of the United States. We perform approximately 350 GAGAS audits annually. Our team of professionals from our Government Audit Practice Group is well versed and keeps up-to-date on all standards affecting the government environment.

**Public Authority Experience** - Our Firm has substantial experience in providing annual financial statement audit and related services to Public Authorities. These organizations are different from other governmental organizations; therefore, our previous experience with these organizations is a benefit for your organization.

**Monroe County Water Authority** - We perform the annual audit of the financial statements of the Authority in accordance with auditing standards generally accepted in the United States of America and the provisions of Government Auditing Standards, issued by the Comptroller General of the United States. The Authority was created to finance, construct, operate and maintain a water supply and distribution system for the benefit of the residents of the County and State of New York.

**New York State Urban Development Corporation d/b/a Empire State Development** - We perform the annual audit of the general purpose financial statements of the Corporation (a component unit of the State of New York) in accordance with auditing standards generally accepted in the United States of America, the provisions of Government Auditing Standards, issued by the Comptroller General of the United States, and Office of Management and Budget (OMB) Uniform Administrative Requirements, Cost Principles and Audit Requirements for Federal Awards. The Corporation's goal is to create and retain jobs and to reinvigorate economically distressed areas of the State. The Corporation administers various economic development programs which provides tax incentives designed to attract new businesses to New York State and to enable existing businesses to expand and create more jobs. The Corporation has over 150 subsidiaries which are consolidated for financial reporting purposes. Our firm provides audit and related services to various subsidiaries of Empire State Development. Empire State Development has annual revenues in excess of \$2.3 billion and assets of more than \$26 billion.

**New York State Olympic Regional Development Authority** - We perform the annual audit of the financial statements of the Authority in accordance with auditing standards generally accepted in the United States of America and the provisions of Government Auditing Standards, issued by the Comptroller General of the United States. In connection with this engagement we also prepare an Independent Auditors' Report on Compliance with Investment Guidelines. The Authority is currently involved in a major construction project to improve its facilities across all of the venues. The projects include a Mountain Coaster, Zip-Line, three new chairlifts, pumphouse improvements, the Mountain Pass Lodge at Mt. Van Hoevenberg, the Legacy Lodge at Whiteface Mountain and the beginning of revitalization of the Olympic Center.

**Binghamton-Johnson City Joint Sewage Board** - We perform the annual audit of the financial statements of the Board in accordance with auditing standards generally accepted in the United States of America, the provisions of Government Auditing Standards, issued by the Comptroller General of the United States, and Office of Management and Budget (OMB) Uniform Administrative Requirements, Cost Principles and Audit Requirements for Federal Awards. The Board was established by the municipal cooperation agreement between the City of Binghamton and the Village of Johnson City for the operation of a joint wastewater treatment facility.

**Town of Hempstead Sanitary Districts** - We perform the annual audits of the financial statements of District Number Two and District Number Seven in accordance with auditing standards generally accepted in the United States of America and the provisions of Government Auditing Standards, issued by the Comptroller General of the United States. The Districts provide for the collection, removal and disposal of all waste, special waste and recyclables within its territorial jurisdiction within the Town of Hempstead, New York.

**New York Convention Center Operating Corporation** - We perform the annual audit of the financial statements of the Corporation in accordance with auditing standards generally accepted in the United States of America and the provisions of Government Auditing Standards, issued by the Comptroller General of the United States. The Corporation was established to operate the Jacob K. Javits Convention Center of New York.

**Ogdensburg Bridge and Port Authority** - We perform the annual audit of the financial statements of the Authority in accordance with auditing standards generally accepted in the United States of America and the provisions of Government Auditing Standards, issued by the Comptroller General of the United States. In connection with this engagement we audit the operations of the Ogdensburg International Airport.

**Lower Manhattan Development Corporation** - We perform the annual financial statement of the Corporation in accordance with auditing standards generally accepted in the United States of America, the provisions of Government Auditing Standards, issued by the Comptroller General of the United States, and Office of Management and Budget (OMB) Uniform Administrative Requirements, Cost Principles and Audit Requirements for Federal Awards.

**Hudson River Park Trust** - We perform the annual financial statement of the Trust in accordance with auditing standards generally accepted in the United States of America, the provisions of Government Auditing Standards, issued by the Comptroller General of the United States, and Office of Management and Budget (OMB) Uniform Administrative Requirements, Cost Principles and Audit Requirements for Federal Awards. Hudson River Park Trust is a public benefit corporation created to oversee the planning, construction and operation of the Hudson River Park which is located from Battery Place to 59<sup>th</sup> Street in New York City. The Trust is responsible for the \$262 million of State and City funds which have been allocated to reconstruct the piers and related infrastructure improvements in the Park.

**Public Authority Experience** - Our Firm has experience in providing annual financial statement audit and related services to Public Authorities. These organizations are different from other governmental organizations; therefore, our previous experience with these organizations is a benefit for your organization. We have experience providing services to the following:

- Broome County Land Bank Corporation
- Cheektowaga Economic Development Corporation
- Chemung County Property Development Corporation
- County of Orleans Industrial Development Agency
- Dunkirk Industrial Development Agency
- Dunkirk Local Development Corporation
- Dutchess County-Poughkeepsie Land Bank
- Emerald Corporate Center Economic Development Corporation

- Fulton Community Development Agency
- Harlem Community Development Corporation
- Hudson River Park Trust
- Incorporated Village of Hempstead Community Development Agency
- Islip Resource Recovery Agency
- Kingston City Land Bank
- Kingston Local Development Corporation
- Lake Champlain-Lake George Regional Planning Board
- Land Reutilization Corporation of the Capital Region
- Lower Manhattan Development Corporation
- Lumber City Development Corporation
- Monroe County Water Authority
- New York State Urban Development Corporation d/b/a Empire State Development
- New York Convention Center Development Corporation
- New York Convention Center Operating Corporation (Jacob K. Javits Convention Center)
- New York Job Development Authority
- New York State Bridge Authority
- New York State Homeless Housing and Assistance Corporation
- New York State Olympic Regional Development Authority
- Newburg Community Land Bank
- N.F.C. Development Corporation
- Niagara Falls Urban Renewal Agency
- Niagara-Orleans Regional Land Improvement Corporation
- Ogdensburg Bridge and Port Authority
- Orleans County Local Development Corporation
- Roosevelt Island Operating Corporation
- Steuben County Industrial Development Agency
- Sullivan Broadband Local Development Corporation
- Town of Erwin Industrial Development Agency
- Town of Hempstead Community Development Agency
- Town of Plattsburgh Local Development Corporation
- Trust for Cultural Resources of the City of New York
- Warren County Local Development Corporation
- Washington County Local Development Corporation
- Wayne County Industrial Development Agency

#### **Additional Services Provided to Governmental Clients**

Our Firm has assisted our governmental clients in obtaining a Certificate of Achievement for Excellence in Financial Reporting from the Government Finance Officers Association. We are committed to providing the highest quality services and assisting governmental entities in meeting regulatory deadlines.

We have provided consulting services to our clients with regard to implementation of Governmental Accounting Standards Board (GASB) Statement No. 33 - "Accounting and Financial Reporting for Nonexchange Transactions," and GASB Statement No. 34 - "Basic Financial Statements and Management's Discussion and Analysis." We have worked extensively with our government clients in ensuring that they have complied with the reporting requirements of GASB Statement No. 34. Consulting services offered to our clients with regard to implementation of GASB Standards include, but are not limited to, the following:

- Implementation of infrastructure reporting
- Implementation of fixed asset policies and procedures
- Reporting of infrastructure costs and assistance and guidance in preparing the Management Discussion and Analysis (MD&A)

Additionally, we keep our clients abreast of changes in the governmental accounting environment. We have assisted our clients with the implementation of the requirements of GASB Statements No. 75 - "Accounting and Financial Reporting for Postemployment Benefits Other Than Pensions." The primary objective of this Statement is to improve accounting and financial reporting by state and local governments for postemployment benefits other than pensions (other postemployment benefits or OPEB).

GASB Statement No. 84 - "Fiduciary Activities" establishes criteria for identifying fiduciary activities of all state and local governments that generally focuses on (1) whether a government is controlling the assets of the fiduciary activity and (2) the beneficiaries of the fiduciary relationship. Activities meeting the criteria should be reported in a fiduciary fund in the basic financial statements, and should present a statement of fiduciary net position and a statement of changes in fiduciary net position.

We have also recently been assisting our clients with the implementation of the requirements of GASB Statement No. 87 - "Leases." This statement establishes a single model for lease accounting based on the foundational principle that leases are financings of the right to use an underlying asset. This statement requires recognition of certain lease assets and liabilities that previously were classified as operating leases and recognizes inflows and outflows of resources based on the payment provisions of the contract.

## Quality Assurance

### Peer Review

The EFPR Group, CPAs, PLLC retains an independent accounting firm to conduct a review of its system of quality control every three years in accordance with the rigorous standards of the American Institute of Certified Public Accountants. In May 2023, our Firm successfully completed the most recent peer review of its accounting and auditing practice. The review determined that the Firm complies with the stringent quality control standards set by the American Institute of Certified Public Accountants. Our Firm has received the highest rating possible (pass) with no letter of comments being required in each of its last 11 peer reviews. According to the peer review team, less than one percent of the firms in the nation achieve this level of excellence. We believe that this attests to our commitment to quality. Peer reviews, which are performed every three years, are required of all CPA firms and are conducted in accordance with rules issued by the American Institute of Certified Public Accountants. (See Appendix C for a copy of the report issued in connection with our most recent peer review.)

### CPAmerica, Inc.

EFPR Group, CPAs, PLLC is an independently owned and operated member firm of CPAmerica, Inc., one of the largest associations of CPA firms in the United States. Through our affiliation, we have instant access to the expertise and resources of more than 4,000 professionals and more than 700 partners. CPAmerica is a member of Crowe Global, providing our firm access to the eighth largest accounting network in the world, with over 200 independent accounting and advisory firms in 130 countries. By supplementing our services, CPAmerica allows us to:

- Enhance our client services and broaden our capabilities overall
- Expand our domestic and international coverage
- Gain greater technical knowledge in specialty areas
- Utilize professionals with experience in a wide range of industries
- Access the most up-to-date technical information
- Participate in the latest training programs
- Utilize state-of-the-art, customized computer systems
- Provide our clients with key contacts and sophisticated professionals throughout the U.S.

CPAmerica brings us the necessary tools to help us better serve our clients with greater flexibility, efficiency and cost effectiveness.

### **Government Audit Quality Center**

We are also a member of the American Institute of Certified Public Accountants Government Audit Quality Center (GAQC). The GAQC promotes the importance of quality governmental audits and the value of such audits to purchasers of governmental audit services. As members, we have access to the latest developments in accounting, auditing, and the various rules and regulations that affect governmental audits. We also receive periodic updates on current issues through news alerts and Webcasts. We are proud of the quality of our work and in order to ensure that this high level of quality is maintained, we have established a comprehensive quality assurance program. The program starts with hiring the best people available and continues with extensive continuing education, an annual minimum of 40 hours per staff member. Our involvement in the GAQC is optional, but indicates a level of commitment above non-member Certified Public Accounting firms. Our participation requires that our firm and personnel attain additional continuing professional education on an annual basis.

### **STAFF QUALIFICATIONS AND EXPERIENCE**

Achieving our present position in the profession has come as a result of being responsive to the needs of our clients. A combination of a coordinated team approach and up-to-date knowledge allows for the most efficient approach to providing comprehensive professional services. Accordingly, we will assemble an engagement team that will include audit personnel with extensive public benefit corporation and governmental audit experience. Please see Appendix A for detailed resumes of the Firm's key Government Audit Practice Group members. The key individuals available to be assigned to this engagement and their roles are as follows:

Douglas E. Zimmerman, CPA will serve as the engagement quality control review partner. Doug will provide a secondary review of all deliverables and critical engagement decisions and will be available throughout the engagement to consult and review on any auditing and accounting questions that may arise. He has over 36 years of public accounting experience and currently functions as a partner in the Firm. He has extensive experience in providing audit, accounting and consulting services for numerous public benefit corporations and governmental organizations. Doug is licensed in New York, Florida and Massachusetts as a Certified Public Accountant.

John S. Costilow, CPA will serve as the engagement partner in charge of our relationship with Niagara Falls Water Board. John will oversee all services provided and ensure that they are delivered in a timely and efficient manner. He will be responsible for all matters concerning accounting policy, participate in the planning phases of our engagement, review all working papers and reports prepared, and attend meetings with management and the Board. He has over 16 years of public accounting experience. He currently functions as a partner in the Firm and has extensive experience in providing audit, accounting and consulting services for numerous public benefit corporations and governmental organizations. John is licensed in New York State as a Certified Public Accountant.

Justin Pepe will serve as senior accountant on this engagement. Justin has over two years of public accounting experience. He currently functions as a senior accountant in the Firm and has extensive experience in providing audit, accounting and consulting services for numerous public benefit corporations and governmental organizations.

Staff Accountant: Your account will also be assigned an additional staff accountant from the Firm's Government Audit Practice Group who will work as part of the engagement team in performing your audit.

### **Continuing Professional Education**

With regard to continuing professional education (CPE), each of our staff members is required to complete an annual minimum of 40 hours of CPE programs approved by the American Institute of Certified Public Accountants. Additionally, since we perform audits in accordance with generally accepted Government Auditing Standards (GAGAS) (over 350 each year), our staff members must complete at least 24 of the 80 hours (over a two-year period) of CPE in subjects directly related to the government environment and government auditing. Due to the substantial volume of governmental audits performed, our Firm continually monitors staff CPE compliance with the GAGAS requirements. All of the individuals listed above are in compliance with the CPE requirements.

### **MWBE/SDVOBE Participation**

Our Firm would like to express its willingness to engage subcontractors which are Certified Minority and Women-Owned and Service-Disabled Veteran-Owned accounting firms, if requested by the Board.

The EFPR Group, CPAs, PLLC is an equal opportunity employer and as such possesses a firm commitment to affirmative action and to hiring and working with only the best qualified candidates and subcontracting firms regardless of gender or ethnic origin. Our Firm does not discriminate against any employee or applicant or subcontractor firm. When selecting a subcontractor firm to work with, EFPR Group, CPAs, PLLC looks at the Firm's reputation in the marketplace, and past performance with their clients. We also review whether the firm possesses the required expertise and experience, as well as whether the firm is sufficiently staffed with qualified individuals who will be able to work with our audit staff as part of our engagement team.

### **Minority-Owned Business Enterprise**

Valles Vendiola LLP, a certified Minority and Women Owned Business Enterprise, has expressed a willingness to serve as a subcontractor on this engagement, if requested by the Board. The firm was originally organized in 1983 and has specialized in government audits or audits of government contracts, including government contract auditing services. The firm has provided government auditing services, government audits or audits of government contracts to the New York City Department of Health and Mental Hygiene, New York City Administration for Children's Services, New York City Department of Youth and Community Development, Roosevelt Island Operating Corporation, New York Horse Breeding Corporation, New York City Health and Hospitals Corporation, New York State Department of Transportation, and New York City Economic Development Corporation.

We have utilized the services of Valles Vendiola LLP as a member of our audit engagement team on our engagements for the New York State Office of the State Comptroller, New York State Division of the Budget, New York State Office for People With Developmental Disabilities, New York State Executive Chamber, New York State Office for People With Developmental Disabilities, Lower Manhattan Development Corporation, SUNY at Stony Brook Dental School, New York State Department of Transportation, City University of New York and a number of other governmental organizations. The professionals from Valles Vendiola LLP work jointly with our professional staff, presenting a seamless engagement team to our clients, resulting in improved client services.



Women-Owned Business Enterprise

Kristie M. Beach, CPAs, PLLC, a certified Women Owned Business Enterprise, headquartered in Rochester, New York, has expressed a willingness to serve as a subcontractor on this engagement, if requested by the Board. The firm has experience in auditing, accounting and consulting services for numerous governmental and nonprofit organizations.

We have utilized the services of Kristie M. Beach, CPAs, PLLC as a member of our audit engagement team on our engagements for the City University of New York, New York State Office for People With Developmental Disabilities, Empire State Development, Hudson River Park Trust and a number of other governmental organizations. The professionals from Kristie M. Beach, CPAs, PLLC work jointly with our professional staff, presenting a seamless engagement team to our clients, resulting in improved client services.

Service-Disabled Veteran-Owned Business Enterprise

RJ Williams Group, CPAs, PLLC, a certified Service-Disabled Veteran-Owned Business Enterprise, has expressed a willingness to serve as a subcontractor on this engagement, if requested by the Board. The firm is a full service accounting, tax and advisory firm headquartered in Rochester, New York.

The senior and staff accountants from our subcontractors will work under the direct supervision of Douglas E. Zimmerman and John S. Costilow, the partners assigned to the engagement, to ensure the quality of the work performed is in accordance with applicable professional standards. The senior and staff accountants from our subcontractors will work as an integrated part of our engagement team to provide the requested audit services for the Board. All work performed by our subcontractors is reviewed and approved by EFPR Group. Accordingly, we take complete responsibility for the services performed by our subcontractors.

**REFERENCES**

Our Firm has provided various audit services to numerous public benefit corporations and governmental organizations. The following individuals may be contacted to provide references with regard to the quality of our Firm’s work:

City of Niagara Falls

Scope of work: Audit of financial statements, including compliance with Government Auditing Standards and single audit. Also, audit the City’s compliance applicable to the major state transportation assistance program.

Date: 2021 and ongoing  
Contact: Mr. Daniel Morello  
City Controller  
745 Main Street  
Niagara Falls, New York 14302  
(716) 286-4371  
[daniel.morello@niagarafallsny.gov](mailto:daniel.morello@niagarafallsny.gov)

Monroe County Water Authority

Scope of work: Audit of financial statements, including compliance with Government Auditing Standards.

Date: 2020 and ongoing  
Contact: Ms. Amy A. Molinari, CPA  
Director of Finance & Business Services  
475 Norris Drive  
Rochester, New York 14610  
(585) 442-2001 ext 240  
[amy.molinari@mcwa.com](mailto:amy.molinari@mcwa.com)

New York State Olympic Regional Development Authority

Scope of work: Audit of financial statements, including compliance with Government Auditing Standards and single audit.

Date: 2021 and ongoing

Contact: Ms. Peggy Evatt  
Director of Finance  
2634 Main Street  
Lake Placid, New York 12946  
(518) 302-5317  
[pevatt@orda.org](mailto:pevatt@orda.org)

Ogdensburg Bridge and Port Authority

Scope of work: Audit of financial statements, including compliance with Government Auditing Standards.

Date: 2006 and ongoing

Contact: Mr. Steve Lawrence  
Executive Director  
One Bridge Plaza, Suite 102  
Ogdensburg, New York 13669  
(315) 393-4080  
[slawrence@ogdensport.com](mailto:slawrence@ogdensport.com)

Binghamton-Johnson City Joint Sewage Board

Scope of work: Audit of financial statements, including compliance with Government Auditing Standards and single audit.

Date: 2018 and ongoing

Contact: Mr. Chuck Shager  
Chief Financial Officer  
38 Hawley Street  
Binghamton, New York 13901  
(607) 772-7011  
[ceshager@cityofbinghamton.com](mailto:ceshager@cityofbinghamton.com)

**AUDIT APPROACH**

Our audits are made in accordance with auditing standards generally accepted in the United States of America and, accordingly, include such tests of the accounting records and other auditing procedures as we consider necessary and appropriate in order to express an opinion on the financial statements.

Although audits conducted by different firms should all comply with certain professional requirements and thus might appear identical in nature, you should distinguish individual firms by at least two key factors:

1. The extent to which the firm understands or expands its understanding of your organization in advance of the audit and tailors its auditing procedures to the conditions and needs of the Board.
2. The pertinent skills and processes the auditor can bring to bear upon the engagement to ensure an effective and efficient audit.

## Transition from Current Auditor

Changing auditors for the Board should not be a difficult task. Fortunately, your proposed engagement team has had many opportunities over the years to step in as the new auditor. This experience helps ensure that the transition goes as smoothly as possible. From communicating with the predecessor auditor, reviewing their work papers, documenting and understanding your business processes, we will focus on minimizing the challenges that sometimes come with an auditor change. We will obtain as much information as possible from your predecessor auditor and then assemble a list of any items needed from the Board's management, along with mutually agreed-upon response dates. Our objective as your professional service provider will be to front load as much work as possible, including our transition as your external auditor. Because of your engagement team's experience with public benefit corporations and other governmental organizations, our engagement team will hit the ground running, resulting in minimal disruption to your day-to-day operations.

## Financial Statement Audit

Audit examinations performed by our Firm are conducted from a risk-based approach. This approach yields two major benefits:

- Maximization of understanding of the Board's operating environment, and
- Minimization of audit time by starting with broad considerations and narrowing to specific audit objectives in critical areas.

The audit of the financial statements of the Niagara Falls Water Board will consist of the following four phases:

- Planning
  - Systems evaluation
  - Testing
  - Reporting
- Planning is the first step in the audit engagement and provides the foundation for the direction of the audit. This phase of the audit involves meeting with the Audit Committee and management of the Board to clearly identify the lines of communication, perform the risk analysis, discuss the audit scope and concerns and set expectations. While facilitating an understanding between our firm and the Board, we highlight areas, which will receive emphasis during our audit. This type of analytical review process permits identification of critical areas. As a result, appropriate audit procedures are focused therein.
  - Systems Evaluation consists of the following steps:
    - A review of internal control systems of the Board;
    - A review of the information technology systems utilized by the Board to prepare its accounting records and monitor compliance with regulatory requirements;
    - An identification of control strengths and weaknesses in management and accounting controls; and
    - The development of a tailored audit program to be responsive to the Board's concerns and reflective of the internal control system.
  - Testing is the largest part of the audit process and includes both compliance test of internal controls and regulatory requirements and substantive test of the Board's financial data.

The EFPR Group, CPAs, PLLC uses sampling in selecting items for examination by compliance and/or substantive tests where it is determined to be cost beneficial to sample the population. Our Firm has an Audit and Accounting Manual which contains procedures for the control and evaluation of sampling risk, selection of samples, and evaluation of sample results.

Audit sampling will normally be used to perform the following tests:

- Substantive tests as part of the audit of the Board's basic financial statements;
  - Compliance tests to provide reasonable assurance that internal control (accounting and administrative) procedures used in administering federal and state financial assistance programs are being applied as prescribed; and
  - Substantive tests of compliance with laws and regulations as part of the audit of the basic financial statements and for the purpose of reporting on compliance with laws and regulations as they relate to the schedule of federal financial assistance.
- Reporting is completed at the conclusion of the audit process. This phase will include the preparation of the draft financial statements and management letter. Management of the Board will be provided drafts of all reports. These drafts will be reviewed in detail and any questions or concerns of management will be appropriately addressed. Reports will only be finalized after approval of management and the Audit Committee of the Board.

Our management letter will discuss internal control recommendations and suggestions for procedural improvements we identified as part of the audit. The letter will also include observations about accounting methods and procedures, business and industry practices or issues, operational ideas, and suggestions to further enhance the Board's operations. We will advise you of any new accounting pronouncements that have been or may be issued and indicate their potential impact.

As part of our risk assessment procedures of the Board, we review and document the five components of internal control. A description of the components of internal control is as follows:

- Control environment sets the tone of an organization, influencing the control consciousness of its people. It is the foundation for all other components of internal control, providing discipline and structure.
- Risk assessment is the entity's identification and analysis of relevant risks to the achievement of its objectives. This forms a basis for determining how the risks should be managed.
- Control activities are the policies and procedures that help to ensure that management's directives are carried out.
- Information and communication are the means to identify, capture, and exchange information in a form and time frame that enable people to carry out their responsibilities.
- Monitoring is the process that assesses the quality of internal control performance over time.

## **Reporting to the Board**

Any findings related to internal control over financial reporting or compliance will be communicated to management during the course of the engagement and in the exit conference. This will afford management the opportunity to provide comments and additional information for consideration. As required by professional standards, we will ensure that the Board of Directors will be informed of the following:

- The Auditors' Responsibility under auditing standards generally accepted in the United States of America.
- The Auditors' responsibility under Government Auditing Standards
- Significant accounting policies
- Management judgments and accounting estimates
- Significant audit adjustments
- Other information in documents containing audited financial statements
- Disagreements with management
- Management consultation with other accountants
- Major issues discussed with management prior to retention
- Difficulties encountered in performing the audit
- Any other matter which may be important to the fair presentation of the Board's financial statements

## **VALUE ADDED SERVICES**

### **Public Authorities Reform Act of 2009**

For each of our public authority audit clients, we review their policies and procedures for compliance with the Public Authorities Reform Act of 2009 (the Act). One aspect of the Act's requirements is that the agencies submit various reports to the New York State Authorities Budget Office through the Public Authority Reporting Information System (PARIS). For several of our clients, we provide assistance in preparing and submitting the required annual reports within the required deadlines.

### **Management Consulting Services**

Understanding our client's operations and being involved throughout the year provides us with a unique opportunity to make recommendations and provide consulting services relating to operations which contributes to the success of your organization. The types of consulting services provided include, but are not limited to, the following areas:

- Assist the Board in the implementation of new pronouncements issued by the Government Accounting Standards Board.
- Review of leases and other legal agreements and interpretations of such provisions of leases and agreements.
- Ability to provide better internal control recommendations as a result of our extensive internal control audit experience with regard to governmental organizations.
- Budget reviews.
- Exempt bond financing assistance.
- Risk assessment and analysis.
- Computer needs assessments, conversion phase and implementation.
- Internal financial reporting systems.
- Assessment of Employee Benefits alternatives.
- Cash management analysis and budgeting.
- Assistance in implementing a business plan and long-range planning.
- Tax planning, consulting and preparation.
- Acquisition or valuation studies.

### **American Rescue Plan Act (ARPA)**

The EFPR Group has conducted webinars and in-person meetings with groups of Counties, Cities, Towns and Villages in order to prepare them for the upcoming requirements created by the ARPA and the administrative burden that comes with it.

One of the allowable uses of the ARPA funding is calculating revenue lost due to the pandemic. We have been engaged by several municipalities, including up to the County level, to calculate the lost revenue on their behalf. We have a team that is dedicated to performing all of our lost revenue calculation consulting engagements.

In addition to the lost revenue calculations, we also offer general consulting work in regards to the ARPA funding. This general consulting includes, but is not limited to, preparing and reviewing reporting requirements to the U.S. Department of the Treasury, assistance with accounting for the funds in accordance to the Office of the New York State Comptroller's requirements, guidance as to which activities and costs are allowable and ineligible under the federal guidance and assisting with or performing sub-recipient monitoring where required.

### **Fraud Detection and Prevention**

Stonebridge Business Partners (SBP), an EFPR Group Company, provides a full suite of business valuation, forensic accounting and litigation services to an array of business clients across the United States. In addition, they now provide a state-of-the-art confidential, nationwide ethics hotline and on-line portal. Powered by Red Flag Reporting, the SBP ethics hotline and on-line portal system is recognized as the number one method of identifying and reporting unethical or unsafe conditions so you can prevent any threat to your organization's long-term sustainability. The Association of Certified Fraud Examiners recognizes this service as the most effective method of fraud detection and prevention saving clients thousands of dollars in losses and litigation exposure.

#### The Stonebridge system provides:

- 24-hour-a-day access for employees, strategic partners and suppliers
- An easy to use and completely confidential telephone and on-line reporting system
- The ability to make reports in English and Spanish
- Certified Fraud Examiners to review each report
- Posters and wallet cards to create employee awareness and facilitate quick response
- Quarterly emails to employees and newsletters to management
- A live fraud awareness seminar and pre-recorded issue awareness webinars
- Detained reports to pre-designated members of your organization
- "Reduced Risk" and increased "Peace of Mind"

### **SCOPE OF SERVICES**

The following is an outline of services to be provided to the Niagara Falls Water Board for the years ending December 31, 2023, 2024 and 2025:

- Audit the financial statements in accordance with auditing standards generally accepted in the United States of America, the standards applicable to financial audits contained in Government Auditing Standards, issued by the Comptroller General of the United States. The primary purpose of this audit is the expression of an opinion as to the fair presentation of the financial statements in conformity with accounting principles generally accepted in the United States of America.
- Issue a report on internal control over financial reporting and a report on compliance and other matters based on an audit of financial statements performed in accordance with Government Auditing Standards. This report will communicate any reportable conditions and instances of noncompliance found during our audit.

- Prepare a letter to management detailing comments and suggestions for improvements in internal control or general management techniques which come to our attention during the audit. We will review and explain all observations and recommendations so that appropriate changes may be implemented.
- Prepare a report as required by Title Two of the Official Compilation of Codes, Rules and Regulations of the State of New York to ensure compliance with investment guidelines including New York State Office of the Comptroller Investment Guidelines for Public Authorities and Section 2925 (3)(F) of the State of New York Public Authorities Law - Investments of Public Authorities. We will prepare a separate compliance report on investment practices and the Investment Guidelines of the Office of the State Comptroller, as well as any other applicable laws, regulations, or other guidelines.
- Attend a meeting with the Board of Directors at a regularly scheduled meeting to review the results of our audit of the financial statements.
- Maintain contact throughout the year to discuss: (a) changes in accounting which could affect the Board and (b) the progress toward fulfilling current needs and future objectives.

**TIMING AND COST**

Upon receiving notice of appointment as auditors, we will meet with you and establish a definite time program for the performance of services. The time program will be established in such a way to ensure that work is efficient and structured to avoid disrupting the day-to-day routine duties of your staff. The following is an estimated timetable related to performance of our services on an annual basis:

<u>Service</u>	<u>Deadline</u>
Complete interim fieldwork	By December 31 <sup>st</sup>
Commencement of final fieldwork	By February 1 <sup>st</sup>
Complete final fieldwork	By February 15 <sup>th</sup>
Issue draft reports	By March 15 <sup>th</sup>
Issue final reports	Upon approval

Our fee quote is based upon the estimated time we will spend on the engagement and the qualifications of personnel that will be assigned. On the basis of our extensive experience with public benefit corporations and other governmental organizations similar to yours, we have determined the fees that we will charge for the required services for the years ending December 31, 2023, 2024 and 2025 to be as follows:

December 31, 2023	\$ 24,000
December 31, 2024	25,000
December 31, 2025	<u>26,000</u>

These are the ALL-INCLUSIVE FEES to be charged to the Board and include all costs, including report reproduction and similar expense (travel, phone, clerical, postage, etc.).

We consider ourselves not only auditors but also advisors to our clients. Accordingly, we encourage our clients to contact us throughout the year to discuss any technical matters or other issues that arise. We consider this service an integral part of our overall client relationship and accordingly, do not bill separately for any of these questions.

In the event additional services outside the scope of services listed in this proposal are requested by the Niagara Falls Water Board, the discounted hourly rates to be billed for these services for the year ending December 31, 2023 will be as follows:

Partner	\$ 295
Senior accountant	120
Staff accountant	<u>95</u>

Any such additional work shall be performed **ONLY** if set forth in an addendum to the contract between the Board and the EFPR Group, CPAs, PLLC.

#### **LITIGATION, DEBARMENT, BANKRUPTCY**

The EFPR Group, CPAs, PLLC has never been debarred or suspended by any government entity from entering contracts with it. The EFPR Group, CPAs, PLLC has never been found not responsible by any government entity or declared in default or terminated for cause from any contract, or had any contract cancelled for cause. The EFPR Group, CPAs, PLLC has not been required to pay liquidated damages on a contract.

The EFPR Group, CPAs, PLLC has never filed for bankruptcy or been the subject of an involuntary bankruptcy proceeding.

The EFPR Group, CPAs, PLLC has not been a party to any legal action or government investigation related to the Firm's business practices, or alleging that any of the Firm's agents or employees committed any act of fraud, collusion, bid rigging, price fixing, or bribery.

#### **INSURANCE CERTIFICATES**

The EFPR Group, CPAs, PLLC currently has insurance coverage that meets all requirements of the Niagara Falls Water Board. Specifically, we carry Commercial General Liability Insurance with an amount of \$2,000,000 combined single limit and \$4,000,000 in the aggregate; Comprehensive Business Automobile Insurance with an amount of \$1,000,000 each accident; and Professional Liability Insurance with an amount of \$3,000,000 each occurrence and \$3,000,000 in the aggregate. Upon award of contract, we will provide to the Board the appropriate insurance certificates naming the Board as an additional insured.

#### **OTHER SIGNIFICANT INFORMATION**

- **Technology** - All of our field staff are equipped with laptop computers and have access to various software packages and databases (e.g. data extraction software, flowchart software, Microsoft Office, etc.) and other electronic means to ensure that the audit is performed in the most efficient manner.
- **Continuing Education** - With regard to continuing professional education, each of our staff members is required to complete an annual minimum of 40 hours of continuing education programs approved by the American Institute of Certified Public Accountants. Additionally, since we perform audits in accordance with Government Auditing Standards (over 350 each year), our staff members must complete at least 24 of the 80 hours (over a two-year period) of continuing education in subjects directly related to the government environment and government auditing.



- Affirmative Action - The EFPR Group, CPAs, PLLC is an equal opportunity employer and as such possesses a firm commitment to affirmative action and to hiring only the best-qualified candidates regardless of gender or ethnic origin. Our Firm does not discriminate against any employee or applicant for employment because of race, creed, color, national origin, sex, age, disability or marital status.

\* \* \* \* \*

We would consider it a distinct privilege to provide professional services as outlined in this letter or any additional services you may desire. Please contact us if you have any questions regarding this letter.

A copy of this letter is enclosed; if the terms of this proposal are satisfactory to you please sign the copy and return it to me at your convenience.

ACCEPTED:

EFPR GROUP, CPAs, PLLC

NIAGARA FALLS WATER BOARD

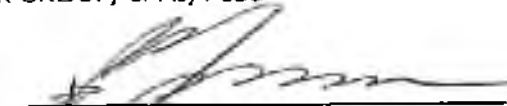
By:   
Douglas E. Zimmerman, CPA  
Partner

By: \_\_\_\_\_

Date: September 8, 2023

Date: \_\_\_\_\_

## **Appendix A**

### **Detailed Resumes of Key Members of the Firm's Government Audit Practice Group**

EFPR GROUP CPAS PLLC

**GENERAL INFO**

Address

100 SOUTH CLINTON AVENUE SUITE 1500 ROCHESTER NY 146041801

Business Entity (3)

Professional Service Limited Liability Company

Company ID

109311

Initial Filing Date

July 07, 2015

Current Through

June 30, 2027

Members/Managers:

<b>License Number</b>	<b>Name</b>
<u>045109</u>	VENISKEY DAVID P
<u>052478</u>	JACOB MARK D
<u>052811</u>	KIEL PAUL E
<u>060798</u>	ZIMMERMAN DOUGLAS EDWARD
<u>063844</u>	DAVIS RICHARD JAMES
<u>066232</u>	HILL KEVIN CURTIS
<u>066587</u>	PETERSON WILLIAM FRANK JR
<u>066732</u>	DILUIGI MARIO
<u>069897</u>	MARASCO JAMES IMMANUEL
<u>072798</u>	BLISS GINA B
<u>073803</u>	URBAN DAVID ANDREW
<u>074002</u>	KIBLIN JENNIFER
<u>078202</u>	RUTECKI MAUREEN MACDONALD
<u>078580</u>	OSBORN KELLY ANN
<u>080111</u>	WILLIAMS ROBERT JAMES
<u>081297</u>	TOMEI VINCENT JAMES III
<u>083963</u>	DOODY MICHAEL ROBERT
<u>090478</u>	JOHNSTON CHRISTOPHER MICHAEL
<u>098396</u>	COSTILOW JOHN S
<u>100088</u>	NILES THOMAS FRANCIS
<u>102348</u>	KLEEHAMMER VICTORIA LYNN
<u>111798</u>	BROCK COURTNEY S
<u>112212</u>	JENSEN BRENT M
<u>114640</u>	VENISKEY ANDREW R
<u>115256</u>	PIPER JASON MATTHEW
<u>116551</u>	SMITH THOMAS EDMUND
<u>117823</u>	HOFFMAN JOSHUA MICHAEL
<u>124639</u>	FOX ANDREW DAVID
<u>130169</u>	EMICH RICHELE PAULA



September 5, 2023 02:49 PM (ET)

<https://www.op.nysed.gov/verification-search?pscNumber=109311&professionCode=007>

**Douglas E. Zimmerman, CPA**  
**Partner**

Doug has over 36 years of public accounting experience. He currently functions as a Partner of the EFPR Group, CPAs, PLLC and has responsibility for providing audit, accounting and consulting services for numerous public benefit corporations and other governmental organizations. He has been the partner or engagement review partner on many of the engagements listed in Appendix B of our proposal.

Doug received a Bachelor of Science degree in Accounting from State University of New York College at Geneseo in 1986. He was licensed in New York State as a Certified Public Accountant in 1989, the State of Florida in 2015, and the State of Massachusetts in 2020.

Doug has experience providing audit services to numerous public benefit corporations, including New York State Urban Development Corporation d/b/a Empire State Development, Lower Manhattan Development Corporation, Monroe County Water Authority, New York Convention Center Operating Corporation and New York State Olympic Regional Development Authority.

**Professional Affiliations**

American Institute of Certified Public Accountants (AICPA)  
New York State Society of Certified Public Accountants (NYSSCPA)



**PRACTICE AREAS**  
Governmental Accounting  
Higher Education  
Nonprofit

**EDUCATION**  
SUNY Geneseo – B.S., Accounting,  
1986

**CONTACT**  
PHONE (716) 204-5704  
CELL (716) 445-4018  
FAX (716) 634-0764  
E-MAIL  
[dzimmerman@efprgroup.com](mailto:dzimmerman@efprgroup.com)

ZIMMERMAN DOUGLAS EDWARD  
LICENSEE INFO

Address

RUSHVILLE NY

Profession

Certified Public Accountancy (007)

License Number

060798

Date of Licensure

March 29, 1989

Status

Registered

Registered through Date

August 31, 2026

Additional Qualifications

- Not applicable in this profession



September 5, 2023 02:49 PM (ET)

<https://www.op.nysed.gov/verification-search?licenseNumber=060798&professionCode=007>

**John S. Costilow, CPA**  
**Partner**

John has over 16 years of public accounting experience. He currently functions as a Partner of the Firm and has responsibility for providing audit, accounting and consulting services for numerous public benefit corporations and other governmental organizations.

John received a Bachelor of Science degree in Accounting from State University of New York College at Buffalo in 2006. He was licensed in New York State as a Certified Public Accountant in 2008.

John has experience providing audit services to numerous public benefit corporations, including Islip Resource Recovery Agency, Roosevelt Island Operation Corporation, Niagara Falls Urban Renewal Agency, N.F.C. Development Corporation, and Sleepy Hollow Local Development Corporation.

**Professional Affiliations**

American Institute of Certified Public Accountants (AICPA)  
New York State Society of Certified Public Accountants (NYSSCPA)



**PRACTICE AREAS**  
Governmental Accounting  
Higher Education

**EDUCATION**  
SUNY Buffalo – B.S., Accounting,  
2006

**CONTACT**  
**PHONE** (716) 204-5719  
**FAX** (716) 634-0764  
**E-MAIL**  
[jcostilow@cfprgroup.com](mailto:jcostilow@cfprgroup.com)

COSTILOW JOHN S

LICENSEE INFO

Address

WILLIAMSVILLE NY

Profession

Certified Public Accountancy (007)

License Number

098396

Date of Licensure

October 15, 2008

Status

Registered

Registered through Date

May 31, 2026

Additional Qualifications

- Not applicable in this profession



September 5, 2023 02:49 PM (ET)

<https://www.op.nysed.gov/verification-search?licenseNumber=116551&professionCode=007>

**Brent M. Jensen, CPA**

**Partner**

Brent has over 16 years of public accounting experience. He currently functions as a Partner of the Firm and has responsibility for providing audit, accounting and consulting services for numerous public benefit corporations and other governmental organizations.

Brent received a Bachelor of Science degree in Accounting from State University of New York College at Buffalo in 2006. He was licensed in New York State as a Certified Public Accountant in 2013.

Brent has experience providing audit services to numerous public benefit corporations, including New York State Urban Development Corporation d/b/a Empire State Development, Lower Manhattan Development Corporation, Trust for Cultural Resources of the City of New York, Warren County Local Development Corporation, and New York City Tax Lien Trusts.

**Professional Affiliations**

American Institute of Certified Public Accountants (AICPA)  
Government Finance Officers Association (GFOA)



**PRACTICE AREAS**

Governmental Accounting  
Higher Education

**EDUCATION**

SUNY Buffalo – B.S., Accounting,  
2006

**CONTACT**

PHONE (716) 204-5749

FAX (716) 634-0764

E-MAIL

[bjensen@efprgroup.com](mailto:bjensen@efprgroup.com)



**Thomas E. Smith, CPA**  
**Partner**

Tom has over 11 years of public accounting experience. He currently functions as a Partner of the Firm and has responsibility for providing audit, accounting and consulting services for numerous public benefit corporations and other governmental organizations.

Tom received a Bachelor of Science degree in Accounting in 2011 and a Master of Science degree in Accounting in 2012 from State University of New York College at Buffalo. He was licensed in New York State as a Certified Public Accountant in 2015 and in Florida in 2021.

Tom has experience providing audit services to numerous public benefit corporations, including Monroe County Water Authority, Broome County Land Bank, Land Reutilization Corporation of the Capital Region, Washington County Local Development Corporation, Warran and Washington Counties Industrial Development Agency, and Lake Champlain-Lake George Regional Planning Board.

**Professional Affiliations**

American Institute of Certified Public Accountants (AICPA)  
Government Finance Officers Association (GFOA)



**PRACTICE AREAS**  
Governmental Accounting  
Higher Education

**EDUCATION**  
SUNY Buffalo – B.S., Accounting,  
2011  
SUNY Buffalo - M.S., Accounting,  
2012

**CONTACT**  
**PHONE** (716) 204-5774  
**FAX** (716) 634-0764  
**E-MAIL**  
[tsmith@efprgroup.com](mailto:tsmith@efprgroup.com)

**David S. Gabel, CPA**  
**Director**

Dave has over 34 years of public accounting experience. He currently functions as a Director of the Firm and has responsibility for providing audit, accounting and consulting services for numerous public benefit corporations and other governmental organizations.

Dave received a Bachelor of Science degree in Accounting from State University of New York College at Fredonia in 1988. He was licensed in New York State as a Certified Public Accountant in 1990.

Dave has experience providing audit services to numerous public benefit corporations, including Village of Hempstead Community Development Agency, Orleans County Industrial Development Agency, New York State Bridge Authority, Kingston City Land Bank, New York Convention Center Operating Corporation, New York State Olympic Regional Development Authority and Ogdensburg Bridge and Port Authority.

**Professional Affiliations**

American Institute of Certified Public Accountants (AICPA)  
New York State Society of Certified Public Accountants (NYSSCPA)  
Affordable Housing Association of Certified Public Accountants (AHACPA)



**PRACTICE AREAS**  
Government  
Nonprofit  
Construction and Real Estate

**EDUCATION**  
SUNY Fredonia – B.S., Accounting,  
1988

**CONTACT**  
**PHONE** (716) 204-5706  
**FAX** (716) 634-0764  
**E-MAIL**  
[dgabel@efprgroup.com](mailto:dgabel@efprgroup.com)

**Jeffrey N. Jones, MSA**  
**Director**

Jeff has over eight years of public accounting experience. He currently functions as a Director of the Firm and has responsibility for providing audit, accounting and consulting services for numerous public benefit corporations and other governmental organizations.

Jeff received a Bachelor of Science and a Master of Science degree in Accountancy from Daemen College in 2014.

Jeff has experience providing audit services to numerous public benefit corporations, including New York State Urban Development Corporation d/b/a Empire State Development and Lower Manhattan Development Corporation.

**Community Affiliations**  
Hull House Foundation, *Board Trustee*



**PRACTICE AREAS**  
Governmental Accounting  
Nonprofit

**EDUCATION**  
Daemen College – B.S.,  
Accountancy  
Daemen College - M.S.A.,  
Accountancy, 2014

**CONTACT**  
**PHONE** (716) 204-5775  
**FAX** (716) 634-0764  
**E-MAIL**  
[jjones@efprgroup.com](mailto:jjones@efprgroup.com)

**Brian D. Sawma**  
**Director**

Brian has over eight years of public accounting experience. He currently functions as a Director of the Firm and has responsibility for providing audit, accounting and consulting services for numerous public benefit corporations and other governmental organizations.

Brian received a Bachelor of Business Administration degree in Accounting in 2013 and a Masters of Business Administration degree in Accounting in 2016 from Niagara University.

Brian has experience providing audit services to numerous public benefit corporations, including Washington County Local Development Corporation, Warren and Washington Counties Industrial Development Agency, Lake Champlain-Lake George Regional Planning Board, and New York Convention Center Operating Corporation.

**Community Affiliations**

716 Promoting Animal Welfare and Safety, Inc., *Board Treasurer*



**PRACTICE AREAS**

Governmental Accounting  
Higher Education  
Nonprofit

**EDUCATION**

Niagara University – B.B.A.,  
Accounting, 2013  
Niagara University - M.B.A.,  
Accounting, 2016

**CONTACT**

PHONE (716) 204-5733

FAX (716) 634-0764

E-MAIL

[bsawma@efprgroup.com](mailto:bsawma@efprgroup.com)

**Michael Prentice**  
**Supervisor**

Mike has over five years of public accounting experience. He currently functions as a Supervisor of the Firm and has responsibility for providing audit, accounting and consulting services for numerous public benefit corporations and other governmental organizations.

Mike received a Bachelor of Science degree in Accounting and a Bachelor of Science degree in Finance from State University of New York College at Fredonia in 2017.

Mike has experience providing audit services to numerous public benefit corporations, including Niagara Falls Urban Renewal Agency, N.F.C. Development Corporation, Broome County Land Bank, Chemung County Land Bank, and Kingston City Land Bank.



**PRACTICE AREAS**  
Governmental Accounting  
Higher Education

**EDUCATION**  
SUNY Fredonia - B.S., Accounting,  
2017  
SUNY Fredonia - B.S., Finance,  
2017

**CONTACT**  
**PHONE** (716) 204-5728  
**FAX** (716) 634-0764  
**E-MAIL**  
[mprentice@efprgroup.com](mailto:mprentice@efprgroup.com)

**Justin Pepe**  
**Senior Accountant**

Justin has over two years of public accounting experience. He currently functions as a Senior Accountant for the Firm and has responsibility for providing audit, accounting and consulting services for numerous public benefit corporations and governmental organizations.

Justin received a Bachelor of Science degree in Finance from the University at Buffalo in 2019 and a Master of Business Administration degree in Professional Accounting from Canisius College in 2021.

Justin has experience providing audit services to numerous public benefit corporations, including Islip Resource Recovery Agency and Ogdensburg Bridge and Port Authority.



**PRACTICE AREAS**

Higher Education  
Governmental Accounting

**EDUCATION**

University at Buffalo - B.S.,  
Finance, 2019  
Canisius College - M.B.A.,  
Professional Accounting, 2021

**CONTACT**

**PHONE** (716) 204-5758

**FAX** (716) 634-0764

**E-MAIL**

[jpepe@efprgroup.com](mailto:jpepe@efprgroup.com)

**Jason Cukierski**  
**Senior Accountant**

Jason has over two years of public accounting experience. He currently functions as a Senior Accountant in the Firm and has responsibility for providing audit, accounting and consulting services for numerous public benefit corporations and other governmental organizations.

Jason received a Bachelor of Science degree in Business Administration with concentrations in Finance and Management Information Systems in 2014 and a Juris Doctor degree with concentrations in Finance and Development and Intellectual Property and Privacy Law in 2017 from University at Buffalo.

Jason has experience providing audit services to numerous public benefit corporations, including New York State Urban Development Corporation d/b/a Empire State Development, Lower Manhattan Development Corporation and Sleepy Hollow Local Development Corporation.



**PRACTICE AREAS**  
Governmental Accounting  
Higher Education

**EDUCATION**  
University at Buffalo – B.S.,  
Business Administration, 2014  
University at Buffalo - J.D., 2017

**CONTACT**  
**PHONE** (716) 204-5769  
**FAX** (716) 634-0764  
**E-MAIL**  
[jcukierski@cfprgroup.com](mailto:jcukierski@cfprgroup.com)

**Aaron Woodward**  
**Senior Accountant**

Aaron has over two years of public accounting experience. He currently functions as a Senior Accountant in the Firm and has responsibility for providing audit, accounting and consulting services for numerous public benefit corporations and other governmental organizations.

Aaron received a Bachelor of Science degree in Accounting from State University of New York College at Brockport and a Master of Science degree in Accounting from State University of New York College at Brockport.

Aaron has experience providing audit services to New York State Urban Development Corporation d/b/a Empire State Development and Trust for Cultural Resources of the City of New York



**PRACTICE AREAS**  
Governmental Accounting  
Higher Education

**EDUCATION**  
SUNY Brockport - B.S., Accounting  
SUNY Brockport - M.S.,  
Accounting

**CONTACT**  
PHONE (716) 204-5720  
FAX (716) 634-0764  
E-MAIL  
[awoodward@efprgroup.com](mailto:awoodward@efprgroup.com)



## **Appendix B**

### **Partial Government Client List**

**PARTIAL LISTING OF GOVERNMENTAL  
ORGANIZATIONS WHICH ARE OUR CLIENTS**

- Amagansett Union Free School District
- \* Amsterdam Housing Authority
- Binghamton-Johnson City Joint Sewage Board
- Borough of Sayre
- Borough of South Waverly
- \* Brentwood Union Free School District
- Broome County Land Bank Corporation
- \* Buffalo Municipal Housing Authority
- \* Canton Area School District
- \* Canton Housing Authority
- Cayuga County Health Insurance Consortium
- Central Falls School District
- Chelsea Fire District
- Chemung County Property Development Corporation
- Chemung Tobacco Asset Securitization Corporation
- \* City of Beacon
- \* City of Destin
- City of Lackawanna
- \* City of Niagara Falls
- \* City of Oneonta Housing Authority
- City of Port Richey
- \* City School District of the City of Albany
- \* City School District of New Rochelle
- City University of New York (CUNY)
- \* Cohoes Housing Authority
- \* Cornwall Central School District
- \* Cortland Housing Authority
- \* County of Allegany
- \* County of Chemung
- \* County of Delaware
- \* County of Lewis
- \* County of Orleans
- \* County of Saratoga
- \* County of Washington
- Deferred Compensation Plan for the Employees of Chemung County
- Deferred Compensation Plan for the Employees of Delaware County
- Deferred Compensation Plan for the Employees of the Islip Resource Recovery Agency
- Deferred Compensation Plan for the Employees of Monroe County Water Authority

\* Audit conducted in compliance with the provisions of Office of Management and Budget (OMB) Uniform Administrative Requirements, Cost Principles and Audit Requirements for Federal Awards.

**PARTIAL LISTING OF GOVERNMENTAL  
ORGANIZATIONS WHICH ARE OUR CLIENTS**

Deferred Compensation Plan for the Employees of the Town of Huntington  
Deferred Compensation Plan for the Employees of the Town of Ithaca  
Deferred Compensation Plan for the Employees of the Town of Union  
Dunkirk Local Development Corporation  
Dutchess County Department of Public Works  
Dutchess County Soil and Water Conservation District  
\* East Hampton Union Free School District  
\* East Quogue Union Free School District  
\* Elmsford Union Free School District  
\* Empire State Development Corporation  
\* Enlarged City School District of Troy  
Fire District No. 1 - Town of Elmira  
Fire District No. 3 of the Town of Plattsburgh  
Fishers Island Ferry District  
Fishers Island Union Free School District  
Fort Montgomery Fire District  
\* Franklin County Regional Housing and Redevelopment Authority  
Genesee Tobacco Asset Securitization Corporation  
\* Geneva Housing Authority  
\* Glen Cove Industrial Development Agency  
\* Glen Cove Community Development Agency  
\* Gloversville Housing Authority  
Greene County Economic Development Corporation  
Greenwood Lake Joint Fire District  
HealthSource RI Trust  
\* Harlem Community Development Corporation  
Harrietstown Housing Authority  
\* Hempstead Union Free School District  
Henrietta Fire District  
\* Herkimer Housing Authority  
\* Hudson River Park Trust  
\* Ilion Housing Authority  
\* Ithaca Housing Authority  
Lake Champlain-Lake George Regional Planning Board  
Land Reutilization Corporation of the Capital Region  
LeRoy Fire District  
Long Beach Housing Authority  
\* Lower Manhattan Development Corporation

\* Audit conducted in compliance with the provisions of Office of Management and Budget (OMB) Uniform Administrative Requirements, Cost Principles and Audit Requirements for Federal Awards.

**PARTIAL LISTING OF GOVERNMENTAL  
ORGANIZATIONS WHICH ARE OUR CLIENTS**

- Lucas Metropolitan Housing Authority
- \* Merrick Union Free School District
- Monroe County Department of Transportation
- Monroe County Water Authority
- Morrisonville Fire District
- \* Nashua Housing and Redevelopment Authority
- Nassau County Deferred Compensation Plan
- New Rochelle Municipal Housing Authority
- New York City Administration for Children's Services
- New York City Department of Corrections
- New York City Department of Social Services
- New York City Department for the Aging
- New York City Department of Citywide Administrative Services
- New York City Department of Health and Mental Hygiene
- New York City Department of Homeless Services
- New York City Department of Probation
- New York City Human Resources Administration
- New York City Tax Lien Trusts (four trusts)
- \* New York Convention Center Development Corporation
- New York Convention Center Operating Corporation (Javits Center)
- \* New York Empowerment Zone Corporation
- \* New York Job Development Authority
- New York State Assembly
- New York State Affordable Housing Corporation
- New York State Bridge Authority
- New York State Dairy Promotion Order
- \* New York State Department of Taxation and Finance
- New York State Department of Transportation
- New York State Division of the Budget
- New York State Executive Chamber
- New York State Homeless Housing Assistance Corporation
- New York State Legislative Bill Drafting Commission
- New York State Office for People With Developmental Disabilities
- New York State Office of Alcoholism and Substance Abuse Services
- New York State Office of the State Comptroller
- New York State Office of General Services
- New York State Olympic Regional Development Authority
- New York State Senate

\* Audit conducted in compliance with the provisions of Office of Management and Budget (OMB) Uniform Administrative Requirements, Cost Principles and Audit Requirements for Federal Awards.

**PARTIAL LISTING OF GOVERNMENTAL  
ORGANIZATIONS WHICH ARE OUR CLIENTS**

- New York State Unified Court System
- \* New York State Urban Development Corporation
- \* Newark Housing Authority
  - N.F.C. Development Corporation
  - Niagara Falls Urban Renewal Agency
  - Niagara-Orleans Regional Land Improvement Corporation
  - Northern Tier Career Center
- \* Ogdensburg Bridge and Port Authority
  - Ontario County Industrial Development Agency
- \* Orleans County Industrial Development Agency
  - Palisades Interstate Park Commission New Jersey Section and New York Section
- \* Pawling Central School District
  - Pine Hill Fire District No. 5
- \* Port Jefferson Union Free School District
  - Poughkeepsie Public Library district
  - Quassaick Bridge Fire District
  - Remsenburg-Speonk Union Free School District
- \* Rhinebeck Central School District
- \* Rochester Housing Authority
- \* Rome Housing Authority
- \* Rockville Centre Union Free School District
- \* Roosevelt Island Operating Corporation
- \* Roosevelt Union Free School District
- \* St. Johnsville Housing Authority
- \* Sachem Central School District
- \* Sayre Area School District
  - Sayre Public Library
- \* Scarsdale Union Free School District
- \* Schuylerville Central School District
- \* Seneca Nation Housing Authority
- \* Shenendehowa Central School District
  - South Waverly Municipal Authority
  - Southern Cayuga Lake Intermunicipal Water Commission
  - Springs Union Free School District
  - Steuben County Economic Development Corporation
  - Steuben County Industrial Development Agency
- \* Suffern Central School District
  - Suffolk County 401(a) Terminal Pay Plan

\* Audit conducted in compliance with the provisions of Office of Management and Budget (OMB) Uniform Administrative Requirements, Cost Principles and Audit Requirements for Federal Awards.

**PARTIAL LISTING OF GOVERNMENTAL  
ORGANIZATIONS WHICH ARE OUR CLIENTS**

- Suffolk County Department of Public Works
- \* Syracuse Housing Authority
- \* Three Village Central School District
- Tioga County Local Development Corporation
- Tobacco Settlement Financing Corporation
- Town of Beekman
- \* Town of Cortlandt
- Town of Elmira
- Town of Erwin
- Town of Fishkill
- Town of Gates
- \* Town of German Flatts
- \* Town of Grand Island
- Town of Hempstead Sanitary District Number Two
- Town of Hempstead Sanitary District Number Seven
- \* Town of Huntington Housing Authority
- Town of Ithaca
- Town of Lumberland
- Town of Mamaroneck
- Town of Mexico
- Town of Plattsburgh
- \* Town of Southeast
- Town of Ulster
- Town of Union
- Trust for Cultural Resources of the City of New York
- \* Ulster County Community College
- University at Albany Athletics Department
- \* Utica Municipal Housing Authority
- Valley Joint Sewer Authority
- \* Vernon-Verona-Sherrill Central School District
- Village of Cold Spring
- \* Village of Delhi
- Village of Heuvelton
- Village of Montebello
- Village of South Glens Falls
- Washington Tobacco Asset Securitization Corporation
- Waterfront Commission of New York Harbor
- \* Watertown Housing Authority

\* Audit conducted in compliance with the provisions of Office of Management and Budget (OMB) Uniform Administrative Requirements, Cost Principles and Audit Requirements for Federal Awards.

**PARTIAL LISTING OF GOVERNMENTAL  
ORGANIZATIONS WHICH ARE OUR CLIENTS**

Wayne County Civic Facility Development Corporation  
Wayne County Industrial Development Agency  
West Genesee Central School District  
\* Westbury Union Free School District  
\* William Floyd Union Free School District  
Williamsville Central School District  
\* Winooski Housing Authority

\* Audit conducted in compliance with the provisions of Office of Management and Budget (OMB) Uniform Administrative Requirements, Cost Principles and Audit Requirements for Federal Awards.

## **Appendix C**

### **Peer Review Letter**





Lisa M. Altschaffl, CPA  
Jeffrey P. Anzovino, CPA, MSA  
Cole P. Boehner, CPA  
Charles A. Deluzio, CPA

Joseph E. Petrillo, CPA  
Stacey A. Sanders, CPA, CSEP  
Daniel W. Wilkins, CPA

### Report on the Firm's System of Quality Control

June 8, 2020

To the Partners of EFPR Group LLP  
and the National Peer Review Committee

We have reviewed the system of quality control for the accounting and auditing practice of EFPR Group LLP (the firm) in effect for the year ended November 30, 2019. Our peer review was conducted in accordance with the Standards for Performing and Reporting on Peer Reviews established by the Peer Review Board of the American Institute of Certified Public Accountants (Standards).

A summary of the nature, objectives, scope, limitations of, and the procedures performed in a System Review as described in the Standards may be found at [www.aicpa.org/prsummary](http://www.aicpa.org/prsummary). The summary also includes an explanation of how engagements identified as not performed or reported in conformity with applicable professional standards, if any, are evaluated by a peer reviewer to determine a peer review rating.

#### Firm's Responsibility

The firm is responsible for designing a system of quality control and complying with it to provide the firm with reasonable assurance of performing and reporting in conformity with applicable professional standards in all material respects. The firm is also responsible for evaluating actions to promptly remediate engagements deemed as not performed or reported in conformity with professional standards, when appropriate, and for remediating weaknesses in its system of quality control, if any.

#### Peer Reviewer's Responsibility

Our responsibility is to express an opinion on the design of the system of quality control and the firm's compliance therewith based on our review.

#### Required Selections and Considerations

Engagements selected for review included engagements performed under *Government Auditing Standards*, including compliance audits under the Single Audit Act and audits of employee benefit plans. As a part of our peer review, we considered reviews by regulatory entities as communicated by the firm, if applicable, in determining the nature and extent of our procedures.

#### Opinion

In our opinion, the system of quality control for the accounting and auditing practice of EFPR Group LLP, in effect for the year ended November 30, 2019, has been suitably designed and complied with to provide the firm with reasonable assurance of performing and reporting in conformity with applicable professional standards in all material respects. Firms can receive a rating of *pass*; *pass with deficiency(ies)* or *fail*. EFPR Group LLP has received a peer review rating of *pass*.

*Deluzio & Company LLP*

Deluzio & Company LLP



**Appendix D**

**Required Forms**

APPENDIX A, FORM No. 1

**ACKNOWLEDGEMENT OF ADDENDA**

RFP TITLE: RFP No. 2023-03 Annual Audit Services  
(Write the RFP No. and Title on the Line Above)

DIRECTIONS: Complete Part I or Part II, whichever is applicable.

PART I: LISTED BELOW ARE THE DATES OF ISSUE FOR EACH  
ADDENDUM RECEIVED IN CONNECTION WITH THIS RFP:

ADDENDUM # 1: DATED \_\_\_\_\_, 20\_\_

ADDENDUM # 2: DATED \_\_\_\_\_, 20\_\_

ADDENDUM # 3: DATED \_\_\_\_\_, 20\_\_

ADDENDUM # 4: DATED \_\_\_\_\_, 20\_\_

ADDENDUM # 5: DATED \_\_\_\_\_, 20\_\_

ADDENDUM # 6: DATED \_\_\_\_\_, 20\_\_

PART II: \_\_\_\_\_ INITIAL HERE IF NO ADDENDUM WAS RECEIVED  
IN CONNECTION WITH THIS RFP INITIAL HERE

DATE: 9 / 8 / 2023

PROPOSER (SIGNATURE):

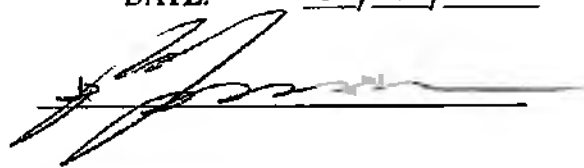

PROPOSER (NAME):

Douglas E. Zimmerman, CPA

PROPOSER (FIRM):

EFPR Group, CPAs, PLLC

APPENDIX A, FORM No. 2

**CERTIFICATE OF NON-COLLUSION**

Pursuant to New York State Public Authorities Law, Article 9, Title 4, Section 2878, the undersigned proposer hereby subscribes and affirms as true, under the penalties of perjury, the following statement of non-collusion:

By submission of this proposal, each proposer and each person signing on behalf of any proposer certifies, and in the case of a joint proposal each party thereto certifies as to its own organization, under penalty of perjury, that to the best of his/her knowledge and belief:

- (1) The prices in this proposal have been arrived at independently without collusion, consultation, communication, or agreement, for the purpose of restricting competition, as to any matter relating to such prices with any other proposer or with any competitor;
- (2) Unless otherwise required by law, the prices which have been quoted in this proposal have not been knowingly disclosed by the proposer and will not knowingly be disclosed by the proposer prior to opening, directly or indirectly, to any other proposer or to any competitor; and,
- (3) No attempt has been made or will be made by the proposer to induce any other person, partnership, or corporation to submit or not to submit a proposal for the purpose of restricting competition.

DATE: 9 / 8 / 2023

PROPOSER (SIGNATURE):

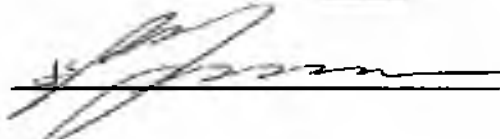

PROPOSER (NAME):

Douglas E. Zimmerman, CPA

PROPOSER (FIRM):

EFPR Group, CPAs, PLLC

STATE OF New York )

) ss.:

COUNTY OF Erie )

On the 8th day of September, 2023, before me, the undersigned, a Notary Public in and for said state, personally appeared Douglas E. Zimmerman, CPA as a representative of EFPR Group, CPAs, PLLC personally known to me or proved to me on the basis of satisfactory evidence to be the individual whose name is subscribed to the within instrument and acknowledged to me that he/she executed the same in his/her capacity, and that by his/her signature on the instrument, the entity on behalf of which the individual acted executed the instrument.



Notary Public  
DEBORAH A SCHALL  
Notary Public, State of New York  
Registration No. 01SC3034524  
Qualified in Erie County  
My Commission Expires November 07, 2024





**NOTICE OF NFWB'S RIGHT TO TERMINATE**

**The NFWB reserves the right to terminate a Contract (including any lease, license, entry permit, or sale documents) in the event it is found that the certification filed by the Proposer, in accordance with New York State Finance Law §139-k, was intentionally false or intentionally incomplete. Upon such finding, the NFWB may exercise its termination right by providing written notification to the Bidder/Proposer in accordance with the written notification terms of the Contract.**

**Proposer's Affirmation and Certification**

By signing below, the Proposer:

- a) Affirms that the Proposer understands and agrees to comply with the policy regarding permissible contacts in accordance with New York State Finance Law Sections 139-j and 139-k.
- b) Certifies that all information provided to the NFWB with respect to New York State Finance Law §139-j and §139-k is complete, true and accurate.

DATE: 9 / 8 / 2023

PROPOSER (SIGNATURE):



PROPOSER (NAME):

Douglas E. Zimmerman, CPA

PROPOSER (FIRM):

EFPR Group, CPAs, PLLC

STATE OF New York )

) ss.:

COUNTY OF Erie )

On the 8th day of September, 2023, before me, the undersigned, a Notary Public in and for said state, personally appeared Douglas E. Zimmerman, CPA as a representative of EFPR Group, CPAs, PLLC, personally known to me or proved to me on the basis of satisfactory evidence to be the individual whose name is subscribed to the within instrument and acknowledged to me that he/she executed the same in his/her capacity, and that by his/her signature on the instrument, the entity on behalf of which the individual acted executed the instrument.



Notary Public

DEBORAH A SCHALI Notary Public, State of New York Registration No. 01SC9034524 Qualified in Erie County My Commission Expires November 07, 2026
---

APPENDIX A, FORM No. 4

**EQUAL EMPLOYMENT OPPORTUNITY ("EEO")  
POLICY STATEMENT AND AGREEMENT**

Proposer hereby agrees to the following EEO policy with respect to its work on any contract awarded in connection with this RFP:

- a) This organization will not discriminate against any employee or applicant for employment because of race, creed, color, national origin, sex, age, disability or marital status, will undertake or continue existing programs of affirmative action to ensure that minority group members are afforded equal employment opportunities without discrimination, and shall make and document its conscientious and active efforts to employ and utilize minority group members and women in its work force on Niagara Falls Water Board ("Water Board") contracts.
- b) This organization shall state in all solicitations or advertisements for employees that in the performance of the Water Board contract all qualified applicants will be afforded equal employment opportunities without discrimination because of race, creed, color, national origin, sex, disability or marital status.
- c) At the request of the Water Board, this organization shall request each employment agency, labor union, or authorized representative of workers with which it has a collective bargaining or other agreement or understanding, to furnish a written statement that such employment agency, labor union, or representative will not discriminate on the basis of race, creed, color, national origin, sex, age, disability or marital status and that such union or representative will affirmatively cooperate in the implementation of this organization's obligations herein.
- d) This organization shall comply with the provisions of the Human Rights Law, all other State and Federal statutory and constitutional non-discrimination provisions. Proposer and subcontractors shall not discriminate against any employee or applicant for employment because of race, creed (religion), color, sex, national origin, sexual orientation, pregnancy or pregnancy-related conditions, gender identity, familial status, military status, age, disability, predisposing genetic characteristic, marital status or domestic violence victim status, and shall also follow the requirements of the Human Rights Law with regard to non-discrimination on the basis of prior criminal conviction and prior arrest.
- e) This organization will include the provisions of section (a) through (d) of this agreement in every subcontract in such a manner that the requirements of the subdivisions will be binding upon each subcontractor as to work in connection with the Water Board contract.

**ACCEPTED AND AGREED:**

DATE: 9 / 8 / 2023

PROPOSER (SIGNATURE):

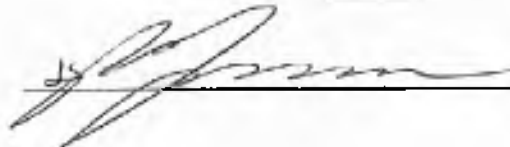

PROPOSER (NAME):

Douglas E. Zimmerman, CPA

PROPOSER (FIRM):

EFPR Group, CPAs, PLLC



APPENDIX A, FORM No. 5

STATEMENT ON SEXUAL HARASSMENT  
PURSUANT TO STATE FINANCE LAW § 139-1

By submission of this proposal, proposer(s) and each person signing on behalf of any proposer certifies, and in the case of a joint proposal each party thereto certifies as to its own organization, under penalty of perjury, that the proposer has and has implemented a written policy addressing sexual harassment prevention in the workplace and provides annual sexual harassment prevention training to all of its employees. Such policy shall, at a minimum, meet the requirements of section two hundred one-g of the labor law.

DATE: 9 / 8 / 2023

PROPOSER (SIGNATURE):

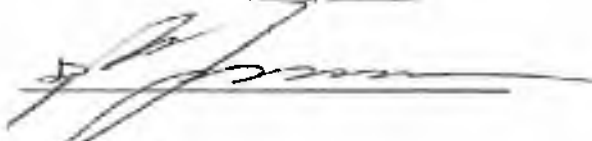

PROPOSER (NAME):

Douglas E. Zimmerman, CPA

PROPOSER (FIRM):

EFPR Group, CPAs, PLLC

STATE OF New York )

) ss.:

COUNTY OF Erie )

On the 8th day of September, 2023, before me, the undersigned, a Notary Public in and for said state, personally appeared Douglas E. Zimmerman, CPA as a representative of EFPR Group, CPAs, PLLC personally known to me or proved to me on the basis of satisfactory evidence to be the individual whose name is subscribed to the within instrument and acknowledged to me that he/she executed the same in his/her capacity, and that by his/her signature on the instrument, the entity on behalf of which the individual acted executed the instrument.

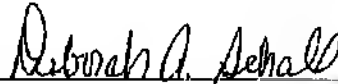

Notary Public

DEBORAH A SCHALL  
Notary Public, State of New York  
Registration No. 01SC5034524  
Qualified in Erie County  
My Commission Expires November 07, 2024

APPENDIX A, FORM No. 6

REQUEST FOR PROPOSALS
ACKNOWLEDGEMENT AND CERTIFICATION

As a duly-authorized representative of the proposer indicated below, I hereby acknowledge that by submitting a proposal in connection with

RFP No. 2023-03 Annual Audit Services
(write RFP Number and Title)

proposer has made a firm offer and agrees to be bound by its terms. Proposer has carefully read the RFP and all addenda, and in submitting this proposal acknowledges proposer understands and agrees to be bound by the requirements set forth in the RFP, except as explicitly stated on a separate sheet attached to this proposal and entitled "Exceptions." Proposer agrees and understands that the terms and conditions set forth in the RFP addenda shall be incorporated into any contract or agreement awarded in connection with this RFP, and agrees to be bound by those terms and conditions.

I recognize that all information submitted is for the express purpose of inducing the Water Board to enter a contract with the submitting business entity. I affirm, under the penalties of perjury, that to the best of my knowledge the information contained in the proposal is full, complete, and truthful.

DATE: 9 / 8 / 2023

PROPOSER (SIGNATURE):

[Handwritten signature of Douglas E. Zimmerman]

PROPOSER (NAME):

Douglas E. Zimmerman, CPA

PROPOSER (FIRM):

EFPR Group, CPAs, PLLC

STATE OF New York )
COUNTY OF Erie ) ss.:

On the 8th day of September, 2023, before me, the undersigned, a Notary Public in and for said state, personally appeared Douglas L. Zimmerman, CPA as a representative of EFPR Group, CPAs, PLLC personally known to me or proved to me on the basis of satisfactory evidence to be the individual whose name is subscribed to the within instrument and acknowledged to me that he/she executed the same in his/her capacity, and that by his/her signature on the instrument, the entity on behalf of which the individual acted executed the instrument.

[Handwritten signature of Deborah A. Schall]
Notary Public

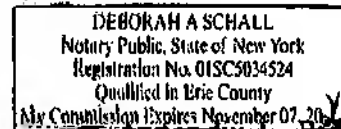

*NIAGARA FALLS WATER BOARD RESOLUTION # 2023-09-008*

**SETTLE CLAIM BY WINDSTREAM COMMUNICATIONS**

**WHEREAS**, in 2019 Niagara Falls Water Board personnel executed an agreement with Windstream Communications for data network communications services, which included monthly recurring charges over a 60-month period and liquidated damages equivalent to the full contract amount in the event of early termination; and

**WHEREAS**, in 2023 Water Board IT staff made certain network improvements and switched to a different data network communications services provider which provides improved services at a lower cost; and

**WHEREAS**, Windstream has demanded payment for its last two months of service prior to its receipt of a formal request to disconnect, plus liquidated damages equal to the remainder of the contract term, as well as late payment penalties, which altogether it claims total approximately \$115,000; and

**WHEREAS**, Windstream has advised that absent resolution of its claim it intends to commence litigation and that the total damages it seeks may be augmented by further penalties, interest, costs, or fees; and

**WHEREAS**, the Water Board has discovered certain legal defects in the original contracting process that it believes provide a defense to payment of the liquidated damages claim; and

**WHEREAS**, to resolve this matter without the expense, delay, and uncertainty of litigation, the parties have pursued efforts to resolve this matter through settlement; and

**WHEREAS**, Windstream now appears willing to accept a settlement offer that reflects the Water Board's strong legal position with respect to all or a portion of the claim because of the legal defects in the original contracting process;

\* CONTINUED ON NEXT PAGE \*

**NOW THEREFORE BE IT**

**RESOLVED**, that on behalf of the Niagara Falls Water Board, the Executive Director hereby is authorized to pay to Windstream Communications a sum of up to \$30,000 in exchange for a general release of any and all claims of any nature whatsoever which Windstream or any of its affiliates now has or may have against the Water Board, in contract, equity, tort, or of any other nature, which in any way are caused by or related to the provision of any services by Windstream to the Water Board or any of its facilities, officers, or employees.

*Water Board Personnel Responsible for Implementation of this Resolution:*

Executive Director  
General Counsel

*Water Board Budget Line or Capital Plan Item with Funds for this Resolution:*

FA.8150.0000.0446.008-Software Maintenance/Licenses

Budget Line Provided by: B. Majchrowicz

Available Funds Confirmed by: B. Majchrowicz

On September 25, 2023, the question of the adoption of the foregoing Resolution was duly put to a vote on roll call, which resulted as follows:

	<b>Yes</b>	<b>No</b>	<b>Abstain</b>	<b>Absent</b>
Board Member Asklar	[ ]	[ ]	[ ]	[ ]
Board Member Kimble	[ ]	[ ]	[ ]	[ ]
Board Member Larkin	[ ]	[ ]	[ ]	[ ]
Board Member Leffler	[ ]	[ ]	[ ]	[ ]
Chairman Forster	[ ]	[ ]	[ ]	[ ]

Signed By:

Vote Witnessed By:

\_\_\_\_\_  
Nicholas J. Forster, Chairman

\_\_\_\_\_  
Sean W. Costello, Secretary to Board

NIAGARA FALLS WATER BOARD RESOLUTION # 2023-09-009

**AWARD BID FOR 42-INCH BUTTERFLY VALVE  
FOR WWTP INTERMEDIATE PUMP**

**WHEREAS**, the Niagara Falls Water Board Wastewater Treatment Plant (“WWTP”) was placed in service in 1977 and its equipment requires periodic repair, refurbishment, or replacement in order to continue to provide reliable service; and

**WHEREAS**, a 42-inch butterfly valve serving one of the WWTP intermediate pumps has failed and must be replaced; and

**WHEREAS**, Water Board staff prepared specifications and solicited bids for a replacement valve, and have recommended award of the bid to Core & Main, Inc., the low bidder, in the amount of \$25,900;

**NOW THEREFORE BE IT**

**RESOLVED**, that the Niagara Falls Water Board hereby awards the bid for a 42-inch butterfly valve to Core & Main, Inc., for that firm’s \$25,900 bid.

*Water Board Personnel Responsible for Implementation of this Resolution:*

Executive Director  
General Counsel

*Water Board Budget Line or Capital Plan Item with Funds for this Resolution:*

CIP Item No. WWTP-11.5, Project No. 12, WWTP Intermediate Pump Upgrades  
Capital Line Provided by: D. Williamson  
Available Funds Confirmed by: B. Majchrowicz

On September 25, 2023, the question of the adoption of the foregoing Resolution was duly put to a vote on roll call, which resulted as follows:

	<b>Yes</b>	<b>No</b>	<b>Abstain</b>	<b>Absent</b>
Board Member Asklar	[ ]	[ ]	[ ]	[ ]
Board Member Kimble	[ ]	[ ]	[ ]	[ ]
Board Member Larkin	[ ]	[ ]	[ ]	[ ]
Board Member Leffler	[ ]	[ ]	[ ]	[ ]
Chairman Forster	[ ]	[ ]	[ ]	[ ]

Signed By:

Vote Witnessed By:

\_\_\_\_\_  
Nicholas J. Forster, Chairman

\_\_\_\_\_  
Sean W. Costello, Secretary to Board

# NIAGARA FALLS WATER BOARD



## **42” BUTTERFLY VALVE PROCUREMENT**

### **AWARD RECOMMENDATION MEMO**

**DATE:** 9/21/2023

The NFWB was present during the opening of bids for the above referenced procurement on Thursday, September 21, 2023 at 1:00 p.m. A total of five (5) bids were received. The NFWB recommends award of the 42” butterfly valve procurement to Core & Main, the low bidder, in the amount of \$25,900.00.

**42" BUTTERFLY VALVE PROCUREMENT**  
**BID OPENING**  
**THURSDAY SEPTEMBER 21, 2023 AT 1:00 PM**



<b>NO.</b>	<b>BIDDER</b>	<b>BID RECEIVED</b>	<b>TOTAL AMOUNT OF BID</b>
1	Valve Industries Inc	9/15/23 at 1:14 pm	\$38,990.00
2	Water Technology Resources	9/20/23 at 11:30 am	\$26,950.00
3	Ferguson Waterworks	9/20/23	\$26,713.67
4	Power-Flo Technologies Inc	9/21/23 at 11:19 am	\$28,065.00
5	Core & Main	9/21/23 at 12:15 pm	\$25,900.00